

flexium⁺

CNC SYSTEM 2024/2025

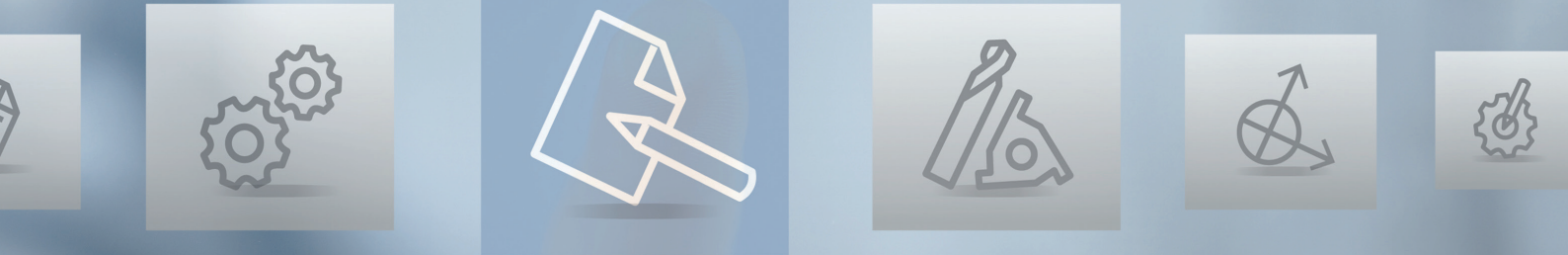

www.num.com

NUM 
CNC HighEnd Applications



Introduction	1
Flexium+ CNC System	2
Operator Panels and Industrial PC	3
Flexium+ NCK	4
NUMSafe PLC and Safe I/Os	5
NUM Motors	6
Motor / Drive Associations	7
NUMDrive X	8
NUM EtherCAT Terminals	9
Cables / Accessories	10
Flexium+ Configurations	11
General Information	12



Introduction	9
NUM, a World Player in Machine Automation	9
Flexium+ System	10
Flexium+ CNC System	13
Flexium+ System Overview	13
User / Customer Benefits	14
General Characteristics	16
Components	17
Flexium+ and Safety	27
System Functions	28
General System Composition	28
CNC Functions	30
Flexium+ PC Panels	55
Flexium+ HMI Functions	56
Flexium+ Technology HMI	58
NUMmonitor	63
Flexium Office	64
Flexium 3D	65
NUMconnect	68
Flexium Tools	70
Flexium+ PLC Functions	74
NUMSafe	76
NUMSafe PLC Functions	77
NUMDrive X Functions	80
Standard Functions	80
Optional Functions	81
Standard and Optional Safety Functions	82
Flexium+ Options Grid Summary Table	83
Basic Features and Optional Extensions	84
Machine Configuration	85
Axes, Spindle and Machining Functions	86
CNC Programming, Tools and Operation	87
PLC Functions	88
Applications	89
HMI Functions/Flexium 3D/NUMmonitor/NUMconnect/Flexium Tools	90
Option Packs	91
Option Pack Contents	92
NUMDrive X Functions	94
Operator Panels and Industrial PC	97
FS194i Operator Panels with Integrated iPC	97
Technical Characteristics	99
Outlines	100
Ordering Codes	103
FS154i Operator Panels with Integrated iPC	104
Technical Characteristics	106
Outlines	107
Ordering Codes	108



FS194L, FS153 and FS122 Operator Panels	109
FS194L Operator Panel	110
Technical Characteristics	111
Outlines	112
Ordering Codes	115
FS153 Operator Panels	116
User Interface Options	116
Technical Characteristics	117
Outlines	118
Ordering Codes	119
FS122 Operator Panel	120
User Interface Options	120
Technical Characteristics	121
Outlines	122
Ordering Codes	123
Machine Panels	124
Overview	124
MP04 Machine Panel	125
Options	126
Technical Characteristics	127
Outlines	128
Ordering Codes	129
MP05 Machine Panel	130
Outlines	131
Ordering Codes	132
MP06 Machine Panel	133
Technical Characteristics	134
Outlines	135
Ordering Codes	136
MP08 Machine Panel	137
Technical Characteristics	138
Outlines	139
Ordering Codes	140
Machine Panel Accessories	141
Industrial Box PC	143
Technical Characteristics	146
Outlines	147
Ordering Codes	149
HBA-X Portable Handwheel	150
Technical Characteristics	152
Outlines	153
Ordering Codes	154
Flexium+ NCK	155
Description	155
General Characteristics	157
Dimensions and Ordering Code	158



NUMSafe PLC and Safe I/Os	159
CTMP6900 - NUMSafe PLC	159
Technical Characteristics	160
Outlines and Ordering Code	161
CTMS1904 - NUMSafe Digital Inputs Terminal	162
Technical Characteristics	163
Outlines and Ordering Code	164
CTMS2904 - NUMSafe Digital Outputs Terminal	165
Technical Characteristics	166
Outlines and Ordering Code	167
CTMS2912 - NUMSafe Digital Outputs Terminal	168
Technical Characteristics	169
Outlines and Ordering Code	170
CTMP1960-2600 - NUMSafe Compact Controller	171
Technical Characteristics	172
Outlines and Ordering Code	173
NUM Motors	175
Overview and Product Positioning	175
BHX & SHX Servomotors	178
Characteristics	178
BHX - Ordering Codes	179
SHX - Ordering Codes	180
BPX & SPX Servomotors	181
Characteristics	181
BPX - Ordering Codes	182
SPX - Ordering Codes	183
BHX & BPX Servomotors	184
Outlines	184
SHX & SPX Servomotors	186
Outlines	186
BPH Servomotors	187
General Characteristics	187
Ordering Codes	189
BPG Servomotors	190
Characteristics	190
Ordering Codes	191
BPH & BPG Servomotors	192
Outlines	192
BHL Servomotors	193
Characteristics	193
Ordering Codes	194
Outlines	195
TMX Direct Drive Torque Motors	196
General Characteristics	196



Technical Characteristics	197
Ordering Codes	198
Outlines	199
AMS & IM Spindle Motors	200
General Characteristics	200
Technical Characteristics	201
AMS Ordering Codes	202
IM Ordering Codes	203
Outlines	204
Encoder Characteristics	206
Custom Motors	207
Motor/Drive Associations	209
Servomotors	209
Association of BHX & SHX Motors with NUMDrive X	209
Association of BPX & SPX Motors with NUMDrive X	210
Association of BPH Motors with NUMDrive X	211
Association of BHL Motors with NUMDrive X	215
Association of TMX Motors with NUMDrive X	216
Spindle Motors	217
General Description	217
Association of AMS and IM Spindle Motors with NUMDrive X	218
NUMDrive X	221
Description	221
Overview	222
General Characteristics	224
Power Supply Characteristics	225
Servo Drive Interoperability	227
Servo Drive Technical Characteristics	229
Servo Drive and Power Supply	231
Outlines Size 1	231
Outlines Size 2	232
Outlines Size 3	233
Outlines Size 4	234
Outlines Size 6	235
Power Supply Ordering Code	236
Servo Drive Ordering Code	237
NUM EtherCAT Terminals	239
General Characteristics	239
Gateways and Terminals	241
Ordering Code and Example	242
Technical Data and System Structure	243



Cables / Accessories	245
Overview	245
System Cables	250
System Connectors	252
Backup	253
NUMDrive X Connectors and Adapters	254
NUMDrive X Kits	256
Miscellaneous	259
Overview Power Supply and Accessories	260
NUMDrive X Line Filters	261
NUMDrive X Line Chokes	265
NUMDrive X Braking Resistor	270
Vibration Detector (VDR)	275
Auto-Transformer	276
Capacitor module	277
Motor Cables and Connectors	278
Flexium+ Configurations	295
Standard Configuration Flexium+ 6 and Flexium+ 8 System	295
Standard Configuration of Flexium+ 68 System	296
Multi-Panel Configuration of Flexium+	297
Flexium+ Configuration for Office PC	298
Flexium+ Configuration with Foreign Panel	299
General Information	301
Addresses / Contacts of all NUM Subsidiaries	301
Regulations	304



CNC Power Engineering - Always on the move

NUM supplies complete CNC solutions for the automation of production machines in special market segments and for customers with special requirements. The high flexibility of our systems, combined with the extensive application knowledge and expertise of our innovative engineering team, allow us to tailor solutions to exactly match the needs of our partners – machine manufacturers and other members of the machine industry.

Mission Statement:

NUM CNC solutions provide machine builders with a competitive advantage

Ever since launching its first CNC system in 1961, NUM has continued to develop and is now an independent European company with growing international activities. With our own sales and support facilities in all key regions we are able to support our machine building customers globally. We also have an extensive network of trained and certified after-sales service partners, so end-users all around the world have fast and easy access to service for machines based on NUM systems.

The Flexium CNC system is NUM's biggest success to date – in the few years since its launch it has been installed on a huge number of machines. Machine builders and end-users can feel very comfortable and secure that they are in good company when choosing NUM's Flexium platform. NUM has operated at the leading edge of technology for more than 50 years and has pioneered some major developments in the market. True to our history, with the Flexium+ system we have again set new standards.

Building on the proven concept of the Flexium system, we have added new functionality and further enhanced performance, including a new state-of-the-art security concept and programmable touch-sensitive operator panels.

Visit our website or follow us on our social media channels for the latest information on NUM CNC Applications:

 num.com

 twitter.com/NUM_CNC

 WeChat-ID: NUM_CNC_CN

 facebook.com/NUM.CNC.Applications

 linkedin.com/company/num-ag

 page.line.me/num_cnc

Accompaniment and support during the entire product lifecycle

When you select a system and a solution from NUM, you are making a long-term investment. As your partner, we participate throughout the entire process: from the conception of the idea to its execution, from on-site customer service to retrofitting years later, giving new life to quality used machines.

NUM supports you and your projects to achieve the best results for your company and its customers. The goal of our cooperation is always the same: to help you create the best-possible solution for your project.

All of our solutions are based on perfectly integrated products such as CNC systems, servo drives and motors from our own extensive range. Partnership with our customers is maintained throughout the evaluation, project and installation phases by means of training courses, support and service centres, and continues after commissioning. We make a point of advising our customers with specific know-how from our experts.

When you choose NUM, you are also choosing customer service which will continue to serve you just like new long after you have made your initial investment – even after 20 years, we still serve on-site. Our specialists can extend the life of your quality older machines with NUM Retrofits.

NUM is committed to transferring its knowledge on a regular basis. CNC knowledge and special production expertise, as well as drive and application techniques, are the subjects of the training programs taught by our specialists.

Introduction

Flexium+ System



A Compact Scalable CNC System

Flexium+ CNC is a key element of the solutions and systems of NUM.

The Flexium+ system is easily scalable and can be fully adapted to the needs of customers. Available in three configurations Flexium+ 6, Flexium+ 8 and Flexium+ 68, each equipped with specific functions and function packages, it can be tailored to the particular application.

To create an optimal CNC, just pick the platform best suited to the application and the machine, and include the appropriate options, either individually or as technology packages (turning, milling, woodworking, etc.).

Flexium+ 6

- CNC with choice of kinematic structure: milling or turning
- CNC for up to 4 axes and 1 spindle
- One CNC channel
- Interpolates up to 4 axes simultaneously

flexium+ 6

Flexium+ 8

- For CNC for up to 5 axes or 4 axes and 1 spindle.
- One channel is standard, a second is optionally available
- Interpolates up to 4 axes simultaneously
- Various options and technology packages available

flexium+ 8

Flexium+ 68

- CNC for 5 axes + spindles in standard version, up to 32 axes/spindles as an option (with a max of two analog)
- One channel is standard. 2, 4, 6 or 8 channels as an option
- Interpolates 4 axes par channel as standard, up to 9 interpolated axes per channel as an option
- Various technology packages and interpolation functions are available as options
- Possibility to create Multi-NCK configuration (option), to extend the system to more than 200 interpolated axes and 40 channels

flexium+ 68

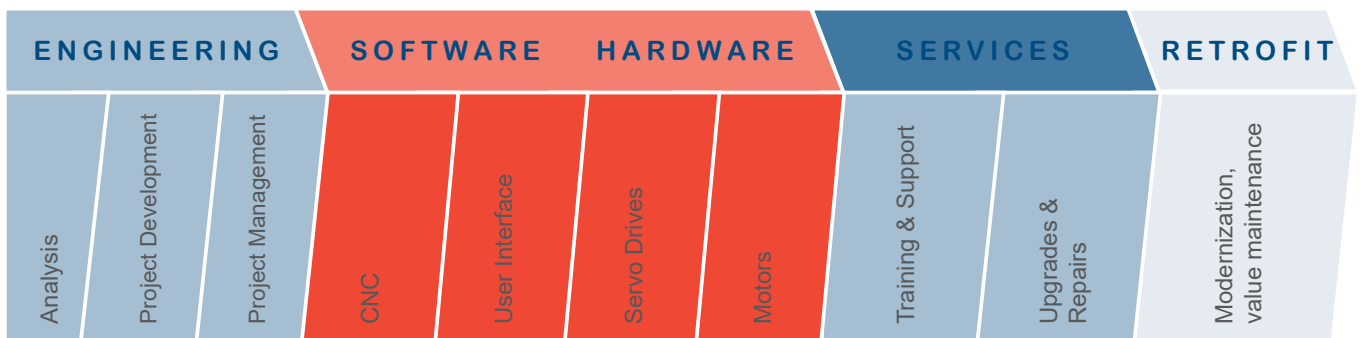



Industry 4.0 ready

1

Industry 4.0 will fundamentally change the manufacturing world as we know it today. “IIoT” (Industrial Internet of Things) and “Smart Factory” are terms that are often used in connection with Industry 4.0. The precise beginning and end of this digital transformation cannot easily be determined. The changes are coming successively, have already begun, and/or are based on already implemented solutions. Over time, the entire production logic will change: in the future, intelligent machines, storage systems, operating resources, etc., will be organized independently in real-time-capable systems along the entire value-added chain. The ultimate goal is the Smart Factory. This is characterized by flexibility, resource efficiency and ergonomic design. The integration of customers’ and business partners’ value-added processes is also part of this. Control technology plays a major role in the success of Industry 4.0. It will ultimately control the machines that produce the real products. Anticipated benefits include improved effectiveness, innovation leaps, increased information transparency and competitive advantages.

NUM’s CNC controllers have always distinguished themselves through their openness and their versatile communication possibilities. These points have been continuously enhanced from one generation of controllers to the next. The current Flexium+ CNC control system is PC-based and includes a wide range of communication options, thus satisfying the basic prerequisite for a possible Smart Factory. Fieldbuses such as EtherCAT or CAN are mostly used for horizontal integration. Vertical communication to SCADA, MES and ERP systems can be carried out via OPC, MTConnect, MQTT and other freely definable communication interfaces – which can be implemented efficiently and comprehensively using NUM’s FXServer.

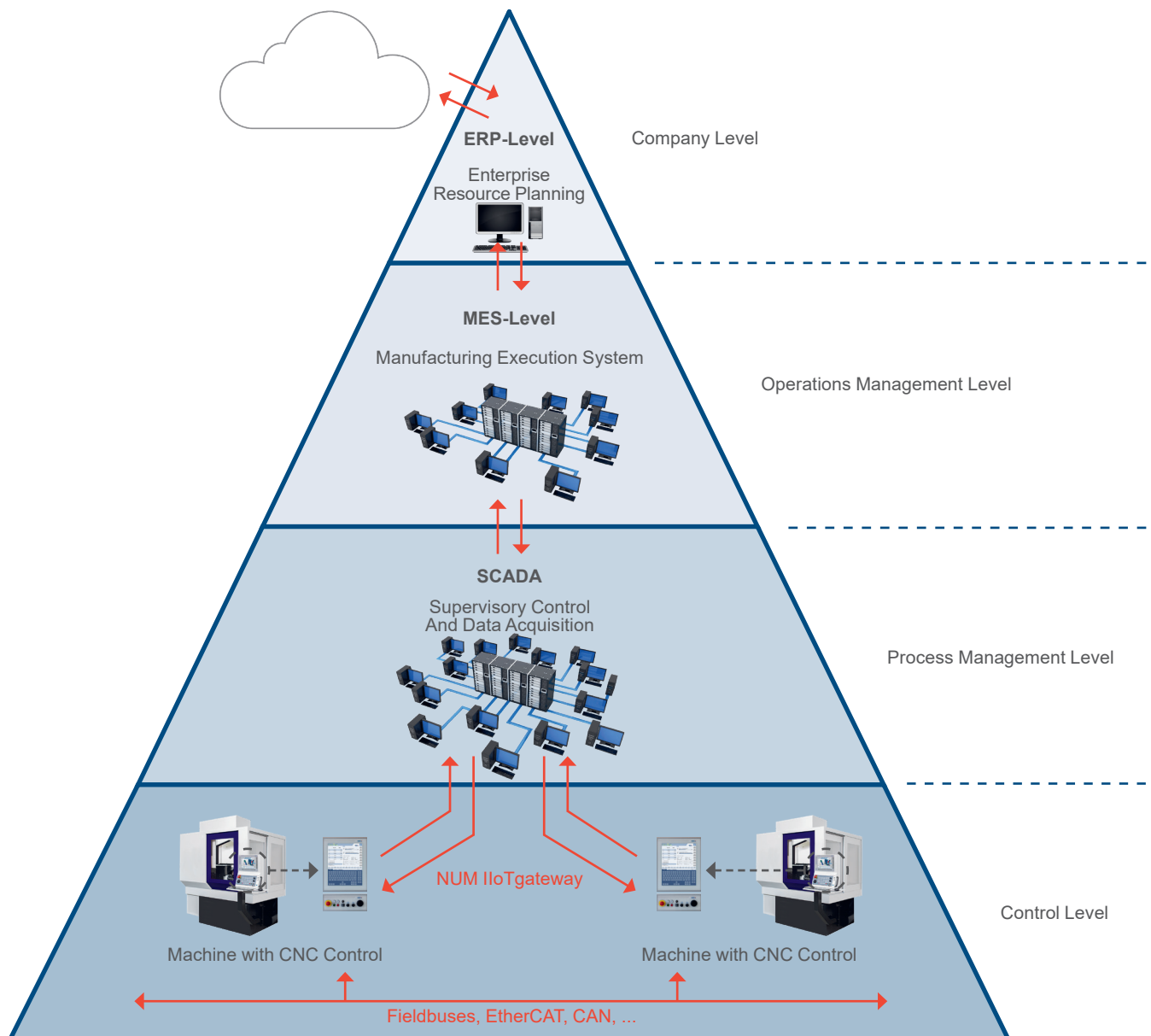



Industry 4.0 solutions

Communications variants are: NUM IIoTgateway (OPC UA, MQTT, MTConnect), OPC DA.

Open, User-Friendly and Ergonomic, Guaranteed Efficiency

NUM systems are known for their high degree of flexibility and adaptability to various configurations. This is achieved primarily by powerful functions and operator panels with dedicated Human Machine Interfaces (Flexium⁺ HMI).

CNC Functions

Flexium⁺ systems have high-level CNC functions and high performance servo drive algorithms that can be further tailored thanks to the well known dynamic operators (ISO or C) for the CNC and their new counterpart on Drive: The Drive embedded macros. All this allowing the productivity of all types of machines to be maximized.

Operator panels with an integrated industrial PC

Depending on the application, several power levels, sizes and touch functionality can be selected. Reliable and well suited to their usage, they form an ideal partnership with the Flexium⁺ NCK.

Human Machine Interface

OEMs can use or adapt the Flexium⁺ HMI, or develop their own interface using widely available off-the-shelf tools: HTML editor, Visual Basic, C#, C++, etc.

NUM Motors: Perfect for all Applications

NUM produces a comprehensive range of motors, all offering excellent volume/performance ratios and great dynamics, to suit almost any application. In combination with NUM drives, these motors provide excellent smoothness even at very low rotational speeds, and can be easily integrated into machines.

Brushless Axis Motors

Seven different ranges of NUM brushless axis motors, spanning continuous torque outputs from 0.5 to 180 Nm, make it easy to match application needs very precisely. The new BHX and BPX motors have an advantageous price/performance ratio and are available in medium and high inertia versions to suit different machine requirements, while the new SHX and SPX motors use an innovative digital interface that eliminates the need for a separate encoder cable.

Spindle Motors

The AMS and IM series of motors combine very smooth low speed operation with extremely fast and accurate positioning capabilities, making them ideal for C axis applications as well as spindle indexing. The range covers continuous power outputs from 3.7 to 55 kW.

Motorspindle®

The active parts of the motor (rotor and stator) are integrated directly in the spindle, ensuring increased machine rigidity and quieter operation. NUM has the capacity to develop special versions of these motors to suit customers' requirements.

NUMDrive X: Compact Precision and Dynamics

Based on the latest technology, NUMDrive X servo drives are the ideal partner for the powerful Flexium⁺ CNC. The drives' modular, compact design and low power consumption corresponds ideally to the needs of modern machine control systems.

One distinguishing feature of all NUMDrive X servo drives is their high power density. The drives pack an enormous amount of computing and output power into a very small module and have some of the highest power/space ratios of any units on the market. A wide range of power modules and scalable control units, available in Mono-Axis and Bi-Axes versions, enables the best technical solution to be implemented economically. For maximum precision, speed and cost-effectiveness, the performance of NUMDrive X servo drives can be tailored to suit particular machines and applications.

NUMDrive X servo drives also provide support for NUM's state-of-the-art Functional Safety Over Ethernet (FSOE) concept.



A New Platform

Flexium+ builds on the success of NUM's Flexium system to advance CNC to a new level. It combines all the power, flexibility and user-friendliness NUM's products are renowned for, with additional state of the art functionality and a completely new hardware and software platform.

2

The outstanding success of Flexium with over 10,000 applications completed in a short space of time paved the way for development of Flexium+. We took the best components, kept those elements behind the success of our previous CNCs, such as scalability, flexibility, unique CNC functions, standardized interfaces and PLC programming, then renovated and improved the complete system. Flexium+ has new and enhanced features, new panels, a new HMI, an enhanced servo bus, enhanced drives and simplified connectivity – all within a completely new safety-related architecture.

To provide optimum cost/performance ratios, Flexium+ exists in three configuration levels:

- Flexium+ 6
- Flexium+ 8
- Flexium+ 68

The compact dimensions of all components of the Flexium+ system are in line with NUM's green approach regarding limited energy requirements, smaller cabinet dimensions, reduced power dissipation, and minimal weight and packaging, while assuring the best performance.

Latest generation processors powering intelligent and evolutionary hardware ensure return on investment and a long system life, in line with NUM's philosophy.

Increased CNC functionality offers improved flexibility, scalability and accuracy. In particular, we have extended the concept of axis or spindle to allow control of up to 32 spindles per NCK unit (NCK for NC Kernel) and make spindle/ axis commutation even easier. We have also improved the internal computing resolution, increased the digital servo bus speed, and much more. The ability to link several NCKs together in a global configuration has of course been maintained, enabling, for example, the control of large transfer systems with more than 200 interpolating axes.

Thanks to enhanced algorithms, the data are processed internally with a higher accuracy. This feature, named 'Nano interpolation', provides much more precise control of travel, speed and acceleration.

The Flexium+ system encompasses the NUMDrive X digital drives controlled via up to three RJ45 ports, allowing for easily wired distributed drive sets on the machine. In addition to the digital links, two analog interfaces are provided for special requirements.

The PLC itself complies with the IEC 61131-3 standard and communicates via efficient standardized interfaces like EtherCAT for fast exchanges, as well as providing the opportunity to build a safe machine environment in compliance with the standards EN 13849-1 up to PL e and EN61800-5-2 up to SIL 3.

The human-machine interface is provided via PC panels, including a revolutionary 19" unit and companion machine panel, all running modern fully redesigned HMI software. There is a choice of machine panels and portable units, and the renowned Flexium 3D simulation package rounds out the portfolio.

The single development environment provides different access levels for machine integration, setup and maintenance.



Safety

A key distinguishing feature of Flexium+ is its new safety architecture, NUMSafe.

In short, a safe PLC is intimately integrated in the current one and, using FSOE¹ protocol, it communicates with safe inputs and safe outputs, as well as with the new NUMDrive X where the safe motion monitoring functions are implemented and executed.

NUMDrive X, featuring the new NUM-SAMX functional safety board is a key component of this solution. It maintains all of the superlative and well known characteristics of NUMDrive C – performance, scalability, modularity, reliability ...- and drives them even further.

The programming environment is provided for both “safety related” and “non safety related” logic.

Flexibility

This recognized characteristic of NUM products has now been advanced even further. With Flexium+ the notion of axis or spindle has been totally revisited. Any of the 32 devices connected can be alternatively an axis or a spindle. This makes spindle/ C axis commutation even easier but more importantly it opens the door towards new possibilities, sophisticated transfer machines being one among many.

As a direct consequence a single CNC is now able to control up to 32 spindles. Among the four spindles of each channel one will be the main on which all advanced functions (CSS, Threading ...) will be performed, the three others being declared as auxiliaries. They are controllable in speed, direction and indexing. And of course, exchanging spindles or axes between channels or declaring a new main or auxiliary spindle is just an M code away.

Productivity

Among other new features, the computing power has been more than doubled, resolution and bandwidths increased significantly, with more and faster inputs and outputs made available. Unified firmware for both Mono-axis and Bi-Axes drives makes version management even easier.

Last but not least, thanks to an innovative communication protocol that handles encoder power and data on just two wires, the encoder cable has become unnecessary and therefore was completely removed. Motors and drives can now be linked with a single cable, saving time and money.

With Flexium+, Safety now also means simplified programming, simplified wiring, simplified setup plus new functions.

¹ Fail Safe Over EtherCAT

Flexium+ CNC System

Flexium+ System Overview

Flexium+ 6, Flexium+ 8

NUM EtherCAT Terminals
NUMSafe PLC & Safe Terminals

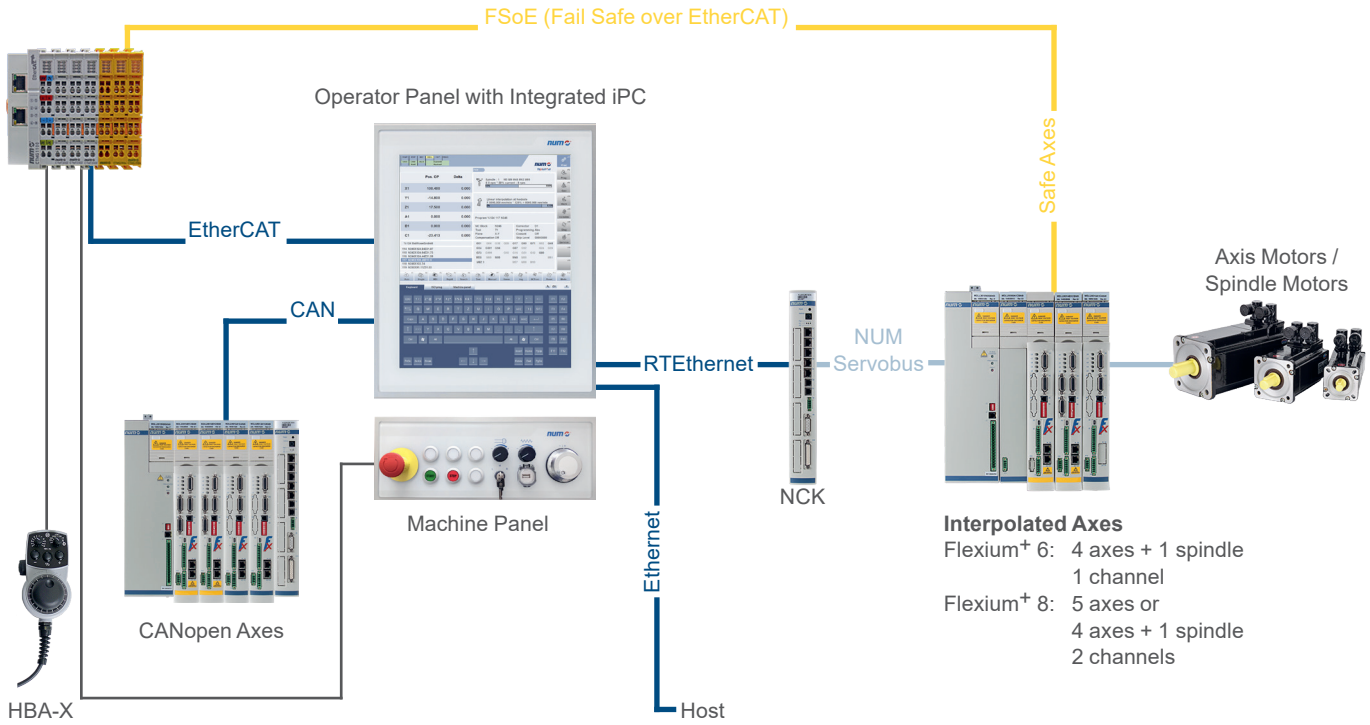

2

Flexium+ 68

NUM EtherCAT Terminals
NUMSafe PLC & Safe Terminals

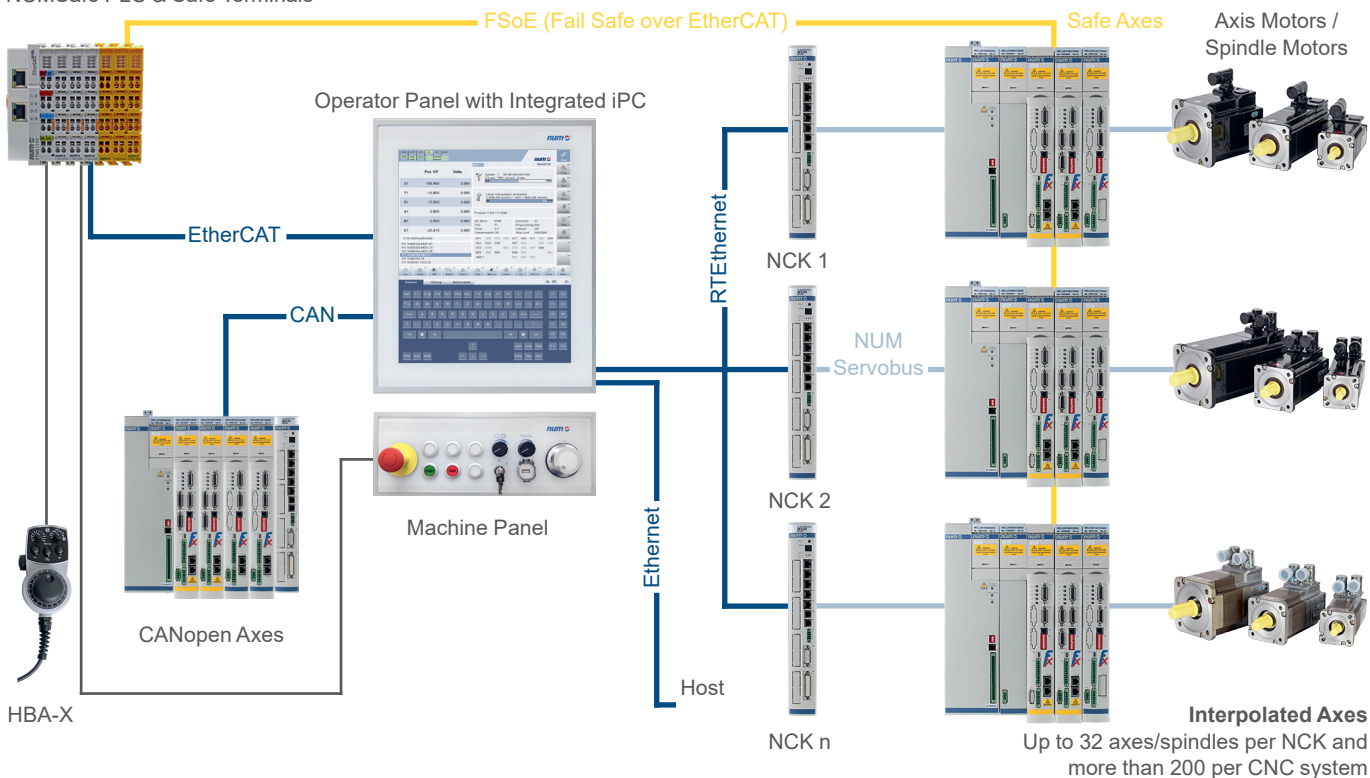



Axes Structure

One Flexium+ NCK provides up to eight ¹ channels, each able to handle up to nine axes, a main spindle and 3 auxiliary spindles. Each channel runs its own part program at its own pace, with the possibility of synchronization when necessary. Thanks to the advanced programming function, this structure offers numerous possibilities, including the ability to pass control of one or more axes from one channel to another on the fly. Moreover, the different channels can also function totally independently. This is almost like having several NCKs.

Speed and Accuracy

There is no longer any need to make compromises between extended travel and high resolution, or between fast traverse rates and high accuracy. New algorithms have been implemented to push the limits in every direction. Detailed technical characteristics are described in this catalog.

Axes Control

Enhanced acceleration algorithms allow, thanks to the increased resolution, fine tuning of the jerk value for optimal block transitions while limiting mechanical stress.

The different tools to optimize and check the servo response are integrated in the Flexium Tools development package. In close association with the digital drives, they provide monitoring of the drives' internal values, oscilloscopes to check all kinds of responses, a Ballbar ² function, Contour accuracy checking to verify machine reaction in a specific part of the machining cycle, and many other functions.

Programming

To control these new functions the part program structure has been reviewed, taking advantage of the 40 MB available.

Block numbering has been extended, and enhanced search capabilities have been provided. Direct editing facilities, in conjunction with backtrack and resume functions help interaction when necessary on long machining operations.

Emergency retract, either manually or automatically generated, is an important feature to protect people and material, should anything go wrong. More details about the programming features are given in Chapter 4.

Machining Packages

The range of specific machining packages or functions is expanded. In addition to the current Turning, Milling, Grinding (OD or surface), Gear hobbing, Shaping, etc, NUM is introducing new jet cutting functions. These include a 'tilted nozzle management' function that automatically compensates for the conical shape of the beam.

And much more:

The following pages will describe the other components of the system. It is however not possible to define in a few pages all the advantages Flexium+ could bring you. Don't hesitate to contact us - we will be happy to demonstrate our products in more detail so that you can understand why NUM, your partner, is truly a High End CNC application provider.

Process Monitoring

In the field of high-production machines the smallest incident may lead to huge economic consequences; this is why it's important to monitor the machining parameters in order to prevent down times due to a worn tool, a lubrication fault, a loss of performance or anything else.

NUMmonitor, fully integrated in Flexium+, implements such a real time process control without the need of additional sensor/hardware.

Vibration Detector (VDR)

NUM vibration detector (accelerometer) can be directly connected to NUMDrive X and it's sampled at 100 microseconds.

¹ One Channel up to 4 axes and 1 spindle for Flexium+ 6

Up to 2 channels and up to 5 axes, or 4 axes and 1 spindle, for Flexium+ 8

² Ballbar function is intended to measure and therefore correct trajectory error (sticking, quadrant transition, radius) in circular interpolation

Flexium+ CNC System

Flexium+ System Overview Components



NCK

Flexium+ NCK is the heart of a system. In a compact design compatible in size with the NUMDrive X components it packs a powerful engine, up to 40 MB of user memory, the connectivity for up to 32 digital axes or spindles and the PLC link, all delivered on standard RJ45 ports.

Additional Ethernet and clock synchronization ports for multi-NCK operation, two analog axis ports, two probing inputs as well as sixteen digital inputs, sixteen digital outputs all with direct part program access, four analog inputs and two analog outputs complete this unit.

Powered by a 24VDC 1A supply, the NCK is identical for all versions of Flexium+.

Efficient hardware is just one side of the solution; the reengineered Flexium+ firmware also provides new and innovative features. Chapter 4 describes the firmware and the options in more detail.



2

Panels FS122, FS154i, FS194i

Flexium+ PC panels (FS family) provide both the human machine interface (HMI) and the PLC function. Different versions of panels are available including a revolutionary 19" unit.

This new 19" unit (FS194i) operating panel provides a durable, modern front end for machine control. It has an IP65 degree of protection at the front, and IP20 at the rear. High-quality 4 mm hardened glass protects the front, without introducing any disturbing reflections. A narrow brushed aluminum frame with rounded edges provides complete side protection for the glass and multi-touch sensor. The FS194i presents a modern face to the world. For improved ergonomics comfort, NUM has completely revised the Flexium+ HMI panel software, in line with its design guidelines, to accommodate dual touch gestures such as 'Drag & Drop', 'Wipe', 'Zoom' and 'Rotate'. Of course, a mouse and keyboard remain available for data input and control. All HMI context levels have been adjusted to a new design for improved usability and operator convenience.

For users who want to run their HMI on a different PC, NUM offers the Box PC unit dedicated for the PLC¹ function only.



¹ The PLC function is mandatory, therefore a Flexium+ configuration must include either one FSxxxi or a Box PC



In addition to the active panels shown on the previous page, NUM offers a number of companion products for human-machine interaction.

MP04

Configurable machine panel includes 63 keys (membrane keys) with LEDs, 2 potentiometers, an emergency stop pushbutton, a three position key-switch and an optional hand-wheel. Interfaced on CANopen this panel also includes on the back 10 digital inputs and 12 digital outputs. Design fits with the FS153/FS154i family.



MP05

An ideal companion for the FS194i 19" operator panel and its virtual keyboards, the MP05 is fitted with 6 rugged buttons, two overrides, an emergency stop pushbutton, a handwheel and a USB interface.



MP06

MP06 includes 60 configurable buttons with blue LEDs, 2 Overrides potentiometers or selector for spindle speed and feed rate, 1 Handwheel (as optional), 1 Emergency stop button, 1 Three-position key switch, 3 Dedicated buttons. Design fits with the FS153 / FS154i family and it's connected with EtherCAT.

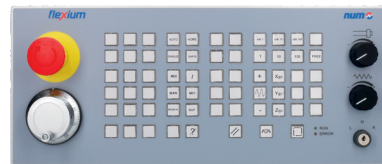

MP08

MP08 has got identical characteristics as MP06, the only differences are: smaller width dimension to fit FS122 panels and E-STOP button and handwheel are not foreseen

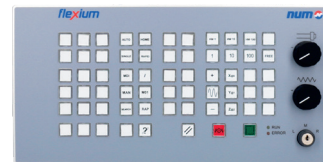

HBA Portable Handwheel

Suited for manual control of the axes, this unit combines an electronic handwheel, two selectors, three pushbuttons and a three-step dead-man's button, in an ergonomic enclosure.

Detailed characteristics of the panels are contained in Chapter 3.



Vibration Detector (VDR)

NUM vibration detector (accelerometer) can be directly connected to NUMDrive X and it's sampled at 100 microseconds; as well as for measuring accelerations it can be used in closed loop to damp machines vibrations.



Flexium+ HMI

Running on the Flexium+ panel and/or other PCs connected for multi-panel operations, Flexium+ HMI, organized in several contexts, is a very intuitive interface for interacting with the machine. Function keys located on the bottom and right side of the screen allow direct and quick access to all relevant functions and menus.

Flexibility is one distinguishing feature of the Flexium+ HMI. In the standard configuration, it already provides three 'connectors' for adding custom pages. Should the need arise for deeper customization Flexium+ HMI can be freely customized to the requirements of the user and the application, using tools such as HTML, Java, Visual Basic, Delphi, C, and C++ etc. This allows full exploitation of the machine's strong points, logically modeling the applications and, consequently, increasing the efficiency of the machining processes.

Flexium+ HMI software is a part of the Flexium Suite; it is pre-installed on the PC-panels.

Taking advantage of the 19" vertical display, Flexium+ HMI provides three virtual keyboards for:

- Machine control (virtual machine panel)
- Editing (virtual keyboard)
- ISO programming (dedicated panel)

A detailed description of the HMI technologies is given from page 58.

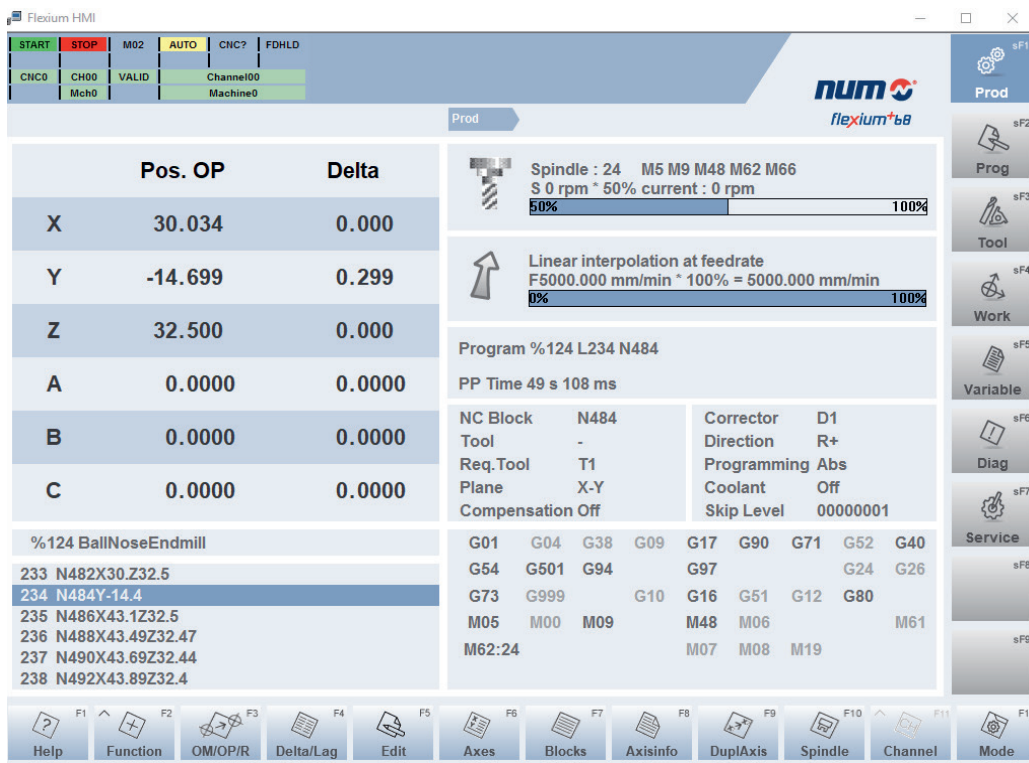



Flexium 3D

Providing fast and accurate 3D simulation, Flexium 3D is a graphical simulation software for part programs written in ISO-code (DIN 66025 with NUM extension) suited for different applications like milling, drilling and/or turning, as well as water jet and plasma cutting, etc. Other structures of machines can be created using the embedded machine editor.

It is available in two versions:

- Office version: Flexium 3D can be used as a standalone program in production planning, without a CNC, to verify and optimize manually written or CAM generated part programs with direct source reference
- Machine version: here, Flexium 3D forms an additional part of the Flexium+ HMI and is connected to the CNC. Flexium 3D can be used either to pre-simulate part program (even during processing of another) or to provide synchronous online simulation during part processing

During part program simulation you can visualize the path of the TCP (tool center point), simulate material removal from the work piece, and check for collisions between machine components, part and tool.

It exists in different configurations for milling, turning, as well as waterjet and plasma cutting:

- Turning: 3-5 axes simulation of part programs. Includes simulation of grooving, thread cutting and tapping movements and cycles
- Milling/drilling: 3-axis simulation of part programs. Includes simulation of standard milling and drilling cycles (4 to 5 axes simultaneous processing with RTCP and inclined plane are supported)
- Cutting: 2D/3D visualization of cutting contour. The configurable moving zoom window of the tool center point environment is used to illustrate local contour when comparing huge work pieces

Main features of Flexium 3D simulation:

- Wired path simulation (standard)
- Workpiece and Machine view (standard)
- Material removal
- Collision detection
- Tool Editor (standard)
- Blank Editor (standard)
- Machine Editor (standard)
- Online simulation
- SEARCH Mode (graphical supported part program Re-engagement)
- 3D-Path Editor (Contour reworking/path optimization)

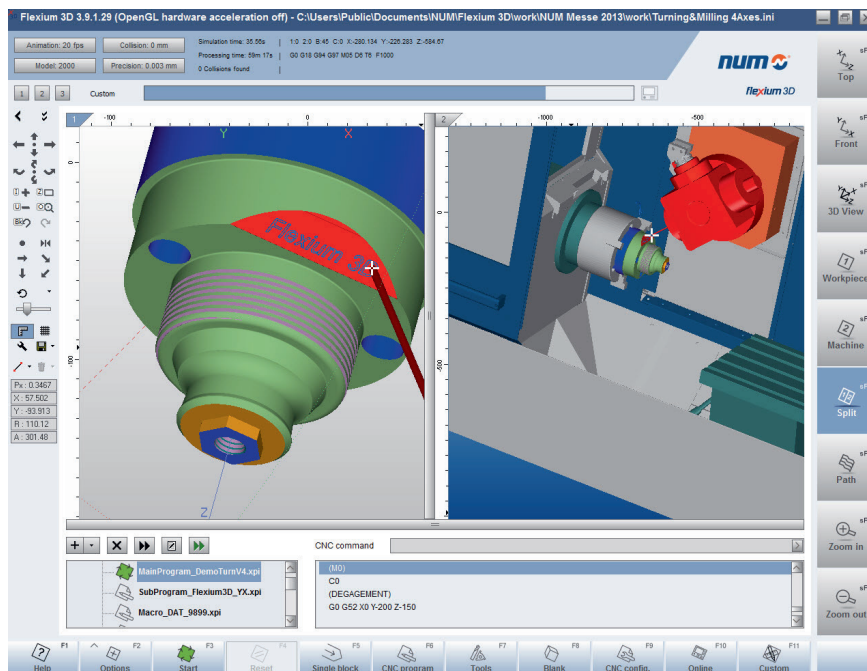

Drives

The modern design of NUMDrive X servo drives makes them the ideal counterpart to the powerful Flexium+ CNC.

One distinguishing feature of the NUMDrive X is its high power density. The servo drives offer an enormous amount of computing and drive power within a very small space and thus have one of the highest power/volume ratios available. A high degree of integration and efficiency has allowed us to achieve an extremely compact design that makes NUMDrive X one of the smallest high-end drives on the market. Thanks to a small depth and a modular width (a multiple of 50 mm) the cabinet layout is greatly simplified.

The range is characterized by a wide choice of current from a few amperes up to 282 Arms, Bi-Axes versions are available up to 2x53 Arms to enable each application to be optimized at the lowest cost. For the maximum contour precision, speeds and cost-effectiveness, the NUMDrive X servo drives can be exactly adapted to the particular machine and application.

NUMDrive X is a modular system that is optimized for multi-axes applications. Use of a common power supply unit means that only one mains connection, one line filter and one braking resistor are required per system, reducing cabling and overall costs. The system's modularity also facilitates energy exchange between different axes via the DC bus, offers the possibility of using stored energy for retraction purposes, and – in the case of regenerative power supplies – allows energy to be re-injected into the mains to reduce machine operating cost. Such system conception also leads the way for a greener approach.

NUMDrive X offers a choice of two performance levels:

- Standard-Performance (SP) drives
- High-Performance (HP) drives

Featuring high internal resolution, a short sampling time and specially developed algorithms, the HP versions are designed for sophisticated and complex applications in precision machine tools. The position control loop is closed with a very high bandwidth, achieving exceptional precision and speed at the mechanical interface of the machine (motor axis, linear motor). NUMDrive X accepts almost all measuring systems and can control a broad range of motors (servo, torque, linear, asynchronous motors) from NUM or other manufacturers. This ensures that a solution can be optimized from the technical and economic perspectives.

The HP versions of NUMDrive X also incorporate unique functionality known as DEMX (Drive Embedded Macro). This allows users to create their own real-time macro which can interact with all physical and virtual drive resources – even to the extent of manipulating the regulation algorithms. Users can design and implement filters and monitors, define test points and create pilot outputs that obey user-stipulated rules.

DEMX is an option and can be ordered using NCK option FXSO000456.

The SP versions of NUMDrive X are suited to systems and precision machine tools of medium complexity, as well as cost-sensitive applications.

Within the NUMSafe architecture, NUMDrive X provides the safe motion functionalities by means of two different modules:

- NUM-STOX is the basic module for implementing the Safe Torque Off function certified up to SIL 3 according to IEC 61508. This allows the realization of E-STOP functions category 0 and 1 according to EN60204-1
- NUM-SAMX is the extended functionality module which provides a huge number of safe motion monitoring functions. STO Safe Torque Off, SLS Safely-Limited Speed, SOS Safe Operating Stop, SS1 Safe Stop 1, SS2 Safe Stop 2, SLP Safely-Limited Position, SDI Safe Direction, SCA Safe Cam and SSM Safe Speed Monitor

Every machine builder has experienced the complexity of encoder wiring and knows that it takes time and effort to install and debug satisfactorily. NUMDrive X introduces a revolutionary innovation to overcome these issues. The drive incorporates a full digital encoder interface which uses a two-wire communication protocol. The two wires are integrated in the power cable which eliminates the need for a separate sensor cable. For more detailed characteristics on such encoders please refer to the Motors chapter.

For controlling auxiliary axes or auxiliary spindles, the NUMDrive C with CANopen interface is the most suitable solution. The CAN interface complies with a subset of the Device Profile DS402. The EDS (Electronic Data Sheet) files are available for the application of Mono-Axis and Bi-Axes versions.

Motors and Encoders

NUM produces a diverse range of brushless motors, all of which feature high power-to-weight ratios and superb dynamic performance, enabling solutions to be perfectly tailored to each application. In conjunction with NUMDrive X servo drives these motors offer high speed and power capabilities, as well as excellent stability even at very low rotational speeds. The motors are fitted with robust optical encoders of different resolution/accuracy levels to fit the requirements of the machine and the application.

As already indicated in the NUMDrive X section, the newest motor ranges SHX and SPX integrate a revolutionary encoder which on two wires only handles the encoder supply voltage, as well as high resolution position, redundant position (for safe applications), motor thermal sensor and diagnostic data. This solution eliminates the need for a separate encoder cable, so there is no longer any need to crimp and solder a large number of wires. The power cable merely contains two additional shielded wires, which are connected by screw terminals on the drive side. Aside from reduced installation time and cost, other advantages include reduced cabling costs, smaller cable carriers, lower moving masses, better reliability and electromagnetic immunity, and higher resolution control.



PLC and I/Os

The PLC

The PLC of the Flexium+ system is programmed in accordance with IEC 61131-3. Thanks to the five languages available in the programming suite, Flexium Tools, the most complex applications can be handled quickly and efficiently.

This development environment offers dedicated tools for development, commissioning and maintenance.

The complete machine project is defined graphically, using several wizards to help set up the drives, I/Os and CNC. The PLC program editors can be opened in the following languages:

- Instruction List (IL)
- Ladder (LD)
- Function Block Diagram (FBD)
- Structured Text (ST)
- Sequential Function Chart (SFC)

In order to protect their specific know-how, customers can create their own compiled libraries in addition to all standard libraries provided. The functions included in such libraries will be considered as 'black-boxes'. They will perform the functions they are intended for but none except the creator will have access to the code inside.

A Flexium+ project contains all the data to run a machine (machine structure, components, parameters, programs) which helps restore the machine to an operational condition should anything go wrong.

For enhanced security it is strongly recommended that an archive of the project is left with the machine. Different access rights can be assigned to the archive to prevent unauthorized use or tampering of its content.

PLC in a Multi-NCK System

A multi-NCK Flexium+ system for large machining cells can consist of up to 16 NCKs connected to a single PLC. This concept ensures the highest performance and makes configuration as well as operation simple and reliable.

Flexium+ CNC System

Flexium+ System Overview Components

Flexium+ I/Os

The Flexium+ I/O system is based on EtherCAT (Ethernet for Control Automation Technology). This real-time Ethernet technology is standardized by the EtherCAT Technology Group. In addition to its large acceptance and fast speed, EtherCAT opens the way to the Safe architecture NUMSafe thanks to the FSoE¹ protocol.

2

EtherCAT Protocol Process

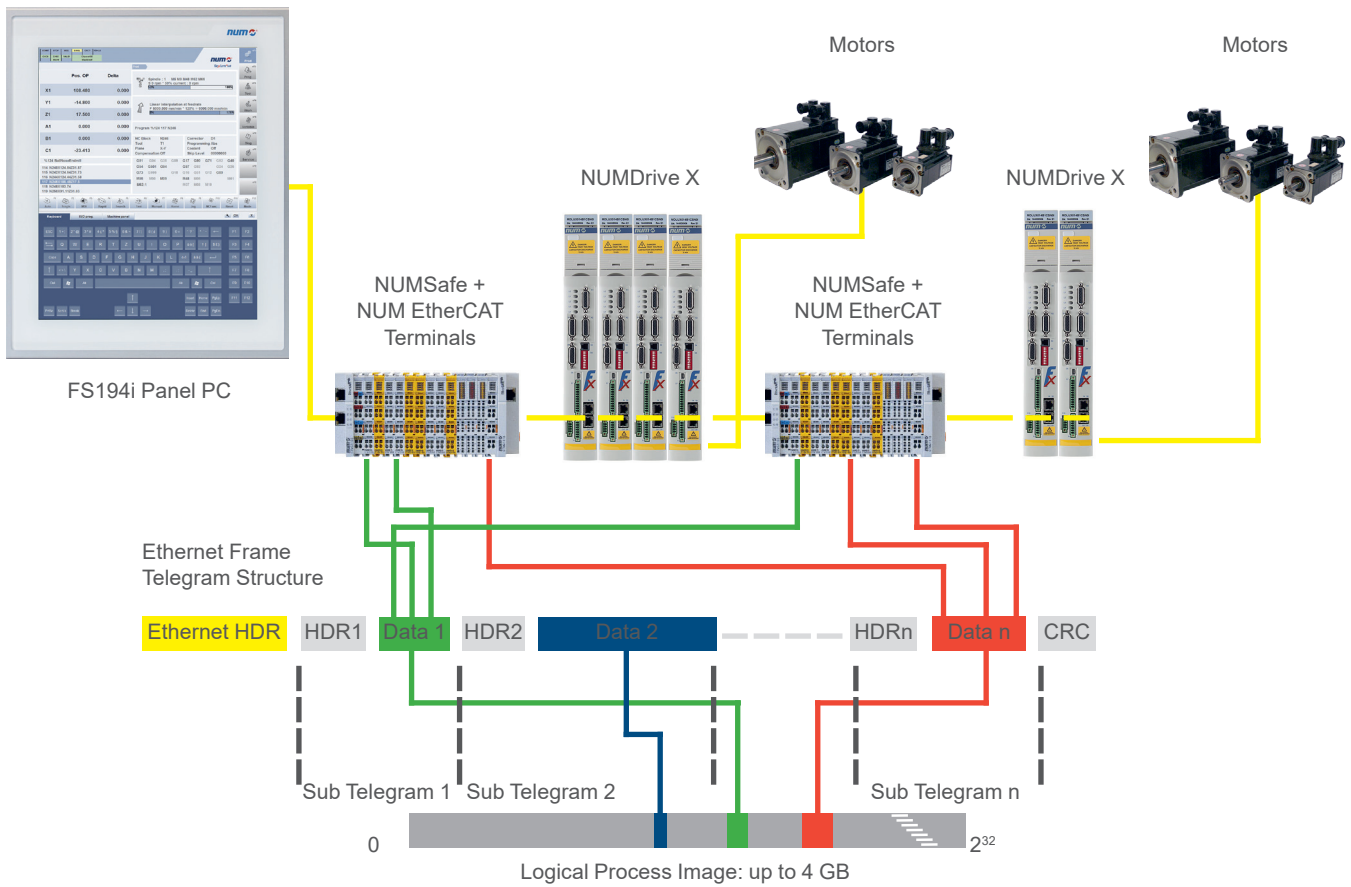

¹ FSoE: Fail Safe over Ethernet

Flexium+ I/Os

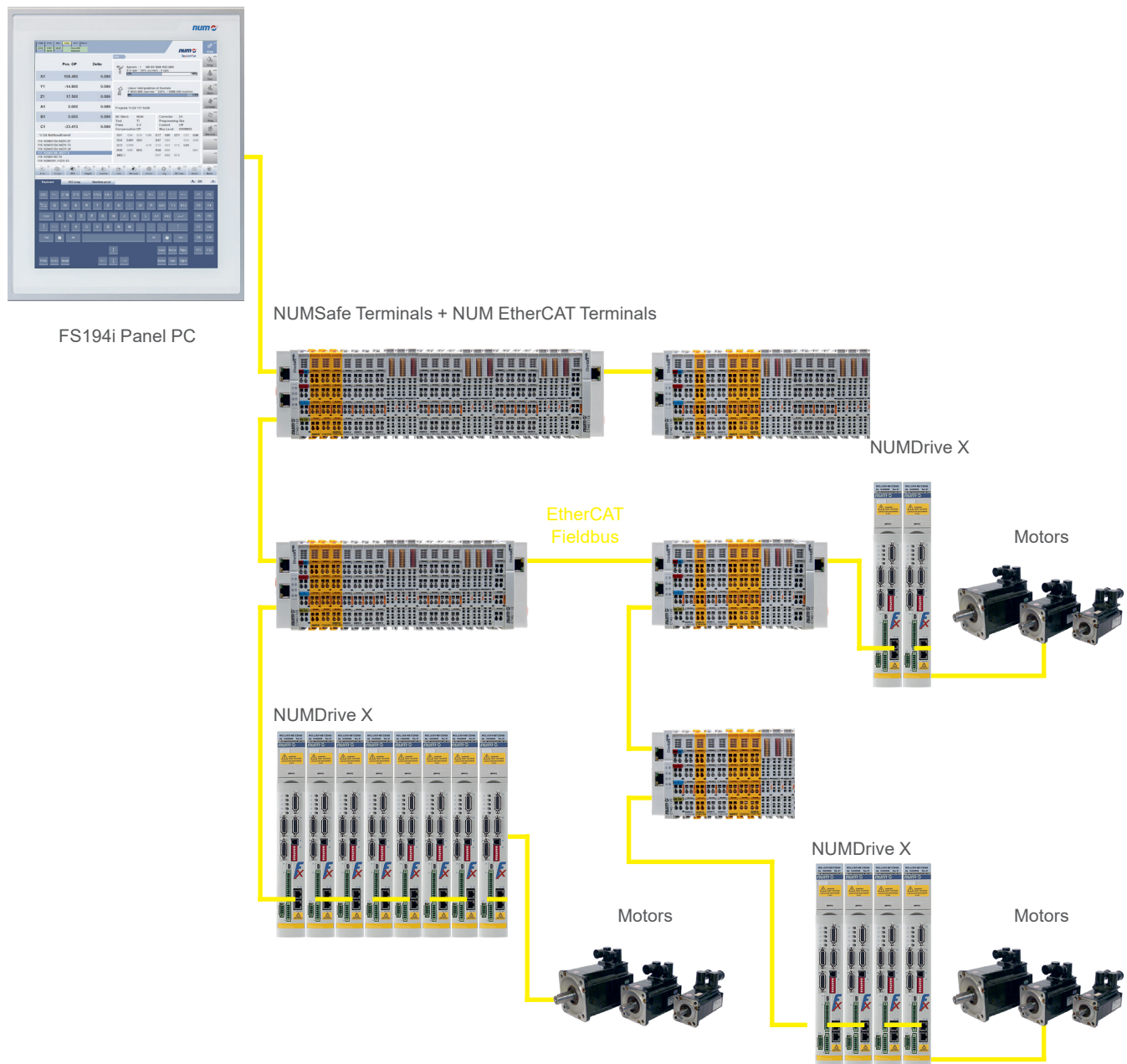

The range of I/Os consists of:

- Gateway module CTMG1100 / Gateway extension CTMG1110
- Digital and analog I/O module CTMTxxxx
- Technology modules CTMTxxxx



NUMsizer

NUMsizer supports the machine builders with the configuration, the sizing and the component selection of the complete CNC system.

The dimensioning starts with the motor selection which is determined based on the kinematic type and data. NUMsizer will propose the most suitable motors considering the kinematic data, the safety factors and the wished inertia ratio. Once motor is selected the allowed drive's associations are known too.

When all servo and spindle motors are defined, the power supply and the drives can be defined and optimized in the "Drive line-up" section.

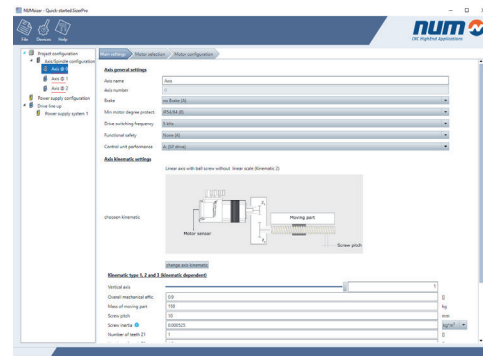

2

Flexium Tools

Flexium Tools software runs on Windows operating systems and includes all functions needed for the integration and commissioning of machines. Under a unique environment, it allows users to declare, parameterize and adjust all system components.

- Flexium+ NCKs (CNC)
- PLC structure (I/Os) and program
- Servo drives and motors
- Sensors
- EtherCAT and CANOpen gateways with a comprehensive set of I/Os and logic terminals

Easy Operation

The menu structure of Flexium Tools provides a perfect overview of the entire system. The different devices are displayed under a tree structure allowing easy access to all functions for online visualization and settings.

Project Handling

Access rights can be defined for different users. Each project consists of one single file to ensure easy handling and to prevent data losses. New equipment or versions are quickly integrated using Electronic Data Sheets (EDS) for I/O devices and Device Descriptions (DevDesc) for NUM devices. Libraries can be used in different versions and can be compiled to protect know-how. Complete projects, including libraries, devices and the source code can be archived, thus making restoration possible at any time in the future.

PLC System Programming

The PLC of the Flexium+ system is programmed in accordance with IEC 61131-3 and supports different graphical programming environments.

The logical and easily manageable development environment offers dedicated tools for development, commissioning and maintenance. The PLC program structure is displayed in a logical structure showing the different blocks and folders. The program editors can be opened in the following languages:

- Instruction List (IL)
- Ladder (LD)
- Function Block Diagram (FBD)
- Structured Text (ST)
- Sequential Function Control (SFC)

The PLC provides libraries for system functions, customer functions and its own programming functions.

Task management is very flexible with tasks that can be cyclic, event-controlled or freewheeling.

Data and variables are based on of a high level language. Data types can also be user defined.

The program can be easily structured using program building blocks, functions and function blocks with entities.

Object oriented programming is also supported and allows safe programs using objects, methods, properties, actions, interfaces and inherit functions.



Flexium NCK (CNC) Parameterizing

Dedicated editors for options, programming, memory, channels, axes (with individual windows for settings, coupling, kinematics, travels, servo system, HSC) miscellaneous hand wheels, axes calibration and more ensure easy handling and the best overview during editing.

Servo Drives Parameterizing

All servo drives of the Flexium+ System can be found and accessed easily in the menu structure of Flexium Tools. For better overview, the device structure is displayed in the way the system is set up, e.g. servo drives are listed under the controlling Flexium+ NCK.

Field Busses

Theoretically, any CANopen and/or EtherCAT compatible device can be connected to the bus using the EDS/ESI/XML file supplied with the device. NUM provides a comprehensive range of most common I/O components based on EtherCAT (Ethernet for Control Automation Technology). This real-time Ethernet technology is standardized by the EtherCAT Technology Group.

NUM also provides machine panels (like MP06), drives for auxiliary axes and other devices that, by means of dedicated windows and libraries, can be easily integrated as field bus devices.

Instruments

For easy commissioning, a huge set of instruments is available: Frequency Analyzer, Ball-Bar, Contour Accuracy Oscilloscope and others.

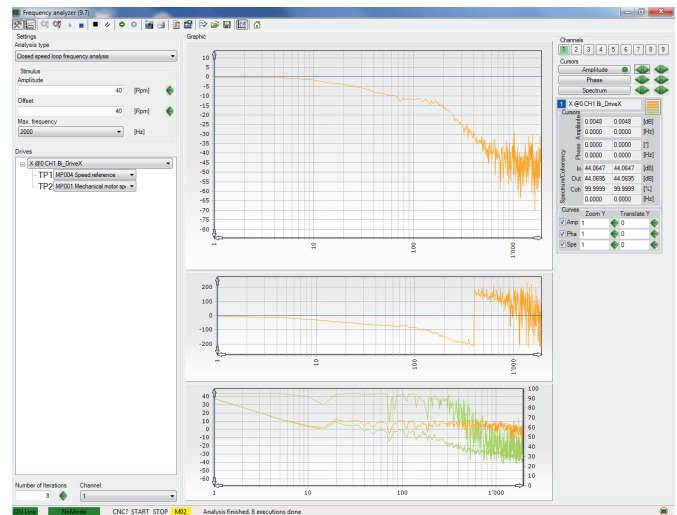

Example of a Frequency analyzer trace

Ball-Bar Function

The ball-bar function is integrated in Flexium Tools. It checks the behavior of the axes and allows adjustment of the servo drives' parameters.

Thanks to circles drawn by G02/G03 or by small segments (Tabcyls), this function generates a diagram of the radial error on the main axes or other axis pairs, which facilitates adjustment of the following parameters:

- Acceleration anticipation coefficient
- CNC reference filter time constant
- Pitch compensation.

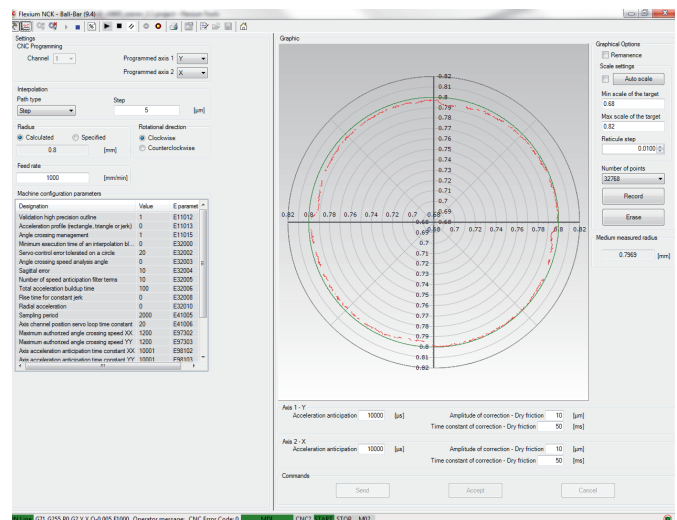

Example of a Ball-Bar trace



Flexium+ and Safety

The NUMSafe solution implements safety technology in the Flexium+ system. Offering a wide range of benefits in terms of scalability, flexibility and reduced wiring needs, NUMSafe also provides a common programming environment for all system devices.

Architectures with mixed standard and safety related signals and components are possible.

The NUMSafe offer consists of:

- NUMSafe PLC (CTMP6900, CTMP1960-2600),
- NUMSafe Digital Input modules (CTMS1904) and
- NUMSafe Digital Output modules (CTMS2904, CTMS2912)

Such components are positioned together with standard I/Os. By means of a NUM EtherCAT gateway they communicate with the automation PLC, with other EtherCAT gateways, servo drives and safety related components. The safety related motion functions are realized inside NUMDrive X by means of the NUM-SAMX board.

All safety related information is transmitted over the standard EtherCAT connection, with data reliability ensured by use of a Fail Safe over EtherCAT protocol (FSoE); wiring is reduced to a minimum, while flexibility and scalability are maximized.

The available monitoring functions, according to EN 61800-5-2, are:

- Safe Torque Off (STO)
- Safe Operating Stop (SOS)
- Safe Stop 1 (SS1)
- Safe Stop 2 (SS2)
- Safely-Limited Speed (SLS)
- Safely-Limited Position (SLP)
- Safe Direction Monitoring (SDM)
- Safe CAMs (SCA)

NUMSafe is compliant with EN 13849-1 and EN61800-5-2 up to PL e and SIL 3 respectively.



Type of Platforms

FXP1101100	Flexium+ 6
FXP1101150	Flexium+ 8
FXP2101200	Flexium+ 68

The characteristics and content of each platform are described in Basic Features and Optional Extensions, page 85.

Configuration

FXSO200060	Turning
FXSO200061	Milling

Each Flexium+ system can be configured for milling or turning. The choice is free of charge but must be stipulated at the time of order.

The main consequences of this choice are the canned cycles and the pre-selection of the interpolation plane.

The two options can be for more complex machines under the reference FXSO000581 (later in this chapter).

NCK Special Functions

FXSW282117	Multi-NCK
-------------------	------------------

The Flexium+ 68 controls up to 32 axes/spindles in up to 8 channels. Multi-NCK extends this limit and allows control over several Flexium+ NCKs connected to one single PLC. Such systems can include more than 200 axes and are typical for NUMtransfer solutions.

For the operator, the several NCKs present themselves as just one machine, making operation clear and simple.

In large systems several operating panels can be used (multi-panel configuration).

FXPA000599	NCK Digital Twin
-------------------	-------------------------

The Flexium NCK Digital Twin option allows to use the NCK with emulated drives; the NCK interoperates with the PLC like if the axes/drives are physically present. It's also possible to visualize the machine movements using Flexium 3D or ISG-virtuos¹. In case of ISG-virtuos we provide a PLC library and a dedicated XML for the EtherCAT connection.

Axes, Spindles or Measure Inputs

FXSO100006	6th axis/spindle
FXSO100008	7th + 8th axis/spindle
FXSO100012	9th up to 12th axis/spindle
FXSO100016	13th up to 16th axis/spindle
FXSO100032	17th up to 32nd axis/spindle
FXSO100373	Analog interface 1 for axis or spindle
FXSO100374	Analog interface 2 for axis or spindle

These axes are directly controlled by the CNC software using a program loaded into the user memory area, or in drip feed mode for large programs (for example a CAD/CAM). Movements are generated in an X, Y, Z Cartesian coordinate system which may be supplemented by additional U, V, W axes. These axes may be independent or grouped in carrier/carried axis pairs. Three rotary axes modulo 360 degrees, A, B and C, are associated with the main linear axes.

¹ ISG-virtuos is a product of ISG Industrielle Steuerungstechnik GmbH

Handwheels

FXSO100375	1 st Handwheel
FXSO100376	2 nd Handwheel
FXSO100377	3 rd Handwheel
FXSO100378	4 th Handwheel

A Flexium+ system can handle up to four handwheels per NCK. Handwheels are interfaced on the fieldbus or on the analog ports of the NCK (not more than 2 in this case).

Handwheels can be used for manual control of axes with a possibility of four values of increments. Validated by a specific G code, they can also be used to accelerate a move (gap-elimination) or to introduce a differential shift between axes.

Several types of handwheel devices are available in our offer: standalone, integrated in a machine panel or portable (please refer to chapter 3). The NCK has two analog outputs. They are accessible when ordering handwheel interfaces. One output is enabled per interface (max. 2).

Interpolation Capability

FXSO100335	5 th interpolated axis
FXSO100336	6 th interpolated axis
FXSO100337	7 th interpolated axis
FXSO100338	8 th interpolated axis
FXSO100339	9 th interpolated axis

According to the selected option, the system is able to move the defined number of axes in complete synchronization. The feedrate applied is defined on the linear axes; additional axes will synchronize themselves to this feedrate. As a complementary feature it is possible to define with which axes the feedrate should be computed (function G92 F...).

Multi-Channels

FXSO100392	2 nd channel
FXSO100394	3 rd + 4 th channel
FXSO100396	5 th + 6 th channel
FXSO100398	7 th + 8 th channel

In the basic version, the Flexium+ 6 controls a single channel. Flexium+ 8 can control two channels and Flexium+ 68 up to 8 channels per NCK. During commissioning, the CNC axes and spindles of a machine are dispatched among all channels available by machine parameter. Part programs can later modify this configuration if authorized to. In a multi-channel system, the machining program consists of independent programs (one per channel) denoted by a common program number, followed by the channel number. A spindle declared in a channel can be controlled by that channel or be released and controlled independently.

A multi-channel system can be configured in two ways:

- **Common Mode:** all channels simultaneously in the same mode. START, STOP and RESET commands are unique. The part programs are linked by a common number. They are executed at their own pace, which can be sequenced by synchronization points.
- **Independent Mode:** when in execution, the different channels can execute different part programs in different modes (homing is always in common mode), the START, STOP and RESET commands are independent for each channel. The part programs of each channel are independently selected and do not offer a standard synchronization function.

The first channel is always an NC channel; additional channels can be configured as:

- **NC Channels:** with all functions of the first channel
- **Auxiliary Channels:** these execute a particular part program %9998.i under control of the PLC. This is very useful for machine functionalities like tool changer, pallet changer etc...



Axes Generalities

Chapter 2 defines the axis configurations according to the system selected.

Axis and spindle performance is described below:

- Internal system resolution is 10^{-9} meter with a maximum travel of 10^3 meters for linear axes and 10^{-6} degrees with a maximum of 10^6 degrees for rotary axes (unlimited in case of modulo axis)
- The programming resolution is freely fixed from the nanometer to the 1/10 of mm for linear axes and 10^{-6} degrees to 10^{-1} degrees for rotary axes
- The maximum feedrate is linked to the sampling period and could go up to 1800 m/mm for linear axes and 5000 rpm for rotary axis
- The spindle speed ranges from 0.01 rpm to more than 100000 rpm

Axes and Spindles Features

Digital Axes Bus

DISC NT+ servobus is based on a high-speed digital bus which manages transfers between the CNC axes and spindle servo drives.

This distributed architecture ensures very fast positioning and excellent servo system stiffness, thereby optimizing contour-following and surface finish.

In addition, such architecture saves an enormous amount of time on wiring and installation.

Memory Functions

As standard, Flexium+ systems provide more than 40MB of dynamic memory for part programs and the different macros (User, Manufacturer and NUM). The permanent connection to the panel provides access to mass memory (hard drive or SSD) and optionally the LAN, offering almost unlimited storage capacity. From mass memory, the program can be stored in the dynamic memory for execution or it can be executed in drip feed mode (certain restrictions may apply).

The memory structure is as below. This part of the global memory can be divided into four functional areas:

- Area 0: Modifiable user area (NC memory)
- Area 1: Protected customer area
- Area 2: Protected OEM area
- Area 3: Area reserved for NUM

Each program or macro in the protected areas can be protected against display, editing and downloading. This safeguards proprietary information and guarantees the functional integrity of the machine.

Resident Macros

Resident macros are part programs developed by NUM, the OEM or the customer himself, and are loaded into the protected memory areas. These programs are written in standard ISO language and structured programming to facilitate understanding and modification (examples: customized canned cycles).

Editing the Macros Related to Canned Cycles: A utility included in the Flexium+ HMI is used to retrieve these cycles for editing purposes. The modified cycles can then be retransferred to any area (other than the NUM area), where they will get a higher priority.

Program Editing

Programs can be edited in the mass memory (hard disk) area at any time. Such modifications will be taken into account only after reloading the program in the NC.

It is also possible to edit the programs directly into NC memory in end of block stop. Such edits are taken into account immediately. This is very useful for example to change a feedrate or to correct a syntax error.

Axis Functions

Standard Axis Functions

Backlash Compensation

Positioning errors due to mechanical backlash on the linear and rotary axes are corrected automatically. The correction is related to the direction of movement.

Dynamic Limit Switches

The machine travels entered when setting up the machine may be dynamically limited by software. Dynamic limit switches are active in all modes.

Look-Ahead Function

The «Look-Ahead» function enables the NC to make a predictive analysis of the programmed path across several single machining blocks in advance. Thus, it has the opportunity to recognize the path characteristics and react accordingly. For optimal functioning of Look-Ahead, Flexium+ CNC prepares up to 1000 blocks per NC channel to adapt the programmed feed-rate even when there are many very small NC segments.

Acceleration and Deceleration Control

Allows progressive as well as Jerk-controlled acceleration functions to be used for smoother mechanical operation on high-speed machines.

Anti-Pitch Correction

When movement on an axis is reversed, especially at low speed, this compensation prevents spikes at quadrant changes.

Table Eccentricity Compensation (DAT3)

This function applies to the A, B or C rotary axes. Shifting the main axes compensates the offsets due to the non coaxiality between Part Origin and the axis of rotation of the table. This eccentricity can be entered:

- On the CNC panel
- By external parameter E
- By extended NCK exchange

Please note that the compensation is not continuous. It is only taken into account when the main axes are moving. A continuous correction requires a dedicated application.

Lubrication

The control informs in case the lubrication of an axis is required. Whenever an axis has traveled a predefined distance, a lubrication pulse is generated.

Free axis modulo

For rotary axes, the rollover value can be a freely definable value (not only 360°).

Time related M functions

- Timed M: The execution of an M function can be delayed or advanced by up to +/- 32000 ms with regard to the end of the block.
- Inter-sampled M: Such M functions are also delayed or advanced with respect to the end of the block, but they are provided on fast outputs (NCK X10) with an accuracy in the μs range (i.e. also between two successive real-time samples). They are used, for example, in laser cutting applications.

Tangential control (G748)

This function allows a rotary axis to maintain tangential orientation with respect to the programmed path in the working plane (2D).

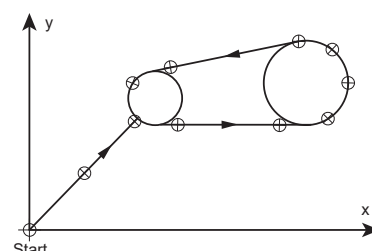



Optional Axis Functions

FXSO000266 Duplicated and synchronized axes

This function couples one or more slave axes with a master axis, either by setting machine parameters (fixed coupling) or by programming external parameters. It also ensures synchronization of the master axis with the slave axis (it does not include axis control).

The figure on the right shows a mechanical gantry axis pair (Z1 and Z2) and programmable gantry axis pair (X1 and X2, Y1 and Y2).

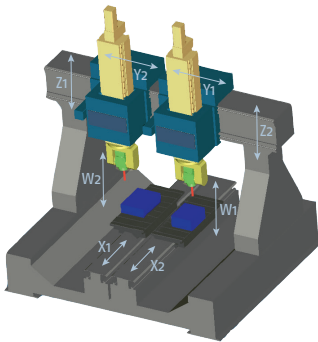

FXSO000315 Inclined or tilted axes

On a lathe or a grinding machine, the X and Z axes can be orthogonal or inclined. The axis inclination or tilt is the angle B between the X axis (the orthogonal to the Z axis) and X' axis. Coordinate conversion takes place downstream of the interpolator. In a multi-channel system, different axis inclinations can be specified for each channel. This function is particularly used on grinding machines to work simultaneously a diameter and a shoulder without the need for interpolation.

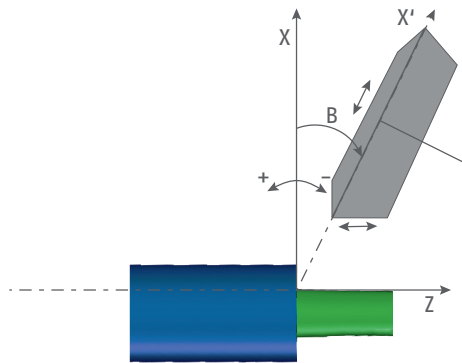

FXSO000340 Conversion Cartesian to polar/cylindric

In this turning configuration, the spindle is used as an interpolated axis with one of the CNC axes (X or Z). A resolution of at least 90,000 points per revolution is required for the measurement sensor. The spindle motor sensor used for the speed loop must be a high resolution sensor.

FXSO000402 Tool vector programming/3DWPC (G32/G34)

In five-axis machining, a widely used programming method is to program the articular coordinates of the rotary axes directly. Even though this makes the part program machine-dependent, this method has several advantages like a machine behavior easier to anticipate just by looking at the part program and a total absence of singularity (multiple attitudes for a single tool orientation).

Five-axis machining faces different challenges; part balancing is one of them. When a part is installed on a machine it might be very difficult to align it perfectly due to its weight, its structure, a previous machining or many other reasons. For these cases the NCK offers the possibility to compensate the deviations of the positioning (also angles) by appropriate correction values. The work piece remains misaligned but the NCK knows such deviations and compensate them by software. For this purpose, the Flexium HMI provides a special page where the corresponding correction values can be entered.

num flexium+b8			
Work RTCP			
Offset for Rotation around Tool Center Point			
	3D workpiece position compensation	Offset on rotary axes	
X	10.000		
Y	20.000		
Z	-50.000		
A	5.0000	0.0000	
B	6.0000	0.0000	
C	7.0000	0.0000	

The following G codes control the mentioned functions:

- G30: The part program is executed taking into account the current axis coordinates, regardless of whether the axes are linear or rotating. To take the offset into account, the part program must be edited. This is the default mode.
- G32 (Tool vector programming): In this case, the part program directly contains the tool orientation and no longer the articular coordinates of the rotary axes. This 'abstract' programming defines the orientation by the coordinates of the tool vector along the main axes. This orientation is then adjusted by the NCK according to the tilt values of the part. Finally, the articular coordinates of the rotary axes are recalculated based on this adjusted orientation.
- G34 (3DWPC): With this function, the part program continues to be written based on the articular coordinates of the rotary axes. With the knowledge of the kinematic structure, the NCK has the possibility to 'rebuild' the orientation vector of the tool. It applies the compensation to it and finally gives the adapted articular coordinates to the rotary axes. This also enables adding an inclined coordinate system with the RTCP declaration.

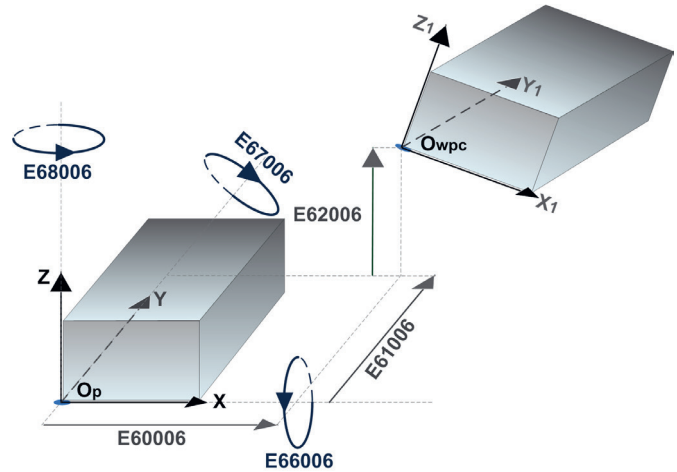

Owpc origin position shifts and Euler angles orienting the balanced coordinate system

FXSO000426 NURBS (B-Spline) interpolation

Geometric continuity of contours is a necessity for High Speed Cutting (HSC). NURBS (Non Uniform Rational B-Spline) curves, widely used in CAD and now on CNCs, are curves with poles that describe a contour in rational parametric form in order to be able to cut complex shapes with a minimum of contour error.

FXSO000518 Spline Interpolation (G06, G48, G49)

Spline interpolation is a mathematical method for smoothing curves. Spline curves are apparently continuous curves obtained by linking a series of points. With spline interpolation, the tangent is continuous and the acceleration is constant in each of the points specified on the programmed paths. Machining of a spline curve is programmed by defining:

- The points on the curve
- The sequence of execution of the curve

FXSO181706 Spline Interpolation with Curve Smoothing (G104)

Based on polynomial interpolation, this function allows the programmer to define curves of any shape in three dimensions, merely by defining the intermediate points.

FXSO000499 Smooth polynomial interpolation

Smooth polynomial interpolation allows creation of tool center paths defined by polynomials of 5 degrees or less. These paths are perfectly smooth continuous curves without segments. All the calculated points are located strictly on the curve. This type of interpolation cannot be used on modulo axes. It is incompatible with tool offsets and backtrack along the path.

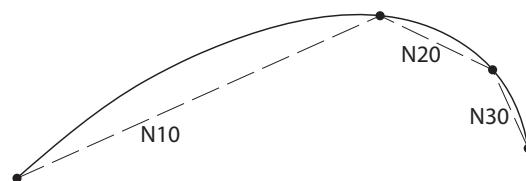

FXSO000461 Local contour rounding function (G164)

The tool path described by G1 linear segments, like programs generated by CAD/CAM, induces some tangency discontinuities among blocks. G164 (Local Contour rounding) allows to have a more fluid feed rate and to obtain a high and constant speed in corners. Based on the allowed cornering error, the algorithm adjusts the path. The deviation is defined by parameters.

This option needs the NCK function Smooth Polynomial Interpolation (FXSO000499).

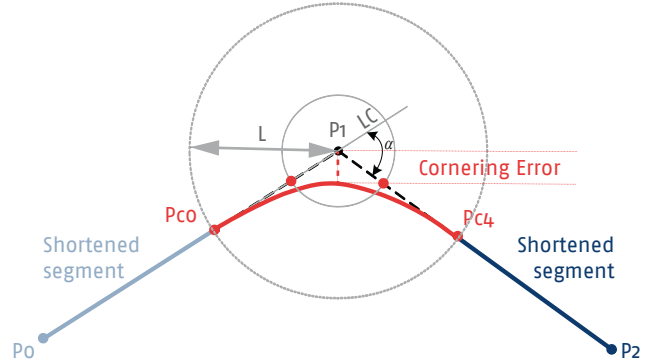

FXSO000462 Linear Feed Variation (G94 EF1)

For certain applications, a different treatment of the feed generation may be necessary, e.g. for water jet cutting. Here it is necessary to increase or reduce the feed at the corners using different strategies. This due to the beam deflection during the movement.

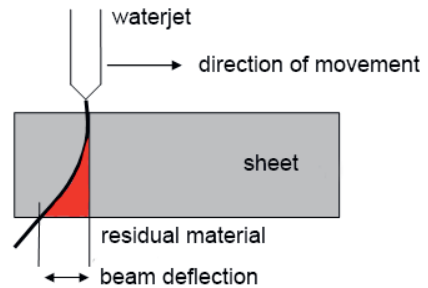

To ensure that no material is left behind, the standard feed behavior must be adjusted. The transitions between different feeds are defined as jumps. However, they are smoothed and executed with the maximum defined acceleration.

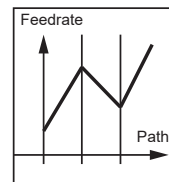
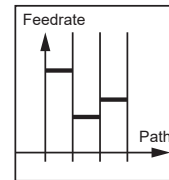

With linear feed variation, the transitions between different feeds are defined as straight lines.

FXSO000466 Technological Feed Adaptation (TFA)

This function was specifically developed for water jet cutting applications. In such applications the water jet lags behind (see picture of FXSO000462).

To prevent cutting inaccuracies the cutting speed has to be lowered before curves or corners, so that the contour error remains within a desired value. With Technological Feed Adaptation function speeds and accelerations are modulated in function of technological aspects.

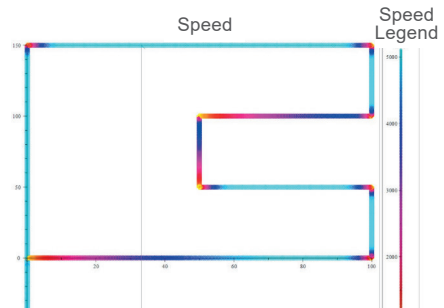

FXSO000467 Automatic Offset Compensation (AOC)

As the previous one, this function was specifically developed for water jet cutting applications; the kerf width depends on the nozzle diameter used but also depends on the cutting speed. Any change in speed requires to adjust the tool diameter compensation, this correction is automatically carried out by the function: Automatic Offset Compensation.

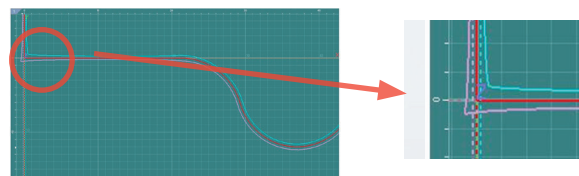

The pictures shows the feed variation.

FXSW282126 Adaptive Feed Control

The major benefits of this feature include improving the quality of ground surfaces as well as reducing the production times. This is achieved by constantly measuring and monitoring the torque of the grinding spindle as well as automatically regulating the optimal feed rate. This purely software-based “adaptive grinding” feature can be integrated in all Flexium+ -based systems without additional hardware.

Advantages at a glance:

- Shorter production times
- Smooth surfaces thanks to constant and controlled grinding pressure
- Even wear of the grinding wheel during the process
- Permanent spindle current monitoring enable collision detection as monitoring function or avoidance of consequential damage due to overload

FXSO000497 Circular interpolation by three points

This function (G23) is executed by programming:

- The start point (defined in the block preceding function G23)
- The end point and the intermediate point (defined in the block including function G23)

FXSO000514 Radial axis boring/milling function (U-axis)

This function allows interpolation of a radial axis (Z or U) as required for a boring application.

FXSO000519 Programmable precision

The smallest unit of measurement for the display of axis positions and for position programming in a part program is 1 µm as standard. This also applies to the interface between the NCK and the drives. With this option, even 0.1 µm, 10 nm and 1 nm are possible.

FXSO000699 Multi-level Electronic Gear Box (MLEGB)

The MLEGB enables you to synchronize up to five input axes or spindles, circular or linear, into a resulting axis movement. You can combine several layers and use virtual axes as results as well as inputs. Input can be fix values as well as curve tables.

It is integrated into the NC kernel and can be used in any application. The MLEGB allows for up to 25.000 rpm on an input axis.

G770 switches an axis to spindle mode so you can run it at a defined speed. With G771 you define a gear box and activate it with G775. The MLEGB also allows for Fast Gear Alignment (FGA) integration, so FGA can run, and adjust the following gear position without offsetting the MLEGB.

FXSO000463 Brake Test

To increase machine safety is often necessary to test the axis brake before to release the motor torque.

The brake test function, if correctly parametrized, checks if the axis brake can hold the axis in position; if the brake is not good enough the system keep the axis in position and torque is not disabled till a safe position is reached.

The brake test function is triggered by the PLC application; once the test is triggered, the Flexium+ system performs it autonomously. Flexium NCK informs the PLC if the test is passed.



FXSO000464 Multi-turn encoder emulation

In case of machine axes where multi-turn encoder solutions are not available, the Flexium NCK multi-turn encoder emulation function can fix the issue. The Flexium NCK memories, in real time, the number of revolutions.

The limitations are:

- in case of hard power off, less than half encoder revolution is accepted
- if the motor is moved when system is powered OFF the multi turn counts are lost

FXSO100453 Tandem function

This function includes two algorithms that are very useful for interdependent motors:

- Anti-Backlash compensation
- Torque duplication

(see section "NUMDrive X Optional Functions" page 77)



Standard Spindle Functions

Spindle indexing

This function stops the spindle in a position defined with reference to a fixed point, the angle of the end position can be programmed by M function parameter (EC for milling and C for turning configuration).

Spindle range automatic search

For spindles configured with gearing, the correct range is automatically selected by the system depending on the programmed speed.

Optional Spindle Functions

FXSO000156 Spindle synchronization

This function controls speed synchronization of two measured spindles. It is used in particular for machining operations such as parting off. Synchronization can be obtained with stopped spindles but also on the fly while the master spindle is rotating. The system will take into account the acceleration capacity of the slave spindle.

FXSO000331 Sequenced thread cutting (G31/G38)

This function synchronizes the tool axis displacement to spindle rotation. It is required in particular for the thread chasing cycle (G31) and also permits variable pitch threading. It includes the machining cycles FXSO000695 or FXSO000696 according to the selected configuration (turning or milling).

FXSO000332 Rigid Tapping

The infeed on the tool axis is synchronized to the spindle rotation. At the end of tapping, reversal is gradual and smooth. This function avoids the need of an axial floating tool holder. The rigid tapping cycle also allows the chip breaker function.



Standard Machining Functions

G20: Programming in X, Z and C polar coordinates

This function is used to program the X and Z linear axes and control a rotary C axis modulo 360 degrees. This is a standard operation.

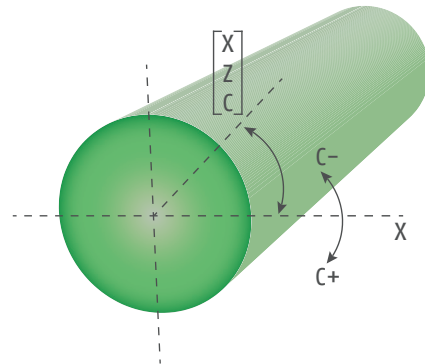

G21: Programming in X, Y and Z Cartesian coordinates

Programming is done in a fictitious Cartesian coordinate system XY perpendicular to the spindle axis. The system performs Cartesian/polar coordinate conversion (conversion of X-Y to X-C). The X and C axes are interpolated for milling in the plane perpendicular to the spindle axis. The tool is driven by an auxiliary spindle.

G21 function has been evolved to allow milling and grinding operation when the tool and the rotating workpiece are not aligned along the axis perpendicular to X.

G21 path are subjected to look ahead velocity and acceleration control. Three feed mode are possible: Constant tool centre feed, Constant contact feed and constant C axis rotation feed.

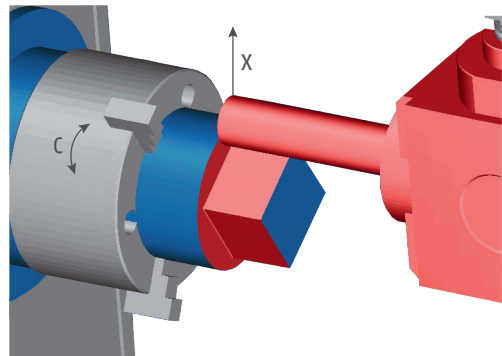

G22: Programming in X, Y and Z cylindrical coordinates

The system performs cylindrical/polar coordinate conversion (conversion of X-Y to Z-C). The C axis is interpolated for milling on the involute of the cylinder with radius X. The tool is driven by an auxiliary spindle.

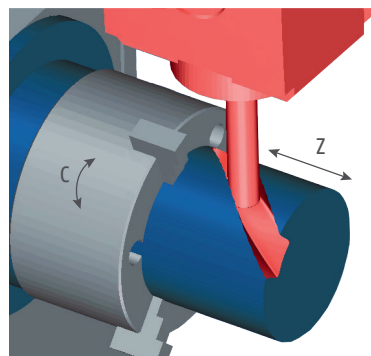

Optional Machining Functions

FXSO000154 Rotation Tool Center Point (G26 RTCP)

The RTCP function can be used with all known five-axis machine structures.

It provides automatic compensation on the main machining axis for the offsets caused by movement of the rotary axes of a five-axis machine. This compensation preserves the position of the center of a ball-end tool during interpolation.

The RTCP function is parameterized using Flexium tools. The installation program generates a macro containing a description of the machine's kinematics.

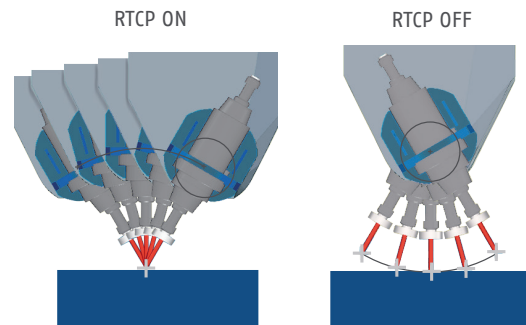

FXSO000155 High Speed Cutting (HSC)

This function practically eliminates the following error, even at high machining speeds. This is achieved by the following mechanisms:

- Total speed anticipation
- Acceleration anticipation
- Anti-pitch correction: when machining circles, the friction torque appears as dynamic backlash when reversing direction; the adjustable correction compensates for this friction torque
- Gradual acceleration with controlled jerk-rate derivative
- Accurate feed control based on upcoming changes in the machining path

This control requires evaluating the curve radius over a sufficiently long section of future path (horizon). It also requires detecting and evaluating the sharpness of corners which may exist on this segment of path. For form machining, up to 1000 blocks per channel can be pre-analyzed.

FXSW282125 NUMcoss

NUMcoss extends the classical chain of part program generation with the analysis of the trajectory and generation of polynomial interpolation data with smoother properties. NUMcoss (contour compress, smoothing and speed up) is an additional component of High Speed Cutting (HSC) and smoothing functionality in NUM CNC's (Flexium+). It is integrated into Flexium+ HMI Panel software.

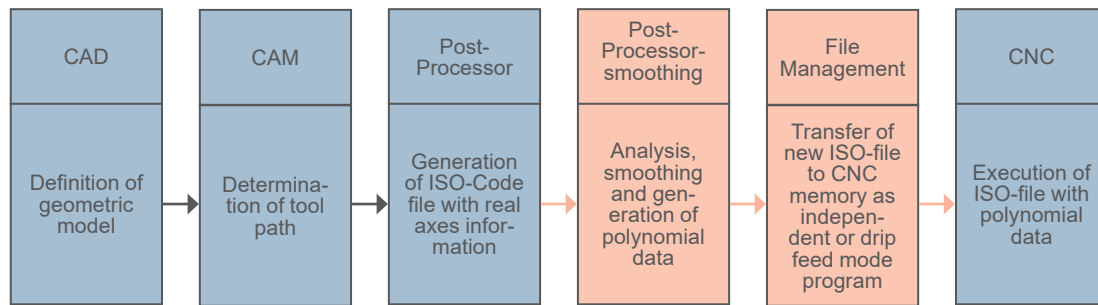

Technical Principle and Targets: With NUMcoss, the customer will get an excellent tool to speed up program execution for milling applications. Prior to data transfer to NC-kernel, NUMcoss analyses, smoothes and converts path conditions of the CAM generated ISO-programs into polynomial data. As this conversion happens on Flexium+ HMI (PC-side) the NC-kernel is not involved and its performance is free for quick interpolation and the ramp algorithm.

The main criteria in the geometric transformation of NUMcoss are modification tolerance and chord error for linear and rotary axes. That means in which dimension the given linear data (polygon path) can be modified during transition to polynomial data. Additional criteria are specific treatment of different segment lengths as well as correct filtration of spikes and geometric gaps.

Smoothing Configuration: NUMcoss provides a standard set of smoothing configuration parameters for the machine or application. These parameters can be changed in the ISO-program with specific commands. In addition to this, users can define their own sets of smoothing parameters depending on the type of machining (rough, finish and fine finish).

NUMcoss is an optional functionality for high speed applications. It can be used for analyzing and smoothing ISO-files either in drip feed mode (PPP) or for any other standard ISO-file execution.

User Benefits:

- Improved part quality (enhanced performance, less machine noise, reduced number of facets on the work piece)
- Higher execution velocity (less-data transfer, fast polynomial interpolation, and guaranteed smoother axis movements)
- Higher accuracy (pre-defined error given from CAM data generation) will be achieved

FXSO000581 Combined machine (turning + milling)

This option includes the basic milling functions plus several functions for controlling a combined machine (milling + turning):

- Axis/spindle synchronization
- Support of a radial axis (drilling)
- Cartesian/polar coordinate conversion
- Turning cycles

FXSO000695 Milling cycles

Milling Cycles (G45, G81 to G89)

The milling cycles can be called from the main machining program:

- Drilling (center drilling, counter boring, peck drilling, drilling with chip breaking), tapping
- Various types of drilling
- Other cycles: thread chasing, etc

These cycles are provided by ISO subroutines (macros) that can be edited. The standard set can be customized for the type of machine and job for which they are used.

If the option FXSO000331 is activated these cycles also include the thread chasing cycle (G31). It is also possible to create special cycles. These cycles can then be called from the main program by G functions.

Rectangular and Oblong Pocket Cycles (G45)

These cycles facilitate execution of circular, oblong, rectangular and square pocket cycles.

N.B.: Customized Cycles

It is possible to create additional cycles that are specific to an application or a machine. These cycles are then called by new G or M functions. For G functions, it is possible to create programs %10100 to %10255 and call them by functions G100 to G255 respectively.

For unassigned M functions, a machine parameter, 'subroutine call by M function' is used to call a program number defined at installation when the M function is detected in the part program.

FXSO000696 Turning cycles

Turning Cycles (G63 to G66, G81 to G87, G89)

These cycles can be called from the main machining program:

- Groove roughing, face-turn roughing, plunging
- Drilling (center drilling, counter boring, peck drilling, drilling with chip breaking), tapping
- Drilling cycles

These cycles can be edited and special cycles can be created. They are called by G functions (see Customized Cycles above).

FXSO100538 Polygon-cutting cycles

This turning function is used for cutting flats or polygonal shapes on the surfaces of parts of revolution. The cutting technique is based on synchronization of a rotary axis with a spindle rotating in the same direction with a programmed speed ratio.

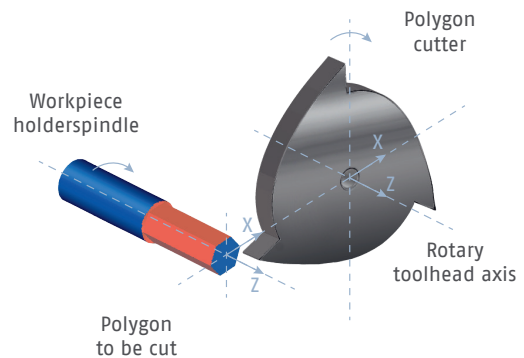



FXSO000700 Trochoidal Milling Cycle (G725)

A Trochoidal/cycloidal motion is the curve that describes a point on the circumference of a circle when the circle moves along a straight line.

Trochoidal milling is a specific strategy for milling that uses new CAM programming systems and control cycles to achieve consistent tool engagement, higher material removal, and a consistent average chip thickness. As a result, optimum and effective machining processes are guaranteed.

This feature is called Trochoidal Milling Cycle and can be started with G725 in NUM ISO programming with different cycle parameters including feed definition.

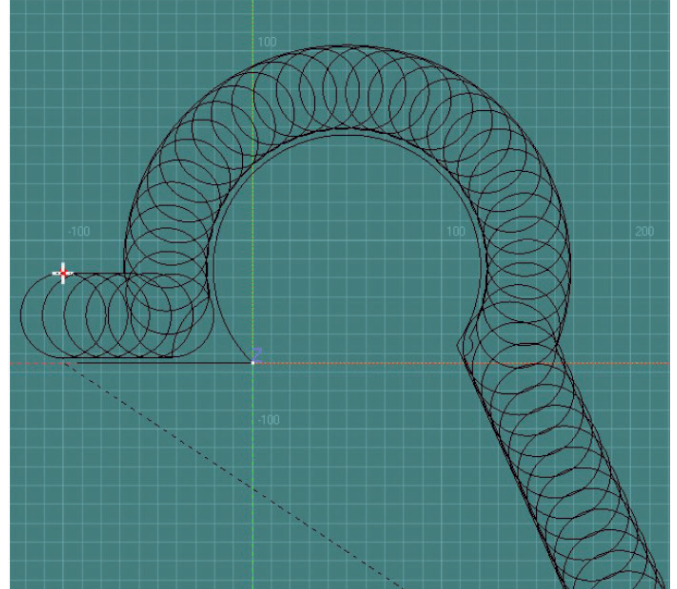

FXSO000701 Engraving Cycle (G730)

The G730 cycle is used to engrave characters from a string of text by interpolating the axes in the machine. The symbols that are available are the uppercase and lowercase letters (A-Z and a-z), number from 0-9 and some special characters.

It is possible to write text in a straight line, with an inclination, or along the circumference of a circle with radius R. Each letter can also be rotated by an additional angle (inclined character).

This engraving cycle allows the end user to write some text (such as a ID, serial numbers, piece coding or date and time) on the work piece without using a CAD/CAM system or any other software tool.

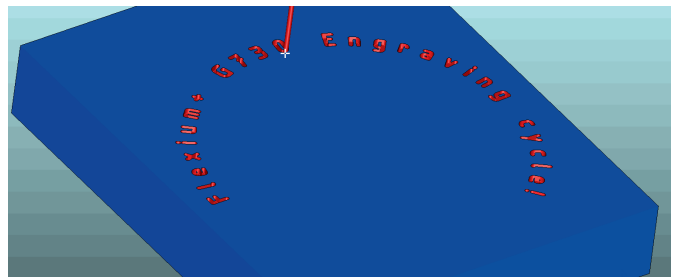

FXSO000404 Tilted Nozzle Management (TNM)

This feature is mostly used for jet cutting applications. It is intended to take into account the fact that the cutting head is not always perpendicular to the interpolation plane by recalculating the angles and continuously repositioning the nozzle to keep the same inclination.

The nozzle orientation vector, that will finely reposition the head, is defined by two curves figuring the jet center path at the top of the part and at the bottom of it.

- At the top, the trajectory is created from the program trajectory like for the usual G41/G42 compensation
- At the bottom the trajectory is offset by the value of the jet radius + the tilting effect (nozzle angle along the part height)

Depending on the type of crossing it may add an additional connecting block between two programmed blocks. It also performs the anti-collision monitoring at top and at bottom.

Due to the orientation the jet section is no more a circle but an ellipse. The system will automatically adjust the value to compensate correctly. This function requires the option FXSO000154 Rotation Tool Center Point (G26 RTCP).

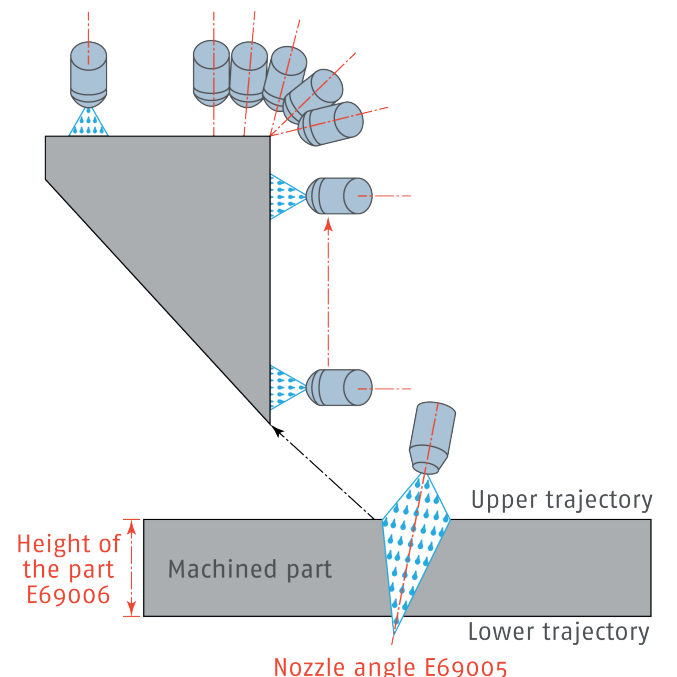



FXSO000914 Inclined plane machining

The inclined-plane machining function manages many different machine head structures and simplifies programming of the machining operations.

Rotation and translation are combined to define a three-axis reference system with any orientation, used by the CNC to control the machine.

All the standard functions can still be used in this condition:

- L and R tool offsets,
- Canned cycles as well as control of speed and feed,
- Acceleration and travel

The inclined reference system is defined as follows:

- UVW / XYZ translations
- ABC rotations around each of the XYZ axes

All five-axis machine structures are supported with their offsets:

- Machine-head with two rotary axes with or without angle
- Machine-head with one rotary axis and turntable with one rotary axis
- Turntable with two rotary axes

The inclined plane machining function is parameterized using Flexium tools. The installation program generates a macro containing a description of the machine's kinematics.

Workpiece positioning compensation

When a workpiece is positioned on a machine it might be very difficult to align it perfectly due to its weight, its structure, a previous machining operation or for some other reason. A shift parallel to the main axes is not a problem and merely requires a work offset to adjust it. However, a tilt can become quite tricky because it implies compensation of the tool orientation. One common solution, after identifying the offsets and tilt angles, is to reprocess the program and generate a new one to take the misalignment into account, but this obviously takes some time. NUM offers some cycles and parameters to align the workpiece or compensate easily without requiring the regeneration of the part program, and the operator can double check their settings using a dedicated page inside the HMI. The advantage is that the part program will not be changed because the CNC will compensate for the misalignment automatically.

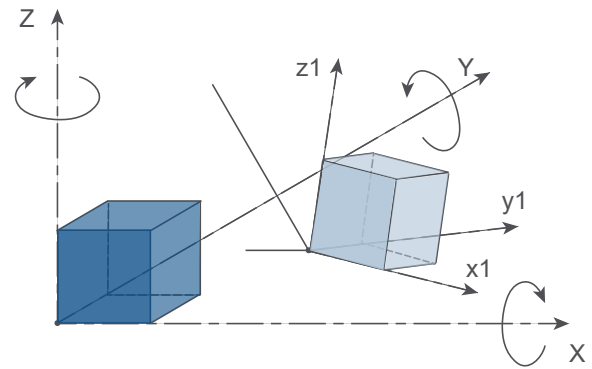

Tool vector programming

With the workpiece positioning compensation, we introduced the concept of tool vector. This approach can be used also for a generation of part program independently from the machine. The part program written with a tool vector orientation can run on machines with different kinematics. In fact, a CNC that knows the machine's kinematic can compute the angles of physical rotary axes and the linked linear transformation. The advantage is that a part program can be generated without knowledge of the machine's kinematic where it will be executed.

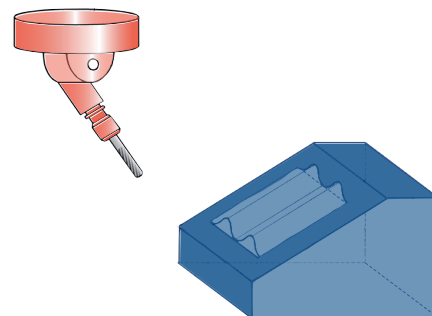



FXSO000681 NUMgrind GC Cycles

The cylindrical grinding package includes OD/ID grinding cycles for 2-axis (X/Z) horizontal or vertical grinding machines and inclined axis capability. The dressing station can be table-mounted or rear-positioned to accommodate a range of machines. Standard forms or profiled wheels can be dressed with single point, double point or roller dresser.

The packages include the following features:

Grinding Cycles:

- OD/ID Plunge / Multi-plunge
- OD/ID Plunge with inclined Axes (Angular Plunge)
- OD/ID Oscillating Plunge / Multi-plunge
- OD/ID Cylindrical Traverse
- OD/ID Profile Grinding
- OD/ID Conical Traverse
- OD/ID Oscillating Shoulder / Shoulder Plunge
- OD/ID Shoulder Traverse
- OD/ID Shoulder with fillet

Auxiliary Grinding Functions:

- Wheel speed calculation
- Z position probe
- Manual measurement
- Taper correction
- Fixed or roller dresser wheel dressing
- Fixed dresser wheel shaping
- Part, Dresser and Z Position Probe Setup Routines
- Full cycle support for In-Process Gauging and Gap Elimination (AE Sensor)

FXSO000682 NUMgrind Cylindrical + Non-Circular Grinding Cycles

The non-circular grinding package is designed for a 3-axis (X/Z/C) horizontal or vertical grinding machine. The package includes all the functionalities of FXSO000681 (NUMgrind GC cycles) and the possibility to grind geometries in the Cartesian or polar coordinate system.

The NCG cycles have a wide range of parameterization possibilities. Furthermore, an error compensation cycle can be used to compensate for form errors, which can occur due to workpiece deflection, for example, without any problems.

Additional cycles, which are included in the package, are as follows:

- OD/ID Non-Circular Grinding
- Error Compensation
- Axis-Spindle Switching

FXSO000595 Fast Gear Alignment (FGA)

Gear Alignment allows for the exact positioning of pre-cut gears to a previously recorded master gear position. It enables processing gears without manual intervention. FGA is ideal for automated mass production of gears.

Using a sensor (hall, inductive, etc.), you record rising and falling flanks of a master gear manually aligned with the tool.

Recorded values will then be used to subsequently automatically align following gears to exactly the same position as the master gear with regard to the tool. Second stage hobbing or skiving, TWG, or profile grinding can start instantly.

The interface is a simple call of G184 code for the master gear and G186 for the following gear without any parameter. The FGA will take care of the positioning of the following gear.



FXSO000690 NUMgear Hobbing Cycles

The NUMgear Hobbing cycles provide single indexing and continuous hobbing. Hobbing requires the MLEGB (FXSO000699). FGA (FXSO000595) is optional.

The cycles provide the following functions:

- Single indexing - milling
- Continuous Cutting
- Axial Cycles
- Crowning with optional offset or straight sections
- Up to 3 taper sections that can be combined with crowning
- Selectable dwell after radial and axial infeed
- Radial Cycles
- Worm gear with optional tangential feed
- Single indexing
- Diagonal Cycles (combine axial and radial)
- Cut helical, spur or spline gears
- Taper root splines
- Up to five gears on one work piece using different hobs on one axis
- Tailstock control
- Coolant control

FXSO000691 NUMgear TWG Cycles

NUMgear TWG (Threaded Wheel Grinding) cycles provide both grinding cycle and dressing cycle. Both cycles can run independently. Both cycles require the NUM MLEGB (FXSO000699). FGA (FXSO000595) is optional but recommended. TWG Dressing is based on a full-form dressing wheel.

The cycles provide the following functions:

- Grinding
- Free form flank shape point interpolation
- Automatic grinding wheel shift
- Two way grinding
- Pass input automated and manually
- Shifting options per cut
- Dressing after a predefined number of grinding cycles
- Dressing
- Roughing and finishing
- Feeds and passes
- Tailstock control
- Coolant control

FXSO000692 NUMgear Shaping Cycles

The NUMgear Shaping cycles provide for internal and external gear shaping. Shaping requires the MLEGB (FXSO000699). FGA (FXSO000595) is optional.

The MLEGB controls both the shaping movement and the turning of tool and gear.

The cycles provide the following functions:

- Tailstock control
- Coolant control



Programming Functions

Standard Programming Functions

ISO Code:

Flexium+ complies with the ISO standard and includes specific extensions for advanced functions.

The general programming format is as below:

%.....	
N.....	Sequence number
G...	Preparatory functions
XYZ+8.8	Axis movements
UVW+8.8	Auxiliary axis movements
ABC+5.8	Rotary axis movements
IJK+5.8	Circle center coordinates
EA3.3	Taper angle
EB5.8	Fillet or chamfer
EC3.8	Indexed spindle axis
ED3.8	Programmed angular offset
R8.8	Circle radius
F....	Feed rate
M...	Miscellaneous functions
S.....	Spindle speed
T.....	Tool number
D...	Tool offset
L...	Program variable
E.....	External parameter
H....	Subroutine number
/	Block skip

Datum Shifts

Regardless of the programming mode selected, the system always processes the dimensions with respect to a zero point or origin. The system provides 5 sets of DAT1 (part origin setting) combined with up to 99 DAT2 (program origin setting).

Measurement Origin (OM)

The measurement origin is a suitable point defined on each axis which sets the absolute measurement origin or zero point. The coordinates of this point can be entered or modified in special machine parameters.

Part Origin (Op)

The part or workpiece origin is independent of the measurement system. It is defined with respect to a suitable setting point on the workpiece. The part origin is specified with respect to the measurement origin by datum shift DAT1.

Program Origin (OP)

The program origin defines the origin of the program coordinate system. It is independent of the measurement system and is specified with respect to the part origin by datum shift DAT2.

Flexium+ provides 4 Part origins and up to 99 program origins selectable by G code.

Subroutines

Subroutines are special programs called by the main program. They are created by the OEM, by NUM (in the case of macros) or by the user to simplify and optimize the main program.

Example: Pattern repetition in several locations.

Subroutines can be called by the specific function G77. They can also be called by the PLC or by an M function.

Parametric Programming

Parametric programming simplifies the writing of programs and the creation of identical families.

There are two kinds of parameters: L variables (Float) and E parameters.

L variables and external E parameters can be assigned to all the program addresses. Operations available on parameters:

- Addition, subtraction, multiplication, division, square root, truncation, sine, cosine, arc tangent
- Conditional and unconditional branches (>, <, =), logic
- AND and OR

Profile Geometric Programming

This special ISO programming language allows the rapid development of parts with a complex geometry consisting of a sequence of linear and circular geometric elements.

Main Functions:

- Insertion of fillets and chamfers
- Multiple line definitions
- Multiple circle definitions
- Ability to implicitly declare from one to three consecutive elements and have the system compute the intersection or tangent points

Customized Cycles

It is possible to create additional cycles that are specific to an application or a machine. These cycles are then called by new G or M functions. For G functions, it is possible to create programs %10100 to 10255 and call them by functions G100 to G255 respectively. For unassigned M functions, a machine parameter, 'subroutine call by M function' is used to call a program number defined at installation when the M function is detected in the part program.

Inch/Metric

Internally, the system works in metric units. Display and programming default units for dimensions can be selected by a machine parameter when integrating the system. This default can be overwritten by the HMI, using function G70 for programming in inches, and function G71 for programming in metric units.



Optional Programming Functions

FXSO000506 Scaling factor (G74)

The scaling factor can be entered from the keyboard or via an E parameter to modify the dimensions of the part to be machined. It is expressed in thousandths of the programmed dimensions. The variations are between 0.001 and 9.999.

FXSO000507 Angular program offset (ED)

Function ED is assigned a value which defines an angular rotation with respect to the program origin. The angular offset affects the axes programmed in the blocks following the function. Example of application: machining along a circular pattern.

FXSO000511 File handling in NC memory (G76)

This function is used to save the values of several parameters in a file included in a subroutine or a block sequence of the main program. The nominated file lists the L variables and E parameters that will be updated with current settings.

Syntax:

- G76 Transfers the current settings of L variables and E parameters to the specified program
- H Specifies the program to which the settings are to be transferred
- N..N.. Specifies the block sequence to which the settings are to be transferred

FXSO000520 On the fly measurement / probing (G10)

The NCK provides two probing inputs. Application of a signal to either one will cause the actual positions of the axes to be stored in registers, and if programmed to do so, can trigger an interruption of the move.

FXSO000535 Structured and symbolic programming

Structured programming based on symbolic variables makes programs easier to read and understand. Symbolic variables (1 to 32 characters) can be created and assigned to all ISO functions and used in parametric expressions. In addition a stack is available to preserve such variables as well as the L variables.

FXSO000536 Building a profile table

This high-level programming function is used to create a table and to store into it the data concerning a contour. The data in the table can then be accessed in any order, used by structured programming, and optionally modified and then executed. Typical applications are contour transformation (particular tool compensation), backwards execution etc...

The contour table has the capability to store additional fields for general purpose, feed rate, spindle speed etc.

FXSO000465 Advanced contour offset (C.OFF)

Advanced contour offset is a function which processes user defined contour in order to offset them by a given value. The contours can be programmed in both Cartesian and polar coordinates. The contour offset can be constant or variable along the contour path. In this mode, initial offset and final offset are programmed and the final offset is reached at contour end.

Offset contour can be joined together to allow spiral approach to the final path dimension. This function could also be used for pocket milling. The contours can be either internal or external to the workpiece. During contour offset function the contour curves are analyzed to allow constant contact tool-piece feed rate. C.OFF can also shift a contour on the laying plane and compensate the misalignment between workpiece center and tool axis (for polar contour only).



FXSO000500 Early Block Change (G777 EBC)

Early Block Change EBC means a faster machining cycle, as the NCK can begin the execution of the next block before the previous has been finished. EBC also provides a very fast signal exchange between PLC and part program, which allows the PLC to send and receive information about the program execution using 32 dedicated input bits and 32 dedicated output bits.

The block change may occur under several conditions:

1. Immediately, the two blocks are therefore executed simultaneously
2. After a certain distance has been traversed
3. When the residual distance (Delta or To Go distance) is lower than a value
4. When the PLC sets a certain signal
5. When the block is normally ended (standard way)

Furthermore the NCK communicates to the PLC when certain conditions in the program execution have been reached, allowing the PLC to start auxiliary operations without the need to program M functions and thus without stopping any axes.

All these features are easily programmed with a single G function and a few parameters. For example, "Z100 G777 Q1 X40 P24 I25" tells the control to move the Z axes to the position Z100 mm, when 40 mm have been travelled the PLC output bit 24 will be set, and when the PLC input bit 25 is set then the execution of the next block will start, even before the Z axis has arrived at its final position.

Simple example in the chart:

```
G777+ Q1 D80  
G1 X100  
G1 Y100 Z100
```



FXSO000250 Dynamic operators

This powerful language opens the real-time kernel of the CNC.

It uses simple operations to perform real-time computations which can act directly on the axis position references and on discrete or analog inputs and outputs. This tool, which also supports exchanges with the PLC program, offers the possibility of immediate correction according to the environment. The dynamic operators operate with high priority at the real-time clock frequency of the CNC and do not penalize the functions managed by the CNC software. They are very useful in application programs, especially for operations on the servo systems and other high-speed tasks.

FXSO000249 Dynamic operators in C

Uses an identical principle to the standard dynamic operators (see item below). The option of using C language brings additional power and the opportunity to access much more data. The C compiler is not included. It will be indicated on request.

Tool Functions

Standard Tool Functions

Tool Axis Selection (G16)

Tool Axis Orientation Function G16 with one of the mandatory arguments (P, Q, and R) followed by a plus or minus sign defines the tool axis orientation.

The tool axis can be oriented in six different positions on machines with an interchangeable tool-head. This allows the tool axis to be defined independently of the interpolation plane.

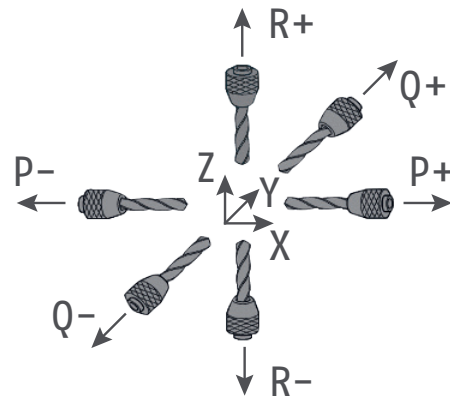

Tools Offset

Turning Tools: The tool length offset is assigned to the tool axis orientation defined by G16. The programmed tool paths are corrected by a value equal to the tool length X and Z defined in the D offset selected.

Tool Radius Offset: the programmed tool paths are corrected by a value equal to the tool insert radius based on the tool nose orientation defined by codes C0 to C8 defined in the D offset selected.

- G41 offsets the contour to the left with respect to the direction of movement
- G42 offsets the contour to the right with respect to the direction of movement

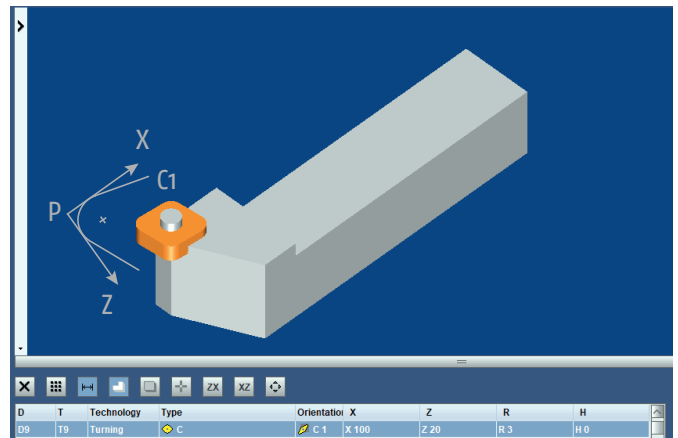

Milling Tools

The tool length offset is assigned to the tool axis orientation defined by G16. The programmed tool paths are corrected by a value equal to the tool length L defined in the D offset selected.

Tool Radius Offset: the programmed tool paths are corrected by a value equal to the tool radius defined in the D offset selected.

- G41 offsets the contour to the left with respect to the direction of movement
- G42 offsets the contour to the right with respect to the direction of movement

Tool Wear Compensation

It is possible to compensate for slight variations of the tool dimensions. These compensations are taken into account immediately when below a certain amount. They can be entered automatically by the PLC or by the operator (in such case they are incremental).



Optional Tool Management Functions

FXSO000401 Extension to 255 offsets

The basic system includes 32 tool offsets for turning systems, and 99 for milling.

The D address followed by a number selects the tool offset.
The tool dimensions are stored in tables and validated according to the programmed axes.

FXSO000400 3D tool radius correction (G29)

With 3D tool radius correction, the tool axis is parallel to one of the axes of the basic three-axis reference system defined by the tool axis orientation function (G16). Each programmed point is associated with a vector normal to the surface to be machined, defined by its P, Q and R components.

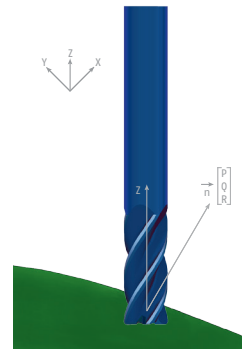

FXSO000411 3D tool radius correction in RTCP (G43)

With 5-axis tool offset, the tool axis can be inclined on machines equipped with a double twist tool head.

Each programmed point is associated with a vector normal to the surface to be machined, defined by components P, Q and R, plus a tool orientation vector defined by components I, J and K, where applicable, which define the angles of the twist head.

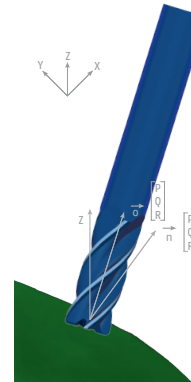

FXSW282119 Tool management

Build around a database (local or shared between several Flexium+) this system includes dedicated NC and PLC functions as well as specific HMI pages. It can handle a very large number of tools (limitation linked to the available disk size) of different types (turning, milling, boring) and sizes (standard, medium or large). Each tool having up to 18 cuts according to the configuration. Of course duplo tools (identical cutting characteristics) are offered as well. It can also handle several tool magazines (disk, chain or rack) each in random or fixed place management. New and advanced tool characteristics are offered as maximum speed and maximum feed rate. The tool life is monitored either in time, wear amount, or number of operations with possibility of pre-warning when the limits are approached.

In association with the power of the PLC such system permits to build quickly and easily, simple to complex, tool management systems with limited engineering requirements. Flexium 3D will be connected to this tool database as well in a future development.

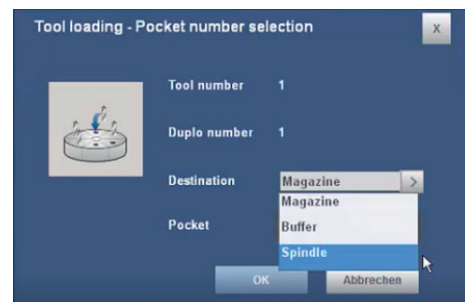



Optional Machine Operations

FXSO000082 **N/M Auto**

When enabled by the PLC, this function allows the operator to manually control up to five axes while the other axes remain under control of the part program.

The axes which can be controlled manually are selected and deselected by external parameters in the part program.

Any command in the program for movement on these axes is then ignored. Only the manual controls are active.

If this function is used to mode the milling head axes then RCTP will probably be required.

FXSO000505 **Emergency retract (G75)**

On receipt of a signal sent to the PLC the current block is immediately interrupted and a jump to a previously specified program sequence is executed.

This feature is widely used on grinding and gear cutting machines.

Emergency retract can also be triggered automatically in some predefined conditions (refer to commissioning manual).

FXSO000523 **Backtrack along stored path**

This function is used to backtrack the axes and then return it to the point where the program was interrupted all being made under the operator's control.

On a feed stop command, the operator enables the backtrack-along-path command. As long as the command is active, the axes are moved back along the path at the feed rate programmed in the previously executed and memorized (up to 100). This function is operative in automatic, single-step and dry run modes.

When the operator enables the return command to resume, the trajectory is then executed forward up to the point of interruption, where the initial mode will be restored.

The program can be resumed beyond of the backtrack point.

Tool offsets and wear offsets less than 0.1 mm can be applied during backtrack and return.

The automatic axis recall function can be used in intervention mode. In this case, the points on the manual backtrack path are stored (maximum 10 points) and restored in the same order in the axis recall phase at the traverse, up to a programmable distance from the restart point.



Standard Compensations

Axis Calibration

This function corrects the axis position according to the defects of the screw, rack or scale of the same axis.

Interaxes Calibration

This function corrects the position reference of an axis via the position of another axis. The data are entered in a table. A typical use of this function is to compensate for the weight of the “ram head” on a milling machine.

Optional Compensations

FXSO000460 VECComp rotary axes

On a rotary axis, even a little imperfection can have a large influence due to the lever effect. To compensate the resulting errors at the Tool Center Point without a complex measurement campaign, VECComp Rotary is the right solution.

A rotary axis is defined by its average line of rotation that, in respect to the machine referential, presents the following characteristics:

- Off centering
- Axial position error
- Two tilt angles

Example is shown for a C axis.

Each of these errors is defined by the normalization (Suffix C defines the axis):

- EX0C: Position error in the X direction
- EY0C: Position error in the Y direction
- EA0C: Perpendicularity error relative to Y
- EB0C: Perpendicularity relative to X
- EC0C: Zero position error

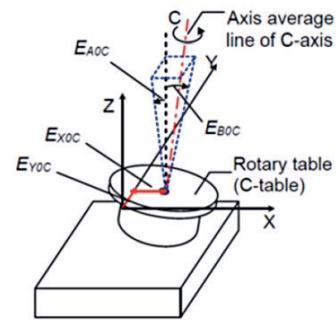

After measurement of the rotary axis imperfections, the errors will be entered in a table of data with the help of a worksheet macro. The error compensation is performed after defining a model of the machine structure which is considered as a succession of elements. Considering this model and based on the above values of errors, VECComp Rotary will calculate in real time the compensation to apply in order to position the Tool Center Point with the maximum accuracy.

The activation of the compensation only consists into the programming of a G code and no more than three parameters at the maximum. The possibilities of a temporary suspend and resume of the compensation is provided.

VECComp rotary is compatible with the following five axes machines:

- Tilting turntable or trunnion machines (A)
- Swivel head and rotary table combined (B)
- Dual twist head machines (C)

Conventional 4 axes machine with either one turntable or one swiveling axis head are compatible as well.

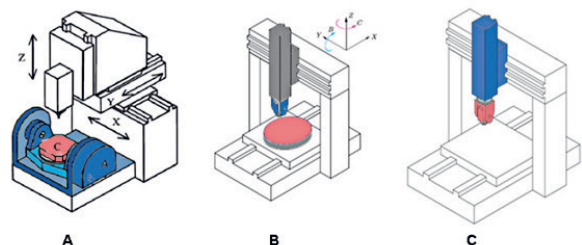

FXSO000458 VECComp 3-/4-axes Machines

FXSO000459 VECComp 5-axes Machines

VECComp system is a function of Flexium+ NCK, based on geometric error compensation, to enhance machine tool volumetric accuracy and work piece precision. The errors of machine tools come from imperfect geometry and dimensions of machine components, axis alignment errors, error motions of linear or rotary axes, thermal deformation, dynamic and structural deformation of the machine under load.

VECComp system is a real time application of spatial error compensation based on kinematic error modeling.

For each machine having a serial kinematic structure, the error model is originally designed as a superposition of error motions of linear or rotary mechanical components starting from the work piece side to the cutting tool center. A library of kinematic error machine models is managed by the embedded VECComp, including from 3 axes configurations up to 5 axes machine in gantry configuration.

The purpose of such control is minimizing the spatial error of tool center position at an arbitrary point in the work piece. Each geometric error has been previously measured by a laser interferometer or by other metrology optical devices.



Optional Measuring Functions

FXSO100590 Probing cycles for turning

These cycles are designed for use in adjustment and measurement applications generated manually or automatically. They include the following functions:

- Probe calibration
- Tool presetting
- Workpiece measurement and offset adjustment
- Determination and restoring of DAT2 on the linear X and Z axes

All these cycles can be edited.

FXSO100591 Probing cycles for milling

The available cycles are designed for use in setting and measurement applications generated manually or automatically. They include the following functions:

- Probe calibration
- Tool presetting (L, R)
- Determination and restoring of DAT2 on the X, Y and Z axes (workpiece location)
- DAT2 on the A, B and C rotary axes (workpiece alignment on a table)
- Determination and restoring of DAT3 (off-centering of a workpiece on a table)

All these cycles can be edited.

The usage of the probing cycles is supported by easy to use conversational pages integrated in the Flexium+ HMI. The operator is graphically guided in the definition of the technological data needed for the measurement, such as the feed rate and probing speed, followed by preparatory data such as the approach and starting positions, and input and output data specific to the selected cycle.

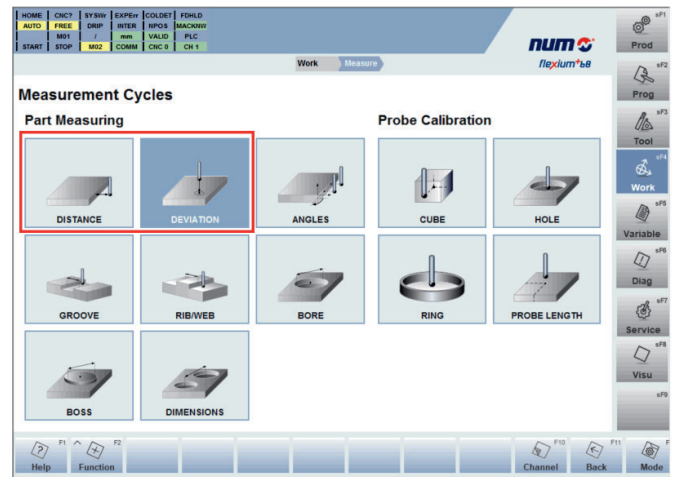

Once a measurement cycle has been initiated by the operator, all probe positioning can be handled automatically by the CNC. The probe stylus is fully protected against collision with the part in the working environment, with any error being signalled to the CNC system and causing an immediate stop. The software includes full management of the RTCP (Rotation Tool Center Point) function, to handle inclined coordinates inside the measurement circle.

The operator selects the type of measurement out of 17 different work piece measurement cycles and 6 probe calibration cycles.

FXSO000153 Kinematic measurement cycle

The Kinematic measurement cycle (G248) is intended to measure and then compensate the geometric deviations of a rotary head. It can be used during machine commissioning or after a machine crash.

It requires:

- a digital touch probe
- a calibrated ball

The principle is to execute different measurements taken at strategic points chosen by the macro itself. The results of those measures are then computed by the macro in order to fine tune the head dimensions. The head description parameters are automatically optimized.

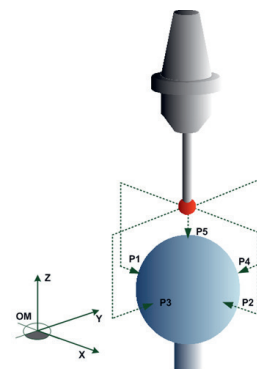

Flexium+ Panels

The FS154i and FS194i Panels are generally used to run the PLC function and the Flexium+ HMI. In a Flexium+ system one and only one PLC is mandatory, regardless of the number of NCKs. For this reason different versions are available:

- PC panel with PLC function (RTS) and screen
- PC panel without PLC function but with screen (for multi panels systems)
- Panel without PC altogether (terminal for an external PC)

The PC panels are available with a 15" LCD or with a 19" LCD (portrait and landscape).

For the product characteristics, versions, part number and dimensions, see chapter 3.

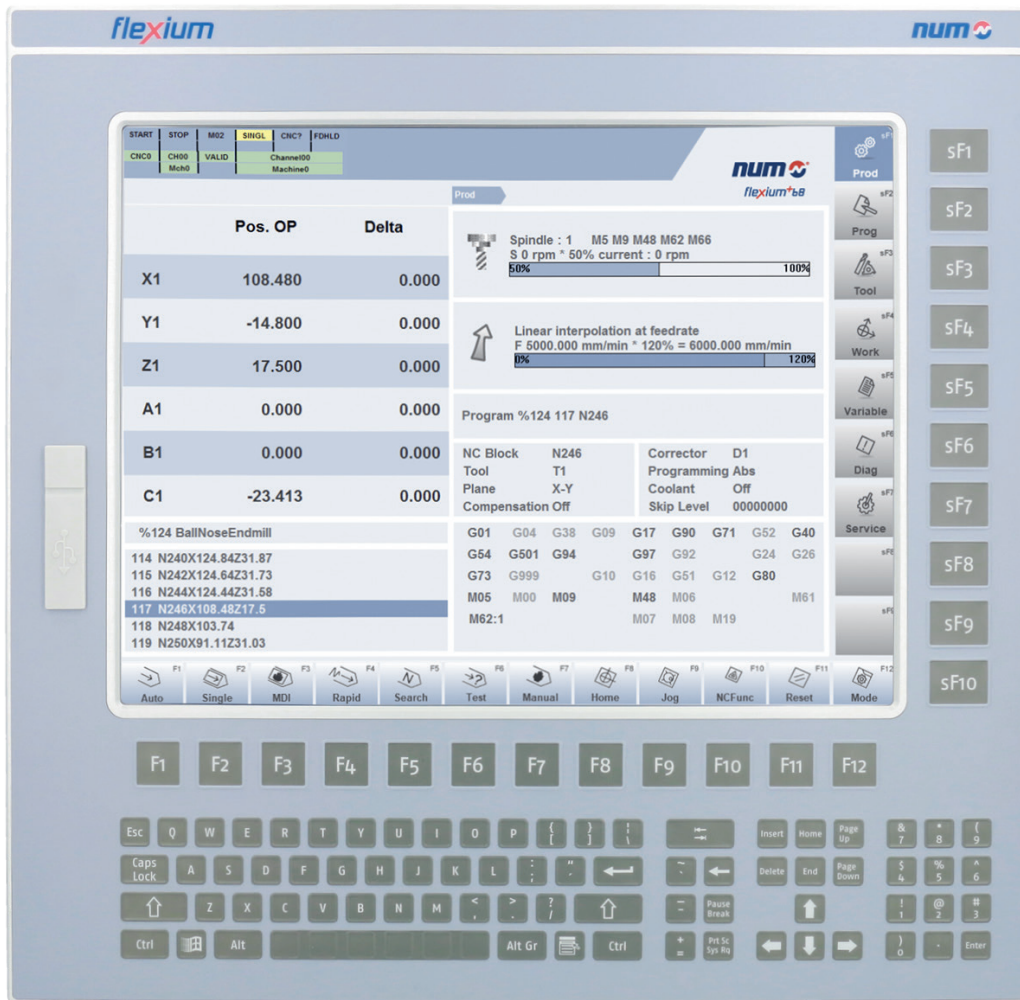

Standard HMI Functions

Developed in HTML and JavaScript for easier customization, the Flexium+ human-machine interface is based on the renowned Flexium HMI and incorporates a completely new graphic design. Whilst fully operational on a 15" operator panel, it is best experienced on the FS194i operator panel, to take full advantage of its 19" multitouch display and virtual keyboard capabilities.

Flexium+ HMI features 7 contexts, each one of these showing all information required. The different contexts are:

- PRODUCTION: Current execution data, Program in progress
- PROGRAMMING: Part program management and editing
- TOOLS: Entering tool offsets, tool wear management
- WORK: Work offsets
- VARIABLE: Display of programming (L., E..) parameters as well as symbolic variables
- DIAG: Machine production diagnostic, Error messages, help ...
- SERVICE: Protected context for HMI setup and some machine diagnostic
- sF8, sF9: Free contexts for customization

Flexium+ HMI includes the basic version of Flexium 3D described below.

Additional languages

The Flexium+ HMI is a multi-language human machine interface designed to offer a comfortable user experience. Users can select any of fifteen different languages:

- | | |
|-----------------------|-------------------------|
| 1. French | 9. Polish |
| 2. English | 10. Russian |
| 3. German | 11. Turkish |
| 4. Italian | 12. Hungarian |
| 5. Chinese Simplified | 13. Romanian |
| 6. Portuguese | 14. Chinese Traditional |
| 7. Spanish | 15. Danish |
| 8. Czech | |

Optional HMI Functions

FXSW282112 Symbolic Names

This function allows names to be assigned to the channels. These names are displayed instead of the usual address numbers, for example on the axes position page and in the status window. The channels can be grouped and assigned to a machine. Part programs can be assigned to the channels. Symbolic names can also be assigned to axes and are displayed in the production context. Symbolic names are used for display purposes. Programming remains in reference with the normalized name of the axes (X, Y, Z...).

FXSW282113 Extended Tool Table

This feature enhances the tool table in the tool context and allows for any tool the addition of:

- A name
- A comment
- A channel

This information is saved together with the tool data in one single file.

FXSW282114 Teach-In

This option adds a teach-in function to the editor in the programming context (sF2). The actual axes positions can be transferred easily into an open part-program.

The following settings are possible:

- Selection of the axes to teach
- Extension of the axes positions with CNC functions (G, M, F etc.)
- Insert a block or overwrite an existing block
- Overwrite only the axes positions of an existing block



PLC Visualization

Flexium+ offers the possibility to create custom screens controlled directly by the PLC application. This is useful for diagnostic or maintenance purpose as well as supervision.

These versions are available:

FXSW282160 PLC Visualization

This brings the possibility to integrate a custom visualization within a frame of Flexium+ HMI. This integration is possible in:

- The production context (e.g. for a virtual machine panel)
- The two free contexts (sF8 and sF9)

FXSW282502 Target Visualization

The PLC visualization runs on the system that contains the PLC real time monitor (generally the PC Panel). It shows a full screen or sizable image running independently of Flexium+ HMI.

FXSW282503 Web Visualization

This brings the possibility to display a full custom visualization via a web interface (browser).

FXSW282500 CODESYS HMI SL

CODESYS HMI SL allows the user/OEM to create operating interfaces with CODESYS visualization for an HMI device (PC or panel). CODESYS HMI SL standard license (FXSW282500) will be delivered with 10.000 data points/variables included. In case that more data points are needed please order additional option FXSW282501, to provide unlimited number of data points.

Option	Reference
CODESYS HMI SL	FXSW282500
CODESYS Runtime Key	FXHE557400
CODESYS HMI SL Unlimited Data Points	FXSW282501



Flexium+ Technology HMI

The Flexium CAM Concept

Flexium CAM is a NUM development framework to create and run Technology HMIs for integrated computer aided manufacturing. Technology HMIs are a set of customized and application dependent UI pages (User Interface) based on HTML and JavaScript created with Flexium CAM Designer. The Technology HMIs are packed and encoded to protect the application.

The Flexium CAM designer tool is a technical HMI creation tool which provides graphically supported, dynamic HMI pages, equipped with data and NC Template editor as well as a configuration setup to design the workflow with user friendly data entry capabilities. This enables the user of the Flexium CAM Designer tool to create application projects tailored to the respective needs.

These “ready to run” projects can be loaded in the Flexium+ HMI software or Flexium Office to automatically generate ISO part programs. With the integrated download functions the part program can be sent to the NCK for execution.

In Flexium CAM framework all languages of Flexium HMI are supported.

The Flexium CAM Engine runs on Flexium+ HMI and Flexium Office. This means that all technological HMIs run on the machine, but also on a PC in the office.

The Flexium CAM Engine is part of the Flexium+ HMI installation and provides all interfaces to load and run the project generated with Flexium CAM Designer.

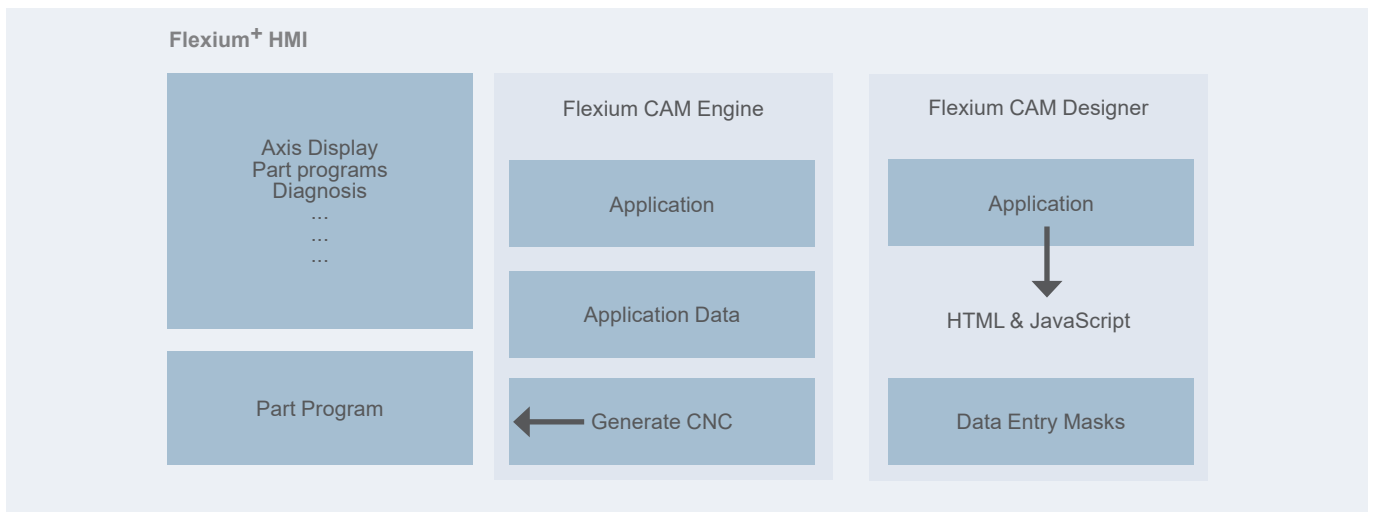

The Flexium CAM product consists of two essential elements:

- Flexium CAM Engine (FXSW282180) Technology Interface on Flexium+ HMI/Flexium Office
- Flexium CAM Designer Tool to design the technology HMI on Flexium+



FXSW282220 NUMgear HMI Hobbing

NUMgear HMI Hobbing is included in Gear Hobbing Packages 1 and 3 for Flexium+.

- NUMgear Hobbing provides everything a customer would need to cut gears on a hobbing machine. NUMgear Hobbing runs out of the box
- There is no need for the operator to write even one single line of NC code. Data entered will be converted to an NC program, sent to the NC, and the machine is ready to run and cut a gear
- NUMgear HMI Hobbing is fully integrated into the Flexium+ HMI
- The user interface is designed for simple and intuitive data entry. Entry fields are named and illustrated with corresponding images

NUMgear Hobbing provides NC programs for a wide variety of applications:

Axial Cycles

- Crowning with optional offset or straight sections
- Up to 3 taper sections
- Selectable dwell after radial and axial infeed
- Diagonal hobbing for taper root
- Single indexing
- Hobbing and milling

Radial Cycles

- Worm gear with optional tangential feed
- Single indexing

Diagonal Cycles

- Cut helical, spur or spline gears as well as taper root splines

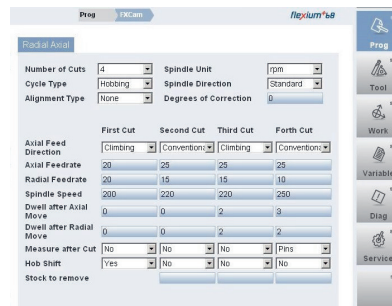

FXSW282221 NUMgear HMI Threaded Wheel Grinding (TWG)

NUMgear Threaded Wheel Grinding (TWG) is available on Flexium+ together with NUM's new multi-level electronic gear box (MLEGB). It is the integrated solution for a threaded wheel grinding machine.

NUMgear HMI TWG provides the graphical user interface to enter all data needed for:

- the gear
- the grinding wheel
- the dressing tool
- process parameters

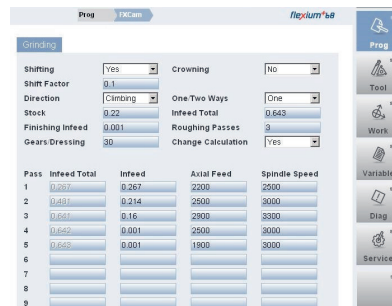

A graphical tool enables flank crowning to be adapted using eight individual points along the flank. The shape of the flank will then be calculated using splines to connect the points changed. NUMgear TWG calculates grinding passes and feeds fully automatically. NUMgear TWG automatically calculates the dressing passes parameters. It provides the possibility to manually change and adjust the values calculated. All gear grinding and dressing cycles are included. Once the process data is confirmed, NUMgear TWG automatically transfers the data generated to the NC and the gear grinding cycle can be started by simply pushing the start button. Tool and gear data are being stored in project files. Project files can be changed and adapted in case of work piece changes. Project files built on one machine can be transferred to several machines to produce the same gear.

NUMgear Threaded Wheel Grinding Pack (FXPA000589) offers all processes needed for threaded wheel grinding:

- Grinding the gear using the process and grinding parameters specified in the NUMgear HMI TWG
- Redressing the grinding wheel after a predefined number of gears
- Dressing a raw grinding cylinder to a grinding wheel according to specification

The new MLEGB allows for utmost precision on the movements of tool and gear, including Z and shifting axis Y.

FXSW282222 NUMgear HMI Shaping

NUMgear Shaping is available on Flexium+ and is an integrated solution for gear shaping machines. Gear data as well as tool data input is made simple and easy by the NUMgear Shaping graphical user interface. Operators can enter gear, tool and process data simply using the HMI. No need to program one single line of NC code. The NC cycles required to run a shaping machine are included in the package.

With NUMgear HMI Shaping, data entered is transferred to the NC and used in the corresponding cycles.



FXSW282223 NUMmill HMI

NUMmill HMI provides graphically supported user pages to simplify shop floor programming in case of milling operations. Configured with a state-of-the-art NUM Flexium+ system and user-friendly HMI software, NUM conversational for Milling is particularly well suited for performing basic canned cycle operations. It offers a complete “off-the-shelf solution” with a user-friendly interactive conversational- graphical interface, which allows the user to operate the machine without prior knowledge of ISO code programming.

Supported functions:

- Hole patterns (arc, grid, row by points and angle, row with two points and drilling with rotary axis)
- Drilling cycles
- Tapping / rigid tapping
- Counter bore
- Ream
- Threading
- Pocket
- Tool selection
- General definition (G17/G18/G19, M3/M4, Coolant)
- ISO block
- Subroutine call
- Motion Request
- Jump to block

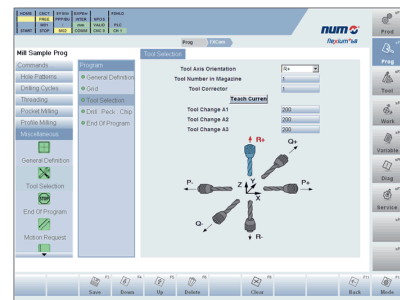

FXSW282231 NUMgrind HMI GC

Configured with a state-of-the-art NUM system and user-friendly software, NUMgrind GC is particularly well suited to address all aspects of the cylindrical grinding process. It offers a complete “off the shelf solution,” with embedded grinding and wheel dressing cycles governed by a user-friendly menu-driven data entry and wizard-guided setup. In short, not only will NUMgrind GC save years of development time, it will also significantly reduce the operator learning curve.

NUMgrind HMI GC is a user-friendly interface. Shop floor programming screen pages provide the machine operator with a comprehensive graphical programming approach that depicts the wheel, the part and associated setup data in a clear and concise manner. The operator does not have to use ISO programming; he or she simply fills in the data fields presented by the program. After completion of the data entry session, the program is automatically generated, stored, and it is ready for execution.

The HMI includes the following features:

Supported Grinding Cycles:

- OD/ID Plunge / Multi-plunge
- OD/ID Plunge with inclined Axes
- OD/ID Oscillating Plunge / Multi-plunge
- OD/ID Cylinder Traverse
- OD/ID Profile Traverse
- OD/ID Taper Traverse
- OD/ID Oscillating Shoulder
- OD/ID Shoulder Traverse
- OD/ID Shoulder Cylinder Blend

Auxiliary Grinding Functions:

- Wheel Data Management (Eight Stored Setups)
- Part Taper “Table Skew” Correction
- Measurement and Part Origin Modification
- Automatic Wheel Profiling
- Automatic In-Process Wheel Dressing
- Full cycle support for In-Process Gauging and Gap Elimination (AE Sensor)
- Active or Passive Z Position Probe
- Straight and Angular Wheels
- Special Profile Wheels
- Import wheel or part profile from CAD system





FXSW282232 NUMgrind HMI Cylindrical + Non-Circular Grinding

This highly modern and clearly arranged HMI makes it possible to create executable grinding programs for cylindrical grinding as well as for non-circular grinding within a very short time.

Due to the easy to fill input masks and the predefined selection masks, you save a lot of time by not having to write any line of CNC code on the machine.

The NUMgrind HMI Cylindrical + Non-Circular Grinding includes all functions of the NUMgrind HMI GC (FXSW282231). In addition, there are functions specifically for non-circular grinding, which are unique.

For example, the HMI provides the user with a large set of 15 predefined external and 2 predefined internal shapes. The shapes only need to be parameterized and no CNC code has to be written.

Additionally, user can insert his own program with defined shapes in Cartesian or polar coordinates into a part (XPI) into the HMI.

The HMI includes the following external shapes:

- Eccentric Circle
- Rectangle
- Square
- Trapezoid
- Wrench Width
- Triangle
- Circle Segment
- Ellipse
- Reuleaux Triangle
- Stadium
- Rhombus
- Egg Shape
- Oval
- Regular Polygon
- Super Circle

It includes the following internal shapes:

- Eccentric Circle
- Pitch Circle

2

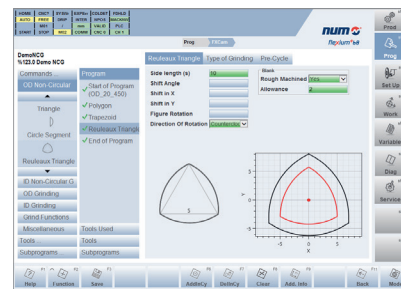
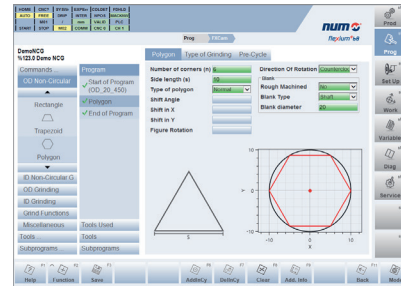

Flexium+ CNC System

System Functions

Flexium+ Technology HMI



FXSW282510 NUMcut HMI Standard

NUMcut HMI Standard provides an HMI for cutting technologies such as waterjet, laser or plasma cutting. The focus of this first version lays on execution of jobs (part programs) visually shown and with the possibility of manipulation (Start, Stop, Re-entry, etc.).

NUMcut HMI is a stand-alone HMI compared to the other technical HMIs as NUMgrind HMI etc. This software runs on a PC integrated in or connected to a Flexium+.

The HMI is divided in different contexts.

Context Pool shows all available jobs (cutting programs). The operator can sort the list by various criteria (name, material, status, etc.) A graphic preview of the jobs is integrated.

Jobs can be added to and deleted from the pool. This happens by hand or by external programs.

The operator can generate a job list out of the pool.

Context Production The job list contains all jobs that were selected from the pool for production. The list's order defines the order in which the jobs will be processed once the operator clicks on start.

For each job the operator can select a predefined datum shift (in NUMcut referred to as frame) in order to place it on the machine bed. It is possible to alter the xy offsets of each datum shift via text box, by clicking into the graphics window or by reading the current machining head position.

Once the machine has started to process the production list, NUMcut provides the user with three options for interruption: "immediately", "at the end of the current part" and "at the end of the current cut".

If execution has been stopped, the operator can specify the point at which machining resumes by clicking on or near the edge of a part, or by clicking on a part or cut in the production list. NUMcut HMI automatically adds the required start-up path at the start point in the case of a non-preprocessed job to be accurate.

The operator also can stop the movement and can set an offset on the path from where production will be resumed.

The cutting process is graphically represented in the production context by a moving crosshair. In order to provide a quick overview of the ongoing production to the operator, there is also graphical highlighting of completed cuts, part, and jobs.

In **context Technology**, technological relevant data is stored. It is used in the cutting process to parameterize the machining operation. The operator can change the data, and add new material types as well as thicknesses.

Context History shows the jobs produced.

The HMI settings are set in the **context Settings**.

Requirements

NUMcut HMI Standard:

- works with Flexium+ 6/8/68 from version 4.1.30.00
- runs on a PC with Windows 7 or higher
- requires a Flexium+ license to run

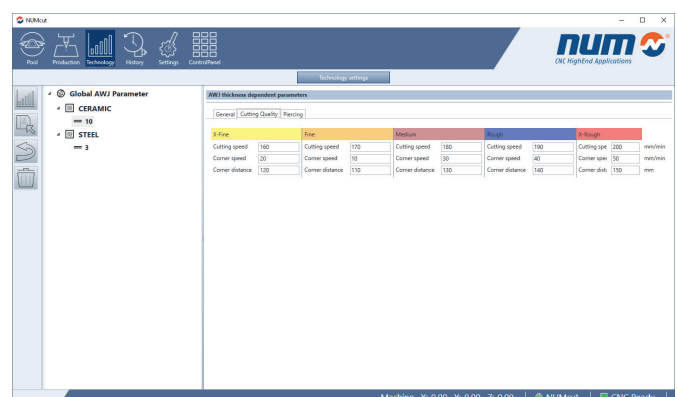
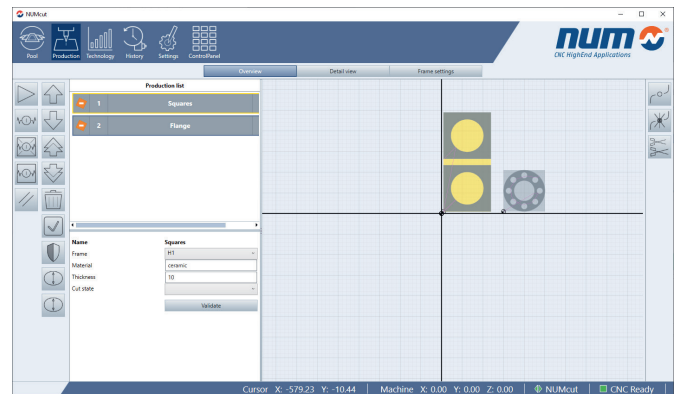
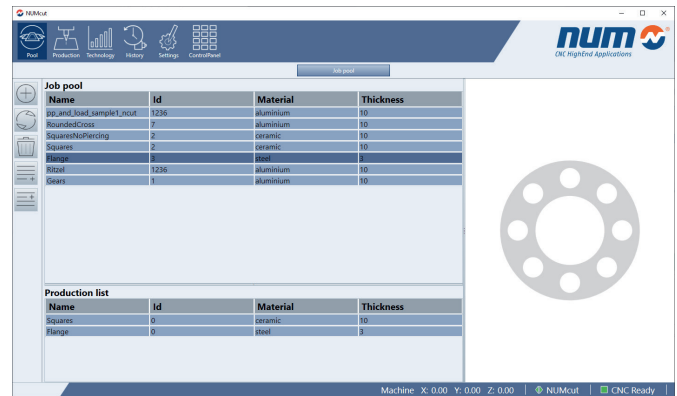



NUMmonitor

In the field of high-production machines the smallest incident may lead to huge economic consequences; this is why it's important to monitor the machining parameters in order to prevent down times due to a worn tool, a lubrication fault, a loss of performance or anything else.

NUMmonitor, fully integrated in Flexium+, implements such a real time process control without the need of additional sensor/hardware.

The first step is to record machining parameters in optimal conditions. The most significant of these measure points is the motor load. NUMmonitor will then provide the possibility to record the load of up to eight motors. These parameters are recorded based on machining time to ignore variations due to different cutting conditions. Several recordings can be performed to calculate an average value. Based on these recordings an envelope with vertical and horizontal tolerance is then build and stored in a database in a file representative of the part being machined. An example of this recording is shown here. The green curve displays the recorded load whereas the red curves define the acceptance area.

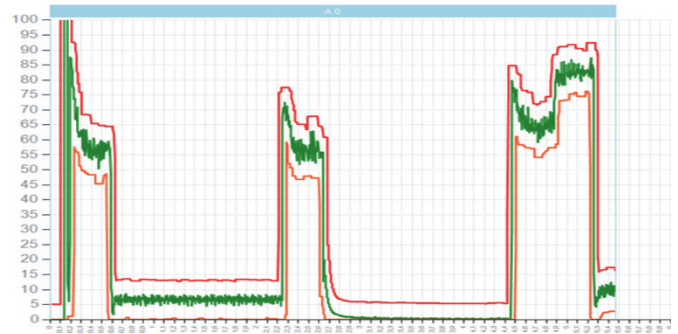

2

Once the phase of 'teaching' has been completed it is possible to start production with the same part program that was used for creating the model. If a discrepancy on any of the motors monitored is detected then it is signaled to the PLC which will decide which action should be taken: from a simple warning to an emergency disengagement. At the end of the measuring session the part program will send a request to close the recording. The various checking conditions can be mixed using OR and AND operators to obtain the alarm condition, and of course, the monitoring can be limited to some sections of the process.

Optional NUMmonitor Functions

FXSW282313 **NUMmonitor Basic License**

2 traces (variables) recorded and displayed simultaneously.
PLC interface not available.

FXSW282315 **NUMmonitor Extension**

8 traces (variables) recorded, displayed and controlled simultaneously.
PLC interface available.



Flexium Office

Working with Flexium Office

Flexium Office permits the use of NUM's Technology HMIs without connection to a machine - for example, in the office. Application dependent projects, and the corresponding ISO part programs, can be created, tested with NUM's Flexium 3D simulation software and transferred to the targeted machine.

The operator selects one of the provided Flexium CAM HMI technologies. With basic data definition, tools and workflow commands as well as language support for 15 languages, the project (xpj) for the concrete application is generated once.

The file handling for projects on the local PC is divided into project "Save/Save as" or for evaluation purposes "CNC Program" to generate the CNC part program (xpi) direct locally on your PC.

The most significant user benefit of Flexium Office is that the process and real workflow can be organized and tested in the office, in advance, if you generate the CNC part program locally for the simulation. The production machines are free only for real part processing; which clearly increases the machine efficiency.

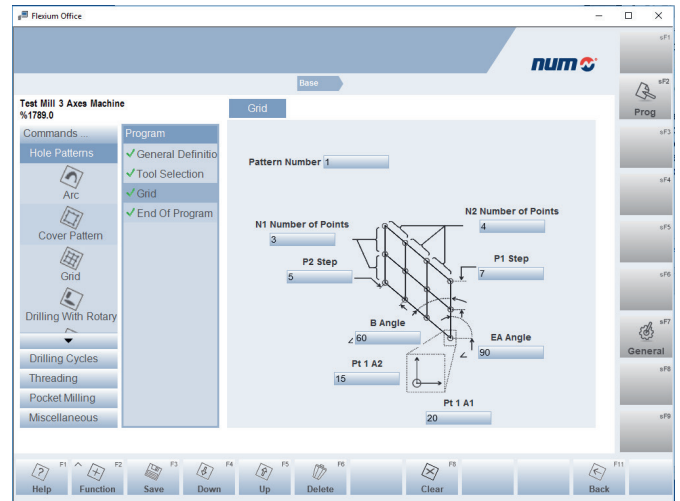

Flexium Office Options

FXHE557200 Flexium PC Dongle

This dongle is needed that Flexium Office runs on a PC.

FXSW2822xx NUMxxx HMI

The desired technology HMI must be ordered in addition for the corresponding Flexium PC dongle.



Standard Flexium 3D Functions

Flexium 3D is a 3D graphical simulation software for part programs written in ISO-Code (DIN 66025 with NUM dialect), which exists in different versions for milling, drilling and/or turning applications as well as water jet and plasma cutting.

During the part program simulation the path of the TCP (tool center point) is visualized, the material removal on the work piece is simulated and a collision check is made between machine components, part and tools.

Operating the software is oriented on mouse and keyboard usage as well as single and dual touch gestures.

Flexium 3D takes as input the machine configuration (e.g. machine parameter, kinematics and physical parts, tool library, blank and collet definition), offset table and the NC program (part program).

An ISO-parser is integrated inside the host application (simulation), which analyzes the part program, makes all tool length and tool radius compensations as well as offset transitions and rotations, and substitutes mill-, drill- and turning cycle definitions with real movements.

The wired path simulation is standard. According to the type of machine (T or M), optionally mixed configurations, material removal as well as collision checking are available.

Two versions are available:

- Office version: used as a standalone program preferred in production planning without CNC (Dongle is needed)
- Machine version: integrated in the Flexium+ HMI for pre-simulation or in online synchronization to the machining

Optional Flexium 3D Functions

FXHE557200 Flexium PC Dongle

The dongle is required to run Flexium 3D outside a Flexium+ system.

FXSW282150 Simulation for Turning

The base system should be ordered as a turning or milling system.

FXSW282151 Simulation for Milling

The base system should be ordered as a turning or milling system.

FXSW282152 Simulation Mixed T & M

Once the base system is chosen, this option gives the possibility for simulation of both turning and milling.

FXSW282153 Simulation with Material Removal

The base system displays the tool path. This option also allows the blank part and material removal to be displayed during the process.

FXSW282154 Simulation with Collision Detection

This feature shows possible collisions during simulation. The software will show the number of collisions, their location on the part (with a red box) and in the part program (blocks highlighted in red). During setup it is possible to select which kind of collision should be detected. In order to work safely, this option will require the machine to be accurately described.

FXSW282155 Online Simulation

This function is available on the machine version. It allows the simulation to be synchronized to the actual movements of the axes, to show the process in real-time.

FXSW282158 Flexium 3D – Path Editor

This optional 3D-Path Editor is released only for all Flexium+ platforms and allows a graphical/text supported path optimization/reworking of digitized or CAD/CAM generated part programs in 6 axes. Principle of the mode is a very fast visualization of the programmed ISO trajectory in program frame for the most interpolation commands (except polynomial interpolation) without using the PcParser-tool. It can be also used as a simple part program editor with simultaneous graphical path display.

- 3D-Path View: visualization of the complete trajectory of the part program (PP) in default plane view (G17). The white cross highlights the current PP line
- 3D-Text View: the text window of the selected part program with syntax highlighting, dynamic edit command box, command line editor for adding/deleting lines, 'multi-line edit' and visualization of the current PP line
- Plane selection and helpful operation controls
- Parameter/value edit box with slider controls
- Complete file handling controls
- Complete file handling controls
- Progress bar

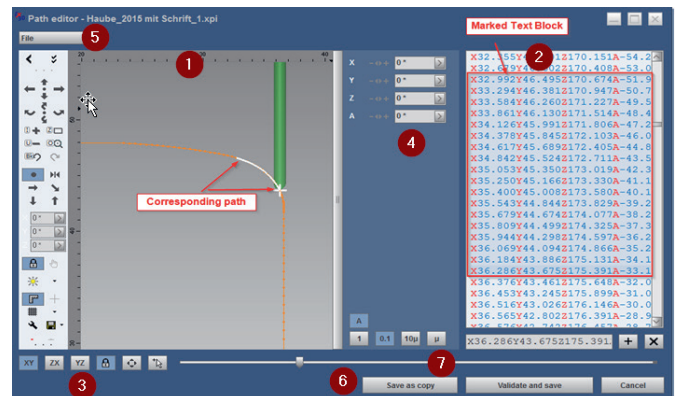

FXSW282157 Flexium 3D SEARCH Mode

The present SEARCH Mode for Flexium+ has been extended with a graphical supported method inside Flexium 3D. The same operating philosophies are valid for HMI with the SEARCH Mode initiating from Flexium 3D.

Targets and customer benefits are:

- Integration of a graphical extended SEARCH Mode in Flexium 3D and NCK firmware
- Preview of loaded part program with fast offline simulation of TCP path
- Definition of re-engage position (also within a NC block) with mouse or touch operation
- Specification of different and flexible approach strategies depending on the application
- Execution of a sub-program with programmed movements, machine functions and other NUM ISO-dialect in re-engage process

To use graphical supported SEARCH Mode on Flexium+ systems the HMI option Flexium 3D Online-simulation (FXSW282155) is required.

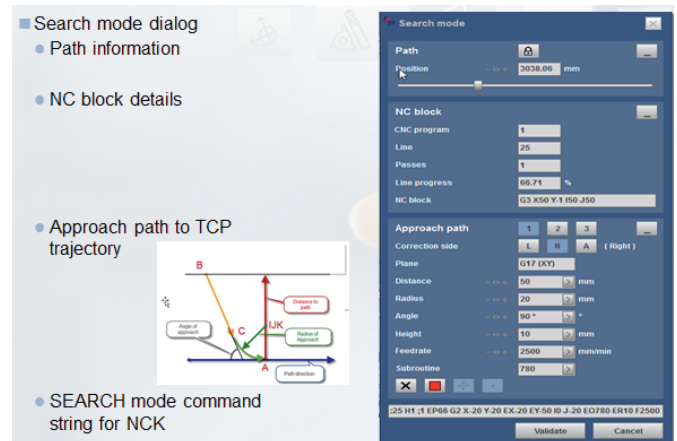

Variants:

From this geometrical consideration three variants for the approach path to the TCP trajectory are possible (references are the red approach contours):

- Direct vertical approach to TCP trajectory
- Tangential approach with circular element
- Tangential approach with circular and linear element

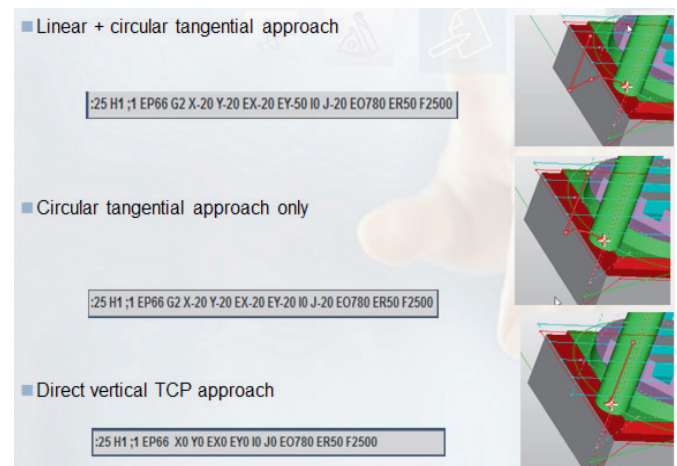



FXSO000521 Online Collision Detection with Flexium 3D

Collision calculation in general

Since its initial release more than 10 years ago, the Offline collision detection remains an integral element of NUM's Flexium 3D Simulation software. A significant advantage and competitive differentiator of NUM's collision detection, is the consideration of the actual blank dimension and the removed material during collision calculation. Not only does Flexium 3D consider the tool path, it also includes the tool dimension, tool orientation, tool holder and all other machine components simultaneously to prevent collision.

Enhancement to Online collision detection using Flexium 3D for manual Move

As machining processes become more and more sophisticated, the risk of collisions between the tool, workpiece and machine components increases. Collisions mean costly downtime and cause expensive damage to the workpiece, spindles and sometimes even the whole machine.

Flexium 3D features together with NCK extensions form new functions which allow monitoring and preventing online collisions during manual/handwheel jog or in Search-mode (part program resume) and in commissioning phase. To reach this target axes dependant collision free limits are calculated and transferred to NCK before the axis move is released.

Even in critical 5-axes machining cases including complex blank shapes, active RTCP or Tilted plane transformation, manual motion online collision detection, makes operation simpler and safer!

Collision detection highlights:

- Possibility to configure safe distances for different machine components (tool, blank, collet and machine parts) individually
- Status synchronization of Online Collision detection for Flexium HMI and Flexium 3D
- Graphical supported visualization of collision components
- Operator messages indicate the axis and direction of collision
- Prevention of movements in the collision state
- Multi axes motion of RTCP/Tilted plane are supported

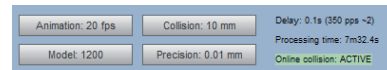

HOME	CNC2	SYSW	EXPErr	COLDET	FDHLD
MAN	1000	DRIP	INTER	TRPOS	MACKHW
START	STOP	M02	COMM	CNC 0	CH 1

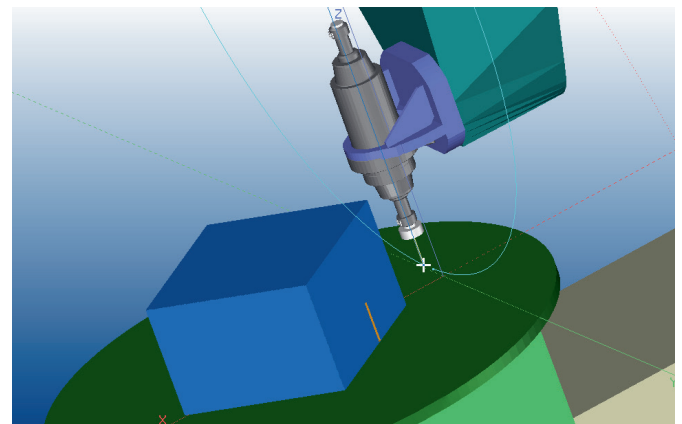

Standard NUMconnect Functions

OPC DA

OPC (Open Platform Communications) is a standard defining the communication of real-time plant data between control devices from different manufacturers. The most common OPC specification is OPC Data Access (OPC DA), which is used to read and write real-time data. The OPC DA server supports the specifications of OPC Common Definitions and Interfaces, Data Access Custom Interfaces, Data Access Automation Interface and Alarms and Events Custom Interface. OPC DA is a basic function of the Flexium+ and it is connected PLC.

Optional NUMconnect Functions

FXSW282509 NUM IloTgateway

NUM IloTgateway has been developed as Industry 4.0 solution and offers the protocols:

- OPC UA
- MQTT
- MTConnect

Normally, one protocol is selected during configuration. Nevertheless, it is also possible to select two or all.

NUM IloTgateway provides following information over all protocols:

- Machine Information
- Production plant, production line, machine name, etc.
- Machine State
- Actual status, alarms, etc.
- Different NCK topics like actual operating mode, feed rates, program name, etc.
- Actual information about the job state: Start time, end time, number of pieces done, etc.

In case a NUMROTO software is installed on the machine, it also provides:

- NUMROTO version, machine number, machine name etc.
- Job type, job name, tool number, tool name, job start time, etc.
- Tool information: Name, comment, blank length, blank diameter, package ID etc.

NUM IloTgateway can read information from:

- Flexium 6/8/68 from version 3.6.00.00 (recommended as the lowest version)
- Flexium+ 6/8/68 from version 3.6.00.00 (recommended as the lowest version)
- Axium Power from revision R2 (lowest supported version)
- Num Power from revision R2 (lowest supported version)

NUM IloTgateway runs on a PC with Windows 7 or higher.

NUM IloTgateway consists of:

- The software itself (NUM IloTgateway)
- A Configuration Tool (NUM IloTgateway Settings)
- A Display Tool for the Windows Notification Area (System Tray)

NUM IloTgateway Settings

Protocols Control Parameters Machine Information PLC Variables E-Parameters

Connection

OPC UA MTConnect MQTT

OPC UA Security Settings

Enable Security Unencrypted and Encrypted connection by Default Setting: False

Enable Security Encrypted connection only by Setting: True

Port 48030

MQTT Broker

Id *MachinelIdentifier*

Prefix *TopicFilter*

Startup Behaviour Send all data

Host chtemq02.num.s-motion.com Port 0

Encryption

SSL/TLS No SSL /TLS

SSL/TLS Version

NUM IloTgateway UI v1.0.0.268

OPC UA

OPC UA (Unified Architecture) is a protocol specified by the OPC Foundation. It allows not only for transportation of machine and plant data, but also for a semantic description of these data in a machine-readable method. OPC UA is a platform independent standard based on TCP which is also available on NUM's controllers.

The OPC UA server supports the following features:

- Browsing of data types and variables
- Standard read services
- Notification for value changes: Subscription and monitored item services
- Encrypted communication according to "OPC UA standard (e.g. profile: Basic256SHA256)"

MQTT

MQTT is an open message protocol. It is designed for connections with remote locations. An interesting aspect of an MQTT server ("broker") is that it caches the data of its communication partners and can thus be used as a status database. It collects data from various devices and creates a complete situation picture. The data can be subscribed to the MQTT broker and evaluated upon receipt.

On the other hand, control variables from one or more communication partners can also be transmitted to the MQTT broker and distributed to the individual devices. This makes MQTT very suitable for automation solutions.

MTConnect

MTConnect is a protocol for data exchange between production facilities and software applications for monitoring and data analysis. It is designed specifically for the shop floor environment and is based on XML and HTTP Internet technology. MTConnect compliant devices process information locally and then provide that data in a consistent format to any MTConnect compliant application - ERP, MES, and Production Management Systems.

MTConnect Most Basic Architecture

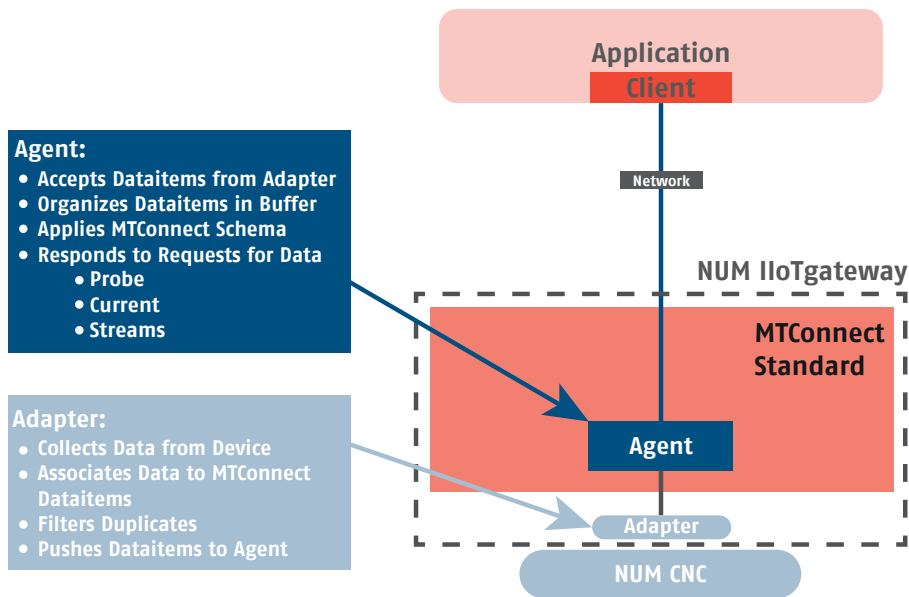



Flexium Tools Standard Functions

Flexium Tools is part of the Flexium Suite and includes all functions needed for the integration and commissioning of the machines. Flexium Tools allows users to program, configure and optimise system components within a unique environment:

- PLC
- Flexium NCKs (CNC)
- Servo drives and motors
- Sensors
- EtherCAT and CANopen gateways with a comprehensive set of I/O and logic terminals

Easy Operation

The menu structure of Flexium Tools provides a perfect overview of the entire system. Navigation inside the device tree is simple and clear, allowing easy access to all functions for quick change of settings.

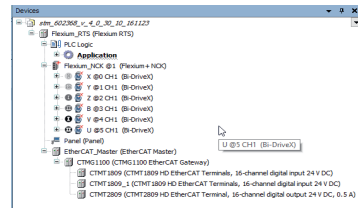

Project Handling

Access rights can be defined for different users. Each project consists of one single file to ensure easy handling and to prevent data losses. New equipment or versions are quickly integrated using EDS for CANopen devices and Device Descriptions (DevDesc) for NUM devices. Libraries can be used in different versions and can be compiled to protect know-how. Complete projects, including libraries, devices and the source code can be archived, thus making restoration possible at any time in the future.

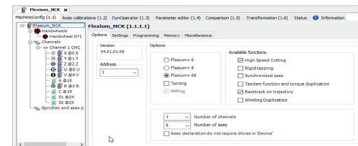

PLC System Programming

The PLC of the Flexium system is programmed in accordance with IEC 61131-3 and allowed different graphical supported programming environments. For more details see next pages.

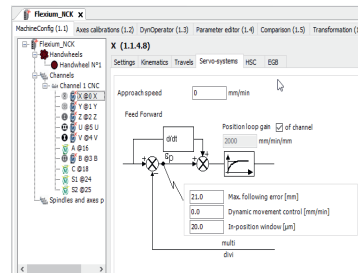

Flexium NCK (CNC) Parameterising

Dedicated editors for options, programming, memory, channels, axes (with individual windows for settings, coupling, kinematics, travels, servo system, HSC) miscellaneous hand wheels, axes calibration and more ensure easy handling and the best overview during editing.

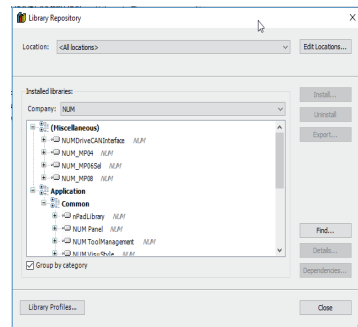

Servo Drives Parameterising

All servo drives of the Flexium system can be found and accessed easily in the menu structure of Flexium Tools. For better overview, the structure is displayed in the way the system is set up, e.g. servo drives are listed under the controlling Flexium NCK.

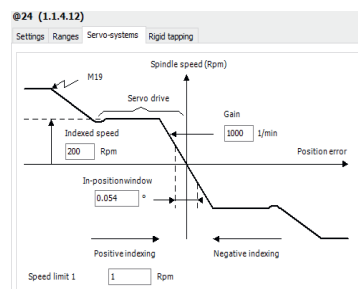

Flexium+ CNC System

System Functions

Flexium Tools

Field Busses

Theoretically, any CANopen and/or EtherCAT compatible device can be connected to the bus using the EDS/ESI/XML file supplied with the device. NUM provides a comprehensive range of most common I/O components based on EtherCAT technology (EtherCAT = Ethernet for Control Automation Technology). It is the real-time Ethernet technology standardized by EtherCAT Technology Group.

NUM provides machine panels, drives for auxiliary axes and other devices that, by means of dedicated windows and libraries, can be easily integrated as field bus devices (EtherCAT or CANopen).

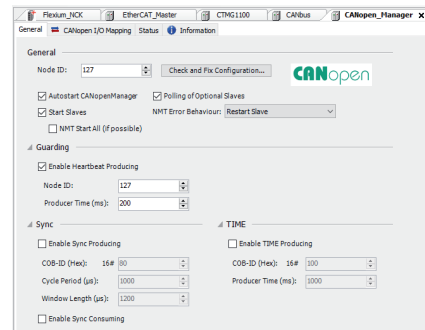
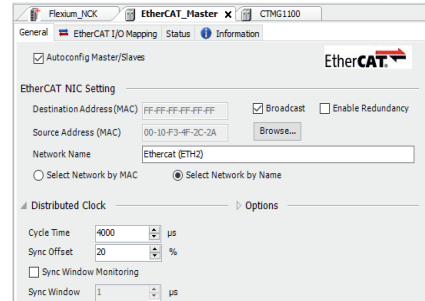

Instruments

For easy commissioning, a huge set of instrument tools are available in Flexium Tools.

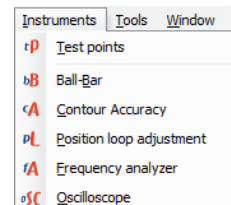

Ball-bar

The Ball-bar function is a tool which uses the internal NCK ring buffer to record reference and the real position of 2 given axis, while doing a circular motion. The display of the real position can be used to identify the different axis characteristics like reversal spikes (pitches), transmission errors or wrong position loop gains. While displaying the axis motion it can be used to optimize the parameters for pitch compensation and high-speed cutting.

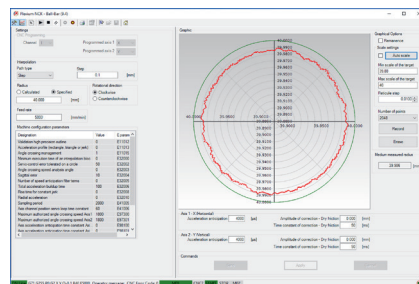

Oscilloscope

The oscilloscope tool is used to set up the recording and to display drive internally measuring point data. Up to 2 channels of any measure point can be recorded in sampling frequencies up to 10kHz. Triggers can be used for recording issues, such as drive alarms, threshold values of any measuring point or stimulus functions. The stimulus function can be used furthermore for tuning and testing purposes. The integrated graphics can display up to 4 different measurements for comparison purposes. To analyze the recorded data, cursor functions are available as well as storing and loading of recorded data. Further information on how to use the recorded data for tuning purposes can be found in the Manual.





Frequency Analysis

For speed loop and position loop tuning purposes a frequency analyzing tool is available with the Flexium Tools Instruments. For any of the axis of a machine an overlaying white noise signal for speed or position is generated and introduced into the appropriate control loop. The reference and the resulting motion is recorded with the drive internal oscilloscope and displayed in a Bode-Diagram. Cursor functions are available to analyze the recorded data as well as multiple channels for storing different recording.

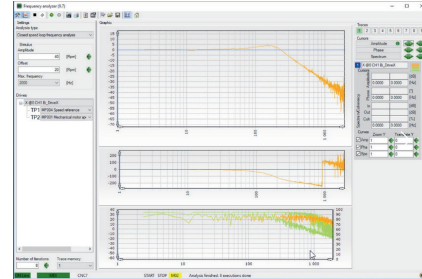

Contour Accuracy

The contour accuracy tools can be used for analyzing purposes of the axis behavior as well. The tool uses the internal NCK buffer to record reference and real position of 2 axes. The recording is started as soon as the axis enters the “departure windows”. The axis errors are displayed with an “expansion scale” so that they are clearly visible. The tool also calculates the speed and acceleration values out of the recorded data, which can be helpful for analyzing purposes.

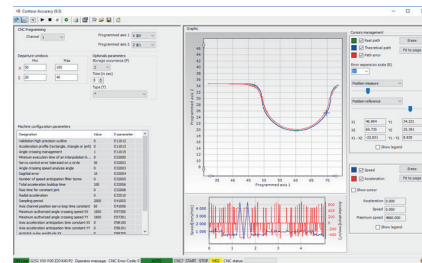

Test Points

Within the Flexium-Tools instruments exists also a displaying page of up to 8 drive test points. The display can be used to show current measure point data as well as buffering their minimum and maximum value. With up to 8 simultaneously displayed measure points the data from 2 drives with all 4 measure points or 8 axes with only 1 measure point can be displayed at the same time.

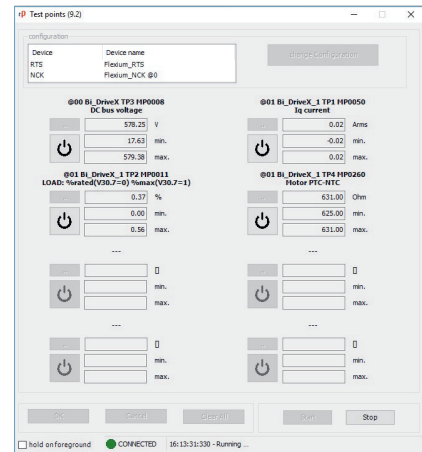

AutoTuner¹

NUM proposes a different Auto Tuning methodology; the machine’s operator just needs to run an ISO part program which moves the axis to be tuned, an observer starts to estimate different physical variables: axis total inertia, friction in both directions, vertical loads if any and resonances.

Based on these estimations, the NUM autotuning function, proposes: proportional and integral speed loop gains, encoder low pass filter, maximum position loop gain and the most critical vibration mode. Without the need of a specific speed/position stimulus, NUM autotuning can also be used during normal machining and it’s suitable for optimizing axes which are subject to condition’s changes. It can tune whatever type of motor: rotary synchronous, rotary asynchronous, linear, torque motors... including vertical axes, hydraulically balanced axes and spindles.



¹ Available with Flexium version 4.1.10.0 and higher

PLC Programming

The logical and easily manageable development environment offers dedicated tools for development, commissioning and maintenance. The PLC program structure is displayed in a logical structure showing the different blocks and folders. The program editors can be opened in the following languages:

- Instruction List (IL)
- Ladder (LD)
- Function Block Diagram (FBD)
- Structured Text (ST)
- Sequential Function Control (SFC)

The PLC provides libraries for system functions, customer functions and its own programming functions.

Task management is very comfortable and can be cyclic, event-controlled or freewheeling.

Data and variables are based on a high level language such as C. Data types can also be user defined.

The program can be easily structured using program building blocks, functions and function blocks with entities.

Object oriented programming is also supported and allows safe programs using objects, methods, properties, actions, interfaces and inherit functions.

PLC in a Multi-NCK System

A multi-NCK system for large systems can consist of up to 16 NCKs connected to a single PLC.

This concept ensures the highest performance and makes configuration as well as operation simple and easy. Even large multi-NCK systems - such as transfer machines - present themselves to the programmer and the operator as one single system.

```
1 PROGRAM ENA_Axespositions_OP
2 VAR
3   R_Axis_OP_active:BOOL; // R_Axis_OM test active
4 // axes positions by axes-address
5   O_R_Axis_OP_0:R_Axis_OP;
6   O_R_Axis_OP_1:R_Axis_OP;
7   O_R_Axis_OP_2:R_Axis_OP;
8   O_R_Axis_OP_3:R_Axis_OP;
9   O_R_Axis_OP_4:R_Axis_OP;
10  O_R_Axis_OP_5:R_Axis_OP;
11  O_R_Axis_OP_6:R_Axis_OP;
12  O_R_Axis_OP_7:R_Axis_OP;
13
14 IF (Flexium_NCK.CommunicationReady) THEN
15   IF R_Axis_OP_active THEN
16     //*****
17     // axes positions by axes- address
18     //*****
19     // Settings for axis position reading
20     O_R_Axis_OP_0(CNCAdr:=ADR(Flexium_NCK), byChannel:=0);
21     O_R_Axis_OP_0.enable :=TRUE;
22     IF (O_R_Axis_OP_0.uiResult = 0) THEN
23       q_di_Axis_OP[0,0]:=O_R_Axis_OP_0.Axis[0].Position;
24       q_di_Axis_OP[0,1]:=O_R_Axis_OP_0.Axis[1].Position;
25       q_di_Axis_OP[0,2]:=O_R_Axis_OP_0.Axis[2].Position;
26       q_di_Axis_OP[0,3]:=O_R_Axis_OP_0.Axis[3].Position;
27       q_di_Axis_OP[0,4]:=O_R_Axis_OP_0.Axis[4].Position;
28       q_di_Axis_OP[0,5]:=O_R_Axis_OP_0.Axis[5].Position;
29       q_di_Axis_OP[0,6]:=O_R_Axis_OP_0.Axis[6].Position;
30       q_di_Axis_OP[0,7]:=O_R_Axis_OP_0.Axis[7].Position;
31       q_di_Axis_OP[0,8]:=O_R_Axis_OP_0.Axis[8].Position;
32     END_IF
33   END_IF
34   O_R_Axis_OP_1(CNCAdr:=ADR(Flexium_NCK), byChannel:=1);
```

Optional Functions

There is no option required to develop any case of Flexium+ application.



Flexium+ PLC Standard Functions

Flexium+ PLC is a software PLC running under a real time system (RTS) and therefore largely independent of Windows.

Flexium+ PLC runs on NUM devices (PC Panels FS154i or FS194i or Box PC). Consult us for other hardware.

Flexium+ NCK/PLC Exchanges

Communication with the NCK through RTE (Real Time Ethernet) exchange of process data like:

General Read Data

- Current modes, JOG increments, CNC error number, CNC active, external parameters
- CNC and machine status
- Active program number
- Axes data (initialized, moving, clamped, axis state)
- Spindles (status, speed)

Channel Specific Read data

- Channel states, G functions, current modes
- Encoded M functions without acknowledgement, on-the-fly
- Encoded M functions with acknowledgement
- 34 decoded M functions
- Tool number

General Write Data

- Control of axis jogs, mode control, error messages
- Selection of channels, program numbers
- Processing of spindles, potentiometers, commands, set points
- Inhibiting of certain modes, jog commands, feed rates
- Torque and reference enable for digital axes
- External parameters

Channel Specific Write Data

- Machine functions
- Axis feed-rate override potentiometer for all channels

Flexium+ PLC/Machine Exchanges

Flexium+ PLC communicates with the machine via a field bus, CANopen or EtherCAT. The one CANopen and the EtherCAT interface is standard on Flexium+ 68.



Flexium+ PLC Optional Functions

FXSW282124 Extended NCK Access

This function provides the option of accessing NC Data which are not exchanged cyclically (e.g. current axes' positions, machine parameters, all external parameters, ...) as well as providing access to the part program memory for uploading, downloading, memory available, directory.

FXSW282305 EtherCAT Safe PLC

The TÜV certified option allows to extend a project with an EtherCAT controller for the development of safety functions with TÜV certified safety logic modules (e.g. CTMP6900, CTMP1960-2600) and digital FSoE I/O modules (e.g. CTMS1904, CTMS2904, CTMS2912) in the EtherCAT network. The extension with safety-specific editors and configurators is integrated seamlessly into Flexium Tools. It enables cost effective and scalable realization of simple safety applications with zero system integration or adaptation effort and low acceptance expenditure.

FXSW282306 EtherCAT Profibus Master CTMT6731

License option needed to run the EtherCAT Profibus Master (CTMT6731).

FXSW282312 EtherCAT IO-Link Master CTMT6224

License option needed to run the EtherCAT IO-Link Master (CTMT6224).

FXSO000430 First CANopen Interface

Connection and license for a first CANopen bus. This feature is standard on Flexium+ 68.

FXSO000432 Second CANopen Interface

Connection and license for a second CANopen bus. This feature is only available on Flexium+ 68.

NVRAM Memory for Systems with CANopen

Access to 56 Kb of NVRAM memory for PLC variables. This feature depends on the type of PC-Panel ordered.



NUMSafe Architecture

The NUMSafe architecture is based on a Safe PLC (CTMP6900, CTMP1960-2600), Safe I/Os (CTMS1904, CTMS2904 and CTMS2912) and NUM-SAMX connected through the EtherCAT field bus. The safe PLC contains the programmed logic of the safety application, while the safe motion monitoring functions are handled by NUM-STO and NUM-SAMX module built into NUMDrive X servo drives (see chapter 5).

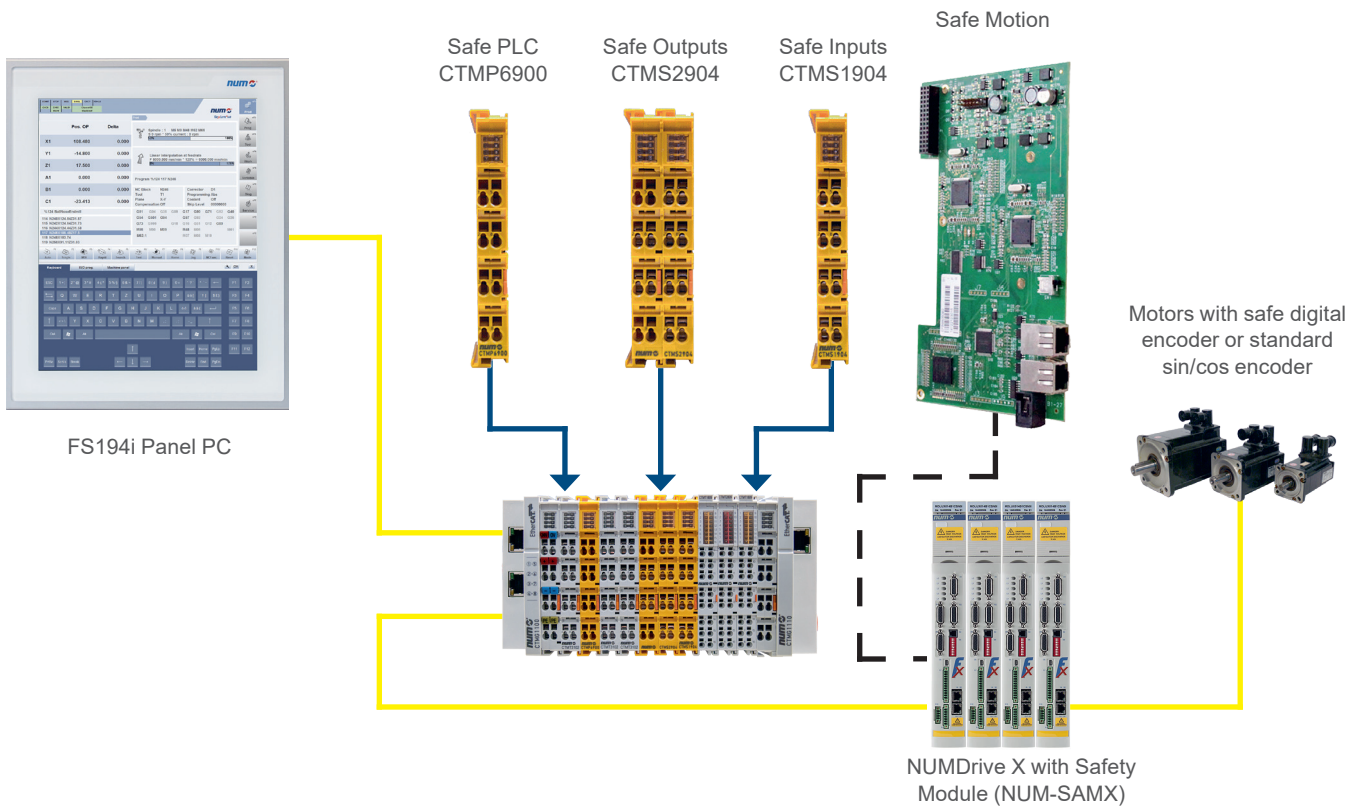

NUMSafe is a comprehensive solution for the functional safety management of each machine type. Architectures with mixed standard and safety related signals are possible (the safe PLC and I/Os can be positioned inside a standard terminal line up). All safety related and NON safety related data are transferred over the standard EtherCAT connection (FSoE), reducing wiring to the minimum and maximizing flexibility and scalability. The safety related devices are configured and programmed by means of the Flexium Tools.

NUMSafe is compliant with EN 13849-1 and EN61800-5-2 up to PL e and SIL 3 respectively.

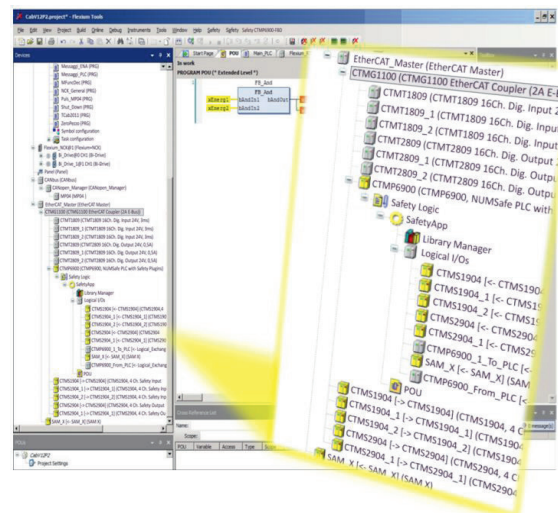

NUMSafe Standard PLC Functions

NUMSafe PLC can establish 128 connections to other NUMSafe devices. Multiple NUMSafe PLCs are cascadable within a network. Safety functions such as emergency stop, safety door monitoring, two-hand control, etc. can thus easily be selected and linked. All blocks can be freely connected among each other and are complemented by operators such as AND, OR, etc. The required functions are configured via Flexium Tools and loaded into the CTMP6900 (or CTMP1960-2600) NUMSafe PLC via the fieldbus.

The available function blocks are:

FB_AND

Using the FB_AND function block, several input signals can be ANDed to make an output signal. In addition, a setting can be made for each input as to whether it is to be negated. This can be switched over using the „Negation“ command from the context menu.



FB_CS

A NUMSafe connection can be deactivated via the FB_CONNECTION SHUTDOWN function block. If the input of the block becomes active the connection is terminated, a shutdown command is sent to the FSoE partner and a feedback signal is provided at the output. Furthermore, the connection is terminated and the output is set if a shutdown command is received from the communication partner.

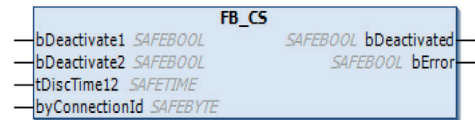

FB_DECOUPLER

The FB_DECOUPLE function block serves to decouple signals from a NUMSafe connection. The function block has 8 inputs and 8 outputs, wherein the inputs are looped through to the outputs one-to-one. The corresponding output must be linked as soon as one of the inputs of the block is used. This also applies in the reverse direction.

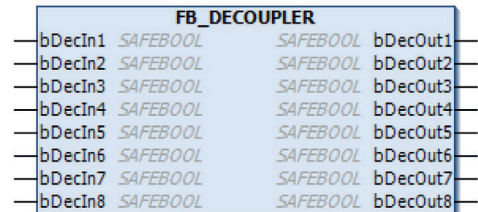

FB_EDM

The FB_EDM function block (External Device Monitor) monitors the signals bMon1 and bMon2 over time. A switch-on and a switch-off monitor can be configured. In the default condition both monitors are inactive.



FB_ESTOP

An emergency stop circuit with up to eight emergency stop inputs (bEStopIn1 - bEStopIn8) can be implemented with the FB_ESTOP function block. Each of the eight inputs can be negated using the „Negation“ command from the context menu. As soon as an input requests the safe state, the first output (EStopOut) immediately enters the safe state („0“) and the second output (EStop-DelOut) enters the safe state after a configurable time delay.

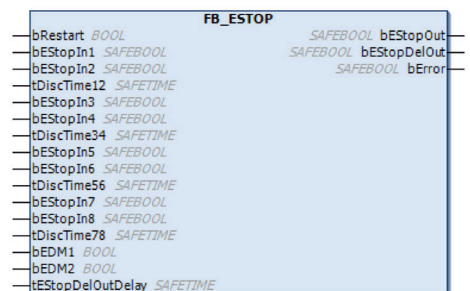



FB_MON

A safety door circuit with up to four inputs (bMonIn(x)), for example, can be implemented with the FB_MON function block. Each of the four inputs can be realized as a normally closed contact (break contact - 0 requests the safe state) or as a normally open contact (make contact - 1 requests the safe condition). As soon as an input requests the safe state, the first output (bMonOut) immediately enters the safe state („0“) and the second output (bMonDelOut) enters the safe state after a configurable time delay. By linking the FB output to several outputs, several immediately switching-off outputs (bMonOut) or delayed switching-off outputs (bMonDelOut) can be implemented with just one FB_Mon.

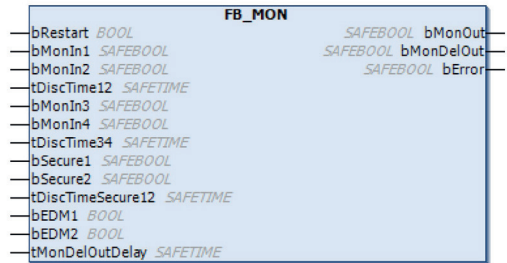

FB_MUTING

The FB_Muting function block implements an intended suppression of the safety function e.g. for the transport of material into the safety area. The output of the function block remains set even though the connected sensors are interrupted.

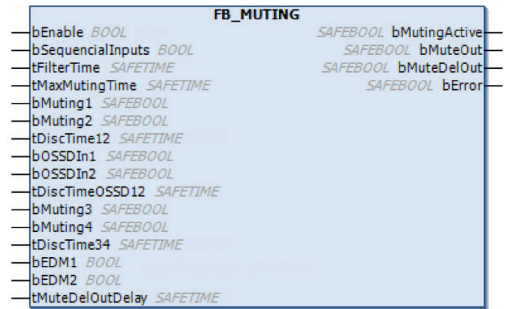

FB_MODE

Operating mode selector switches can be implemented with the FB_MODE function block. The function block has 8 inputs and 8 outputs, which are looped through one-to-one, whereby up to 8 different modes of operation can be selected. The FB_MODE sets the corresponding output only if precisely one input is set („1“); the other outputs remain in the safe state („0“). If no input is set or if more than one is set, all outputs are in the safe state. If the bRestart input is activated, the safe state of the outputs is quit at the start and when changing the operating mode only via a 0->1->0 signal sequence at the Restart input. Beyond that a discrepancy time can be specified at the tDiscTime input with which the change from one mode of operation to the next is monitored.

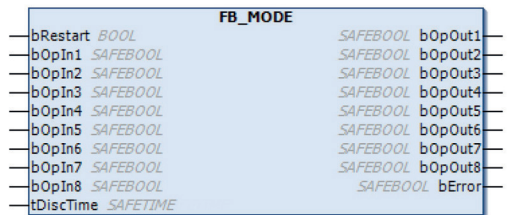

FB_OR

Using the FB_OR function block, several input signals can be ORed to make an output signal. In addition, a setting can be made for each input as to whether it is to be negated. This can be set using the „Negation“ command from the context menu.





FB_RS

The FB_RS function block realizes a Reset/Set function. A logic 1 at the bSafeSet input and logic 0 at the bSafeReset input leads to a logic 1 at the output. A logic 0 at the bSafeSet input and logic 1 at the bSafeReset input leads to a logic 0 at the output. If both inputs are at logic 1, the Reset signal is dominant and leads to a logic 0 at the output. If both inputs are at logic 0, the output remains in its current state.

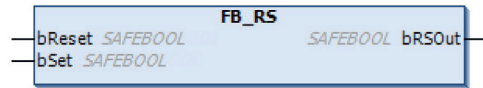

FB_SR

The FB_SR function block realizes a Set/Reset function. A logic 1 at the bSafeSet input and logic 0 at the bSafeReset input leads to a logic 1 at the output. A logic 0 at the bSafeSet input and logic 1 at the bSafeReset input leads to a logic 0 at the output. If both inputs are at logic 1, the Set signal is dominant and leads to a logic 1 at the output. If both inputs are at logic 0, the output remains in its current state.

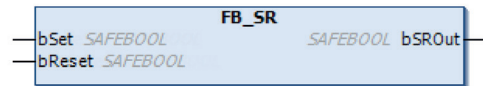

FB_TOF

A switch-off delay is realized with the FB_TOF function block. A logic 1 at the bToIn input is extended by the set time and forwarded to the output. If the input is set to 1 again before the switch-off delay time is reached, the output remains switched on. The error output is inactive, since the block does not set errors.



FB_TON

A switch-on delay is realized with the FB_TON function block. A logic 1 at the bTonIn input is extended by the set time and forwarded to the output. If the input is set to 0 again before the delay time is reached, the output is not switched on. The error output is inactive, since the block does not set errors.



FB_TWOHAND

The FB_TWOHAND block implements a two-hand circuit in which both input groups must be actuated at the same time in order to switch the output. Renewed setting of the output is only possible if both input groups are at logic 0 at the same time.





NUMDrive X Standard Functions

Motor Type and Control Method

NUMDrive X accommodates open- and closed-loop control of different motor types:

- Closed loop with current vector control: synchronous rotary motors
- Closed loop with current vector control: synchronous torque and linear motors (optional for Bi-Axes drives, High Performance version is needed: MDLUX---B1-C---)
- Closed loop with current vector control: asynchronous motors
- Open loop with current vector control: asynchronous motors
- Open loop in V/f mode: asynchronous motors

Motor Sensor

NUMDrive X can interoperate with different motor feedback types:

- Sick Stegmann Hiperface encoder
- Heidenhain EnDat 2.1 & EnDat 2.2 encoder
- 1 Vpp toothed wheel / encoder
- Single cable motor sensor (encoder used in SHX, SPX motors)
- Renishaw RESOLUTE™ encoder with BiSS interface
- Magnescale encoder

High Performance Control Loop

NUMDrive X features high internal resolution, a short sampling time (20 kHz) and specially developed control algorithms, which all contribute to its very wide bandwidth (optional for Bi-Axes drives, High Performance version is needed: MDLUX---B1C---). The drive's wide bandwidth ensures exceptional dynamic performance, as well as precision and stiffness at the mechanical interface of the machine.

Direct Measure Sensor (optional for Bi-Axes drives High Performance version is needed: MDLUX---B1C---)

NUMDrive X can interoperate with different direct measure sensor:

- EnDat 2.1 & EnDat 2.2 encoder / linear scale
- Hall sensors
- 1 Vpp encoder / linear scale (also with coded references)
- Renishaw RESOLUTE™ encoder with BiSS interface
- Magnescale encoder

EPS: Electrical Position Synchronization

To drive synchronous motors correctly, the relative position of the rotor (or magnet plates for linear motors) has to be known; this is typically realized by using and configuring absolute encoders (single or multi-turn). The EPS function allows incremental encoders to be used for this purpose; detection of the rotor (or magnet plates for linear motors) position is realized at each power on.

Spindle-Axis Commutation, Star/Delta Commutation on the Fly

NUMDrive X manages synchronous and asynchronous motors either as axis feed or as spindle feed. Furthermore, each axis can become a spindle and vice versa. For each operation mode a dedicated parameter set is defined in order to optimize the motor working conditions and the sensor configuration.

For asynchronous motors, NUMDrive X supports on-the-fly star/delta commutation.

AP01: Absolute Position with Motor's Multi-Turn Encoder and Incremental Direct Measure Sensor

The AP01 function allows the absolute position of an axis to be obtained from its motor's multi-turn encoder; the incremental direct measure sensor is initialized during initialization of the CNC-drive system.

The CNC won't require the homing on the axis even if the direct measure sensor is not absolute.

AP02: Rotary Axes with Mechanical Ratio Different from 2ⁿ

The AP02 function provides absolute position management (without the need to perform the HOMING procedure), even in the case of rotary axes with a mechanical ratio between the motor sensor (or direct measure sensor) and the load which is not 2ⁿ. The function also allows machine lengths that exceed the maximum number of encoder revolutions to be managed as an absolute axis.

AP06: Coherence Control between Motor and Direct Measure Sensor

The AP06 function controls the coherence between a motor and its direct measure sensor; its parameters define the maximum accepted displacement and the minimum time for which the displacement is accepted.

Digital Filters

Various digital filters are available, which can be freely set and cascaded to act at different points in the control loop. Types include first or second order low/high pass and notch filters, which can be applied to any combination of torque reference, speed reference and/or speed feedback.

AP12: Active Damping

As well as digital filters which can be used to dump mechanical resonances, the active damping function is a complex closed loop algorithm particularly suitable for smoothing low frequency vibrations (below 150 Hz).

NUMDrive X Optional Functions

AP03 FXSO100453: Anti-Backlash Function

Rack and pinion kinematic solutions usually have an unacceptable backlash; mechanical solutions to reduce backlash exist, but they decrease the efficiency of the transmission significantly, and deteriorate over time due to wear. The NUMDrive X anti-backlash function provides a better approach, in which gear pinions are driven by two motors preloaded to compensate for the backlash. The function can be used for linear or rotary axes driven by synchronous or asynchronous motor. For proper functionality, the mechanical drive train from motor shaft to rack should be $\geq 80\%$ efficient.

For implementing the anti-backlash function the following is needed:

- NCK Option FXSO100453
- A Bi-Axes drive in High Performance version is needed: MDLUX---B1C----
- Two Mono-Axis drives with dedicated version: MDLUX---A1D----

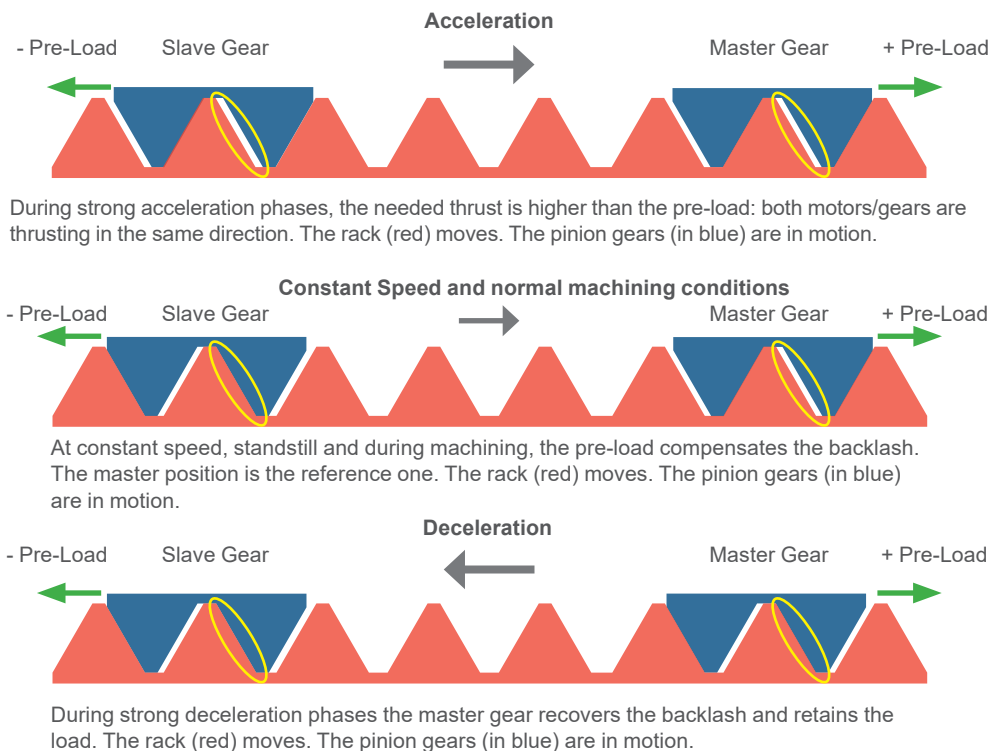

AP04 FXSO100453: Torque Duplication

Similar to the anti-backlash function, this allows two or more drives/motors to be electronically connected so that the torque/force supplied to the rack is the sum up of all motor forces.

- NCK Option FXSO100453
- A Bi-Axes drive in High Performance version is needed: MDLUX---B1C--- (Limited to a couple of motors)
- Two or three or four Mono-Axis drives with dedicated version: MDLUX---A1D--- (The drives and the motor must be of the same size, one master and till three slaves are allowed)

AP05 FXSO100454: Winding Duplication

Some specialized applications demand very high power motors (>>100 kW), with their windings divided into N independent sets. With NUMDrive X it's possible to drive such independent windings by using N drives; the drives are hard synchronized so that the system performance is equivalent to a motor driven by one drive only.

- NCK Option FXSO100454
- A Bi-Axes drive in High Performance version is needed: MDLUX---B1C--- (Limited to N=2)
- Two or three or four Mono-Axis drives with dedicated version: MDLUX---A1D--- (The drives must be of the same size, one master and till three slaves are allowed)

NUMDrive X Standard Safety Functions

As standard, NUMDrive X servo drives are equipped with the NUM-STO safety module. This provides the Safe Torque Off function as specified by the EN 61800-5-2. When the STO function is activated NUMDrive X will not provide the motor with any energy that could generate torque (or force in the case of a linear motor).

NUMDrive X Optional Safety Functions

The safe monitoring of axes' speed and position is carried out by NUM-SAMX safety module. NUM-SAMX interoperates by means of the EtherCAT (and FSoE) with the NUMSafe PLC and I/Os. NUM-SAMX is a hardware option of NUMDrive X; please refer to chapter 8 for part number definition. NUM-SAMX performs the following safety functions:

Safe Torque Off (STO)

Like NUM-STO, NUM-SAMX provides the STO function but in this case the activation of the function is performed by means of the NUMSafe PLC and FSoE. When the STO function is activated NUMDrive X will not provide the motor with any energy that could generate torque (or force in the case of a linear motor).

Safe Operational Stop (SOS)

The SOS function prevents the motor from deviating more than a defined amount from the stopped position. The NUMDrive X provides energy to the motor to enable it to resist external forces.

Safe Stop 1 (SS1)

The SS1 function monitors the motor deceleration rate within set limits to stop the motor and initiates the STO function when the motor speed is below a specified limit.

Safe Stop 2 (SS2)

The SS2 function monitors the motor deceleration rate within set limits to stop the motor and initiates the safe operating stop function when the motor speed is below a specified limit.

Safe Limited Speed (SLS)

The SLS function prevents the motor from exceeding specified speed limit(s).

Safe Limited Position (SLP)

The SLP function prevents the axes from exceeding specified position limit(s).

Safe Direction Monitoring (SDM)

The SDI function prevents the motor shaft from moving in an unintended direction.

Safe Interlock Signal

NUM-SAMX provides a safe signal to indicate whether the motor speed is below a specified limit.

Safe CAMs (SCA)

The SCA function provides a safe output signal to indicate whether the motor shaft position is within a specified range.



Flexium+ Main Component Summary

	Flexium+ Main Component Summary
PC Panel with PLC Function	FS154i or FS194i with RTS, real time system FS153 or FS194L + Industrial Box PC
Machine Panel ³	MP04 (FXHE558xxx) ¹ MP05 (FXHE03NBE1HN000) MP06 (FXHE02xxxxxxxxxx) MP08 (FXHE01xxxxxxxxxx)
Portable Handwheel ³	HBA (FXHE181xxx)
NCK	Flexium NCK ²
I/Os System	NUMEtherCAT gateway and terminals (CTMG1100 + CTMTxxxx)
Safe PLC and Safe I/Os ³	NUMSafe PLC and terminals (CTMP6900, CTMP1960-2600, CTMS1904, CTMS2904, CTMS2912)
Safe Motion Functions	NUMDrive X with NUM-SAMX option (MDLUXxxxx1xFN0x)
Digital CNC Servo Drives	NUMDrive X (MDLUXxxxx1xxN0x)
Digital PLC Servo Drives (CANopen)	NUMDrive C (MDLU3xxxxCxxN0x) ¹
Servomotors	SHXxxxx SPXxxxx BHXxxxx BPXxxxx BPHxxxx BPGxxxx BHLxxxx
Spindle Motors	AMSxxxx IMxxxx

2

¹ CANopen card needed for FXPCxxxx and Flexium option (FXSO000430 / FXSO000432) needed too

² Base component of a Flexium system – additional units required in Multi-NCK configuration

³ Optional

Flexium+ CNC System

Flexium+ Options Grid Summary Table Basic Features and Optional Extensions



Basic Features and Optional Extensions

	Flexium+ 6	Flexium+ 8	Flexium+ 68
Axes + Spindle (digital and analog)			
Base	5 ¹	5 ²	5
Optional max	-	-	6 to 32
Interpolated Axes per Channel			
Base	4	4	4
Optional max	-	-	9
Channels			
Base	1	1	1
Optional max	-	2	8
Handwheels			
Base	0	0	0
Optional max	2	2	4
CANopen Interfaces			
Base	0	0	1
Optional max	1	2	2

¹ up to 4 axes and 1 spindle

² up to 5 axes or 4 axes and 1 spindle



Machine Configuration

	Reference	Flexium+ 6	Flexium+ 8	Flexium+ 68
Platforms				
Flexium+ 6	FXP1101100	●	-	-
Flexium+ 8	FXP1101150	-	●	-
Flexium+ 68	FXP2101200	-	-	●
Configuration²				
Turning	FXSO200060	○	○	○
Milling	FXSO200061	○	○	○
NCK Special Functions				
Multi-NCK	FXSW282117	-	-	○
NCK Digital Twin	FXPA000599	○	○	○
Axes, Spindles or Measure inputs³				
6 th axis/spindle	FXSO100006	-	-	○
7 th + 8 th axis/spindle	FXSO100008	-	-	○
9 th up to 12 th axis/spindle	FXSO100012	-	-	○
13 th up to 16 th axis/spindle	FXSO100016	-	-	○
17 th up to 32 nd axis/spindle	FXSO100032	-	-	○
Analog interface 1 for axis or spindle	FXSO100373	○	○	○
Analog interface 2 for axis or spindle	FXSO100374	○	○	○
Handwheels⁴				
1 st Handwheel	FXSO100375	○	○	○
2 nd Handwheel	FXSO100376	○	○	○
3 rd Handwheel	FXSO100377	-	-	○
4 th Handwheel	FXSO100378	-	-	○
Interpolation capability				
5 th interpolated axis ¹	FXSO100335	-	-	○
6 th interpolated axis ¹	FXSO100336	-	-	○
7 th interpolated axis ¹	FXSO100337	-	-	○
8 th interpolated axis ¹	FXSO100338	-	-	○
9 th interpolated axis ¹	FXSO100339	-	-	○
Channels				
2 nd channel	FXSO100392	-	○	○
3 rd + 4 th channel	FXSO100394	-	-	○
5 th + 6 th channel	FXSO100396	-	-	○
7 th + 8 th channel	FXSO100398	-	-	○

¹ Subject to international export control

² The choice must be specified with the order

³ Each axis, spindle or position measuring system counts as a device used to calculate the necessary option

⁴ Handwheels are either connected on an analog interface or as a CANOpen device. Also when connected to an analog interface, the handwheel is not counted to the axes, spindles or position measurement inputs

● Standard ○ Optional - Not Available



Axes, Spindle and Machining Functions

	Reference	Flexium+ 6	Flexium+ 8	Flexium+ 68
Axes functions				
Duplicated and synchronized axes	FXSO000266	-	○	○
Inclined or tilted axes	FXSO000315	-	○	○
Conversion Cartesian to polar/cylindric	FXSO000340	-	○	○
Tool vector programming/3DWPC (G32/G34) ⁹	FXSO000402	-	○	○
NURBS (B-Spline) interpolation ²	FXSO000426	-	-	○
DEMX (Drive Embedded Macro) ¹	FXSO000456	-	○	○
Local contour rounding function (G164) ⁸	FXSO000461	-	○	○
Linear feed variation (G94 EF1)	FXSO000462	○	○	○
Brake test	FXSO000463	○	○	○
Multi-turn encoder emulation	FXSO000464	-	○	○
Technological Feed Adaptation (TFA)	FXSO000466	○	○	○
Automatic Offset Compensation (AOC)	FXSO000467	○	○	○
Circular interpolation by three points	FXSO000497	-	○	○
Smooth polynomial interpolation ³	FXSO000499	-	○	○
Radial axis boring / milling function (U-axis)	FXSO000514	-	○	○
Spline Interpolation (G06, G48, G49)	FXSO000518	-	○	○
Programmable precision ¹	FXSO000519	-	○	○
Multi-level Electronic Gear Box (MLEGB) ^{1,5}	FXSO000699	-	○	○
Tandem function	FXSO100453	-	○	○
Winding duplication	FXSO100454	-	○	○
Spline Interpolation with Curve Smoothing (G104)	FXSO181706	-	○	○
Adaptive Feed Control	FXSW282126	-	○	○
Spindle functions				
Spindle synchronization	FXSO000156	-	○	○
Sequenced thread cutting (G31/G38)	FXSO000331	-	○	○
Rigid Tapping	FXSO000332	-	○	○
Machining functions				
Rotation Tool Center Point (G26 RTCP)	FXSO000154	-	○	○
High Speed Cutting (HSC)	FXSO000155	-	○	○
Tilted Nozzle Management (TNM) ⁹	FXSO000404	-	○	○
Advanced contour offset (C.OFF)	FXSO000465	-	○	○
Combined machine (turning + milling) ⁴	FXSO000581	-	-	○
Fast Gear Alignment (FGA)	FXSO000595	-	○	○
NUMgrind GC Cycles	FXSO000681	○	○	○
NUMgrind Cyl. + Non-Circ. Grinding Cycles	FXSO000682	-	○	○
Milling and standard pocket cycles ⁶	FXSO000695	-	-	○
Turning cycles ⁷	FXSO000696	-	○	○
Trochoidal Milling Cycle (G725)	FXSO000700	-	○	○
Engraving Cycle (G730)	FXSO000701	○	○	○
Inclined plane machining	FXSO000914	-	-	○
Polygon-cutting cycles	FXSO100538	-	-	○
NUMcoss	FXSW282125	○	-	○

¹ Subject to international export control

² Includes FXSO000499, FXSO000518

³ Includes FXSO000518

⁴ Includes FXSO000331, FXSO000340, FXSO000514, FXSO000696, FXSO200060, FXSO200061

⁵ Includes FXSO000082

⁶ Includes FXSO200061

⁷ Includes FXSO200060

⁸ Needs FXSO000499

⁹ Needs FXSO000154

Common features for all systems:

- Linear and circular interpolation
- Helical interpolation in milling systems
- Axis and Inter-axes calibration
- Jerk-controlled acceleration
- Anti-pitch correction
- Spindle indexing
- Spindle range automatic search
- Tangential control (G748)



CNC Programming, Tools and Operation

2

	Reference	Flexium+ 6	Flexium+ 8	Flexium+ 68
Programming functions				
Dynamic operators in C ^{1,2}	FXSO000249	-	○	○
Dynamic operators ¹	FXSO000250	-	○	○
Early Block Change (G777 EBC)	FXSO000500	-	-	○
Scaling factor (G74)	FXSO000506	-	○	○
Angular program offset (ED)	FXSO000507	-	○	○
File handling in NC memory (G76)	FXSO000511	-	○	○
On the fly measurement / probing (G10)	FXSO000520	-	○	○
Structured and symbolic programming	FXSO000535	-	○	○
Building a profile table ³	FXSO000536	-	○	○
Tools functions				
3D tool radius correction (G29)	FXSO000400	-	○	○
Extension to 255 offsets	FXSO000401	-	○	○
3D tool radius correction in RTCP (G43)	FXSO000411	-	-	○
Tool management	FXSW282119	○	○	○
Machine operations				
N/M Auto	FXSO000082	-	○	○
Emergency retract (G75)	FXSO000505	-	○	○
Backtrack along stored path	FXSO000523	-	○	○
Compensations				
VEComp 3-/4-axes ¹	FXSO000458	○	○	○
VEComp 5-axes ¹	FXSO000459	○	○	○
VEComp rotary axes ¹	FXSO000460	-	-	○
Measuring functions				
Kinematic measurement cycle ⁴	FXSO000153	-	-	○
Probing cycles for turning	FXSO100590	-	○	○
Probing cycles for milling	FXSO100591	-	○	○

¹ Subject to international export control

² Includes FXSO000250

³ Includes FXSO000535

⁴ Requires FXPA000560

Common features for all systems:

- Parametric programming
- Profile Geometric Programming
- Inch / Metric conversion
- 32 Tool offsets
- Radius and length compensation
- Tool wear offset by the PLC
- Tool axis selection

● Standard ○ Optional - Not Available



PLC Functions

	Reference	Flexium+ 6	Flexium+ 8	Flexium+ 68
First CAN Interface	FXSO000430	○	○	●
Second CAN interface	FXSO000432	-	○	○
Multi-NCK	FXSW282117	-	-	○
Extended NCK access	FXSW282124	○	○	○
PLC Visualization ¹	FXSW282160	○	○	○
Target visualization ³	FXSW282302	○	○	○
Web Visualization	FXSW282303	○	○	○
EtherCAT Safe PLC	FXSW282305	○	○	○
EtherCAT Profibus Master CTMT6731	FXSW282306	○	○	○
EtherCAT IO-Link Master CTMT6224	FXSW282312	○	○	○
CODESYS HMI SL ²	FXSW282500	○	○	○

¹ PLC Visualization allows for integrating PLC controlled pages in a frame of Flexium+ HMI

² USB dongle mandatory (FXHE557400)

³ Target visualization: PLC controlled visualization displayed on the same device than the one running the PLC. Contrary to the PLC visualization the screen are distinct from Flexium HMI

● Standard ○ Optional - Not Available



Applications

The following table lists applications that were developed for a special purpose and could be tailored to suit new applications. Please consult us for detailed information.

	Reference	Flexium+ 6	Flexium+ 8	Flexium+ 68
Adaptive feed control	FXSW282126	○	○	○
Waterjet: feed control (G120)	FXSW283001	○	○	○
Gap control	FXSW283004	○	○	○
Kinematics transformation for NUMcut head	FXSW283005	-	-	○
Parameter exchange in CNC/drives by PLC	FXSW283007	○	○	○
Spindle axis synchronization by NCK	FXSW283008	○	○	○

2

● Standard ○ Optional - Not Available

Flexium+ CNC System

Flexium+ Options Grid Summary Table

HMI Functions/Flexium 3D/NUMmonitor/NUMconnect/Flexium Tools

HMI Functions

	Reference	Flexium+ 6	Flexium+ 8	Flexium+ 68
HMI Features				
Symbolic names	FXSW282112	○	○	○
Extended tool table	FXSW282113	○	○	○
Teach-in	FXSW282114	○	○	○
NUMtransferCNC	FXSW282200	○	○	○
NUMtransferCNC (Multi-CNC)	FXSW282201	-	-	○
Visualization				
PLC Visualization	FXSW282160	○	○	○
CODESYS Option: HMI classic	FXSW282300	○	○	○
CODESYS Option: Target Visualization	FXSW282302	○	○	○
CODESYS Option: WEB Visualization	FXSW282303	○	○	○
Technology HMI				
Flexium CAM engine	FXSW282180	-	○	○
NUMgear HMI Hobbing ¹	FXSW282220	-	○	○
NUMgear HMI Threaded Wheel Grinding (TWG) ¹	FXSW282221	-	○	○
NUMgear HMI Shaping ¹	FXSW282222	-	○	○
NUMmill HMI ¹	FXSW282223	○	○	○
NUMgrind HMI GC ¹	FXSW282231	-	○	○
NUMgrind HMI Cyl. + Non-Circ. Grinding ¹	FXSW282232	-	○	○
NUMcut HMI Standard	FXSW282510	○	○	○

¹ Flexium CAM engine (FXSW282180) is required

Flexium 3D Functions

	Reference	Flexium+ 6	Flexium+ 8	Flexium+ 68
3D Simulation with online collision detection	FXSO000521	○	○	○
3D Simulation with material removal	FXSW282153	○	○	○
3D Simulation with collision detection	FXSW282154	○	○	○
Online simulation	FXSW282155	○	○	○
3D Machine editor	FXSW282156	○	○	○
3D Graphical SEARCH Mode	FXSW282157	○	○	○
3D-Path Editor	FXSW282158	○	○	○

NUMmonitor Functions

	Reference	Flexium+ 6	Flexium+ 8	Flexium+ 68
NUMmonitor Basic License	FXSW282313	○	○	○
NUMmonitor Extension	FXSW282315	○	○	○

NUMconnect Functions

	Reference	Flexium+ 6	Flexium+ 8	Flexium+ 68
OPC DA		●	●	●
NUM IloTgateway	FXSW282509	○	○	○

● Standard

○ Optional

- Not Available



Option Packs - Description

For an optimal system configuration, the options are regrouped in different technology packs. The list below defines the packs and their availability according to each system.

		Reference	Flexium+ 6	Flexium+ 8	Flexium+ 68
	CNC/HMI Option Packs				
T	Turning Pack	FXPA000555	○	○	○
M0	Basic Milling Pack	FXPA000560	○	○	○
M1²	Milling Pack 1	FXPA000561	-	-	○
M2^{1,2}	Milling Pack 2	FXPA000562	-	-	○
M3^{1,2}	Milling Pack 3	FXPA000563	-	-	○
HSC²	High Speed Cutting Pack	FXPA000564	-	-	○
AM^{1,2}	Aluminum Machining Pack	FXPA000566	-	-	○
CUT²	Cutting Pack	FXPA000567	-	○	○
W1^{1,2}	Woodworking Pack	FXPA000576	-	-	○
TR¹	Tool Grinding Pack	FXPA000586	-	-	○
GS0¹	Surface Grinding Pack 0	FXPA000587	-	○	○
GC0¹	Cylindrical Grinding Pack 0	FXPA000588	-	○	○
GC1¹	Cylindrical Grinding Pack 1	FXPA000592	-	○	○
CNCG¹	Cylindrical + Non-circular Grinding Pack ¹	FXPA000593	-	○	○
GTWG¹	Threaded Wheel Grinding Pack	FXPA000589	-	○	○
GH1	Gear Hobbing Pack 1	FXPA000596	-	○	○
GH3¹	Gear Hobbing Pack 3	FXPA000598	-	○	○
GSH	Gear Shaping Pack	FXPA000590	○	○	○
	Flexium 3D Option Packs				
WJC	Flexium 3D Water Jet Cutting Package	FXSW282170	○	○	○

¹ Subject to international export control

² Pack M0 is required

● Standard ○ Optional - Not Available



CNC/HMI Option Pack Contents Part 1

	Reference	M0	M1 ²	M2 ^{1,2}	M3 ^{1,2}	HSC ²	T	W1 ^{1,2}	AM ^{1,2}	CUT ^{1,2}
Rotation Tool Center Point (G26 RTCP)	FXSO000154			■	■			■	■	■
High Speed Cutting (HSC)	FXSO000155					■		■		
Sequenced thread cutting (G31/G38)	FXSO000331						■			
Rigid Tapping	FXSO000332		■		■					
5 axis interpolation	FXSO100335			■	■			■	■	
3D tool radius correction (G29)	FXSO000400		■		■			■		
255 Tool offsets	FXSO000401	■	□	□	□	□		□	□	□
Tilted Nozzle Management (TNM)	FXSO000404									■
3D tool radius correction in RTCP (G43)	FXSO000411			■	■	■		■		
Local contour rounding function (G164)	FXSO000461					■				
Circular interpolation by three points	FXSO000497	■	□	□	□	□	■	□	□	□
Polynomial Interpolation	FXSO000499					■				
Scaling factor (G74)	FXSO000506	■	□	□	□	□	■	□	□	□
Angular program offset (ED)	FXSO000507	■	□	□	□	□	■	□	□	□
File handling in NC memory (G76)	FXSO000511	■	□	□	□	□	■	□	□	□
Spline interpolation	FXSO000518					■				
On the fly measurement / probing (G10)	FXSO000520	■	□	□	□	□	■	□	□	□
Structured and symbolic programming	FXSO000535	■	□	□	□	□	■	□	□	□
Milling cycles	FXSO000695	■	□	□	□	□		□	□	□
Turning cycles	FXSO000696						■			
Trochoidal Milling Cycle (G725)	FXSO000700		■							
Engraving Cycle (G730)	FXSO000701	■	□	□	□	□		□	□	□
Inclined plane machining	FXSO000914		■	■	■				■	

¹ Subject to international export control

² Pack M0 is required

■ option included in the pack

□ option implied by the mandatory pack (M0 or T)



CNC/HMI Option Pack Contents Part 2

	Reference	TR ¹	GH1	GH3 ¹	GTWG ¹	GSH	GC0 ¹	GC1 ¹	CNCG ¹	GS0 ¹
N/M Auto	FXSO000082								■	
Sequenced thread cutting (G31/G38)	FXSO000331				■		■	■	■	
5 axis interpolation	FXSO100335	■								
Conversion Cartesian to polar/cylindrical	FXSO000340								■	
Advanced Contour Offset (C.OFF)	FXSO000465								■	
Circular interpolation by three points	FXSO000497	■					■	■	■	■
Emergency retract (G75)	FXSO000505		■	■	■	■	■	■	■	■
Scaling factor (G74)	FXSO000506						■	■	■	■
Angular program offset (ED)	FXSO000507						■	■	■	■
File handling in NC memory (G76)	FXSO000511	■	■	■	■		■	■	■	■
Programmable precision	FXSO000519	■					■	■	■	■
On the fly measurement / probing (G10)	FXSO000520	■	■	■	■		■	■	■	■
Structured and symbolic programming	FXSO000535	■	■	■	■	■	■	■	■	■
Building a profile table	FXSO000536								■	
Spline Interpolation	FXSO000518				■					
Fast Gear Alignment (FGA)	FXSO000595				■					
NUMgrind GC Cycles	FXSO000681							■		
NUMgrind Cyl.+Non-Circ. Grinding Cycles	FXSO000682								■	
NUMgear Hobbing Cycles	FXSO000690		■	■						
NUMgear TWG Cycles	FXSO000691				■					
NUMgear Shaping Cycles	FXSO000692					■				
Milling cycles	FXSO000695									■
Turning cycles	FXSO000696						■	■	■	
Simple Electronic Gear Box	FXSO000698		■							
Multi-level Electronic Gear Box (MLEGB)	FXSO000699			■	■				■	
2 nd channel	FXSO100392						■	■	■	■
Spline Interpolation with Curve Smoothing (G104)	FXSO181706				■					
Flexium CAM engine	FXSW282180		■	■	■	■		■	■	
NUMgear HMI Hobbing	FXSW282220		■	■						
NUMgear HMI Threaded Wheel Grinding (TWG)	FXSW282221				■					
NUMgear HMI Shaping	FXSW282222					■				
NUMgrind HMI GC	FXSW282231							■		
NUMgrind HMI Cyl. + Non-Circ. Grinding	FXSW282232								■	

Flexium 3D Option Pack Contents

	Reference	WJC
3D Simulation material removal	FXSW282153	■
Online Simulation	FXSW282155	■
Graphical SEARCH mode	FXSW282157	■

¹ Subject to international export control

■ option included in the pack

□ option implied by the mandatory pack (M0 or T)



NUMDrive X Functions

		Bi-Axes SP	Mono-Axis HP	Bi-Axes HP
Interface	High speed digital bus DISC NT+	●	●	●
Control Performance	Standard performance control loops	●	●	●
	High performance control loops	-	●	●
Compatible Motors	Closed loop: synchronous rotary motors	● ¹	●	●
	Closed loop: synchronous torque and linear motors	-	●	●
	Closed loop: asynchronous motors	●	●	●
	Open loop: asynchronous motors (V/F mode)	●	●	●
Compatible Motor Sensor	Single cable motor encoder (SHX, SPX motors)	●	●	●
	EnDat 2.1 & EnDat 2.2 encoder	●	●	●
	1 Vpp toothed wheel / encoder	●	●	●
	Renishaw RESOLUTE™ encoders with BiSS interface	●	●	●
	Magnescale encoders	●	●	●
Compatible Direct Measure Sensors	EnDat 2.1 & EnDat 2.2 encoder / linear scale	-	●	●
	Hall sensors	-	●	●
	1 Vpp encoder / linear scale (also with coded references)	-	●	●
	Renishaw RESOLUTE™ encoder with BiSS interface	-	●	●
Special Functions	Spindle operation for synchronous and asynchronous motors	●	●	●
	Synchronous motor phasing without movement	●	●	●
	Spindle-Axis commutation	-	●	●
	Star/Delta commutation on the fly (for asynchronous motor)	-	●	●
	Rotary axis with mechanical ratio not 2 ⁿ	●	●	●
	AP03: Anti-backlash function	-	○	○
	AP04: Torque duplication	-	○	○
	AP05: Winding duplication	-	○	○
	DEMX: Drive Embedded Macro ²	-	○	○
	Coherence control between motor and direct measure sensor	-	●	●
Various active damping functions	-	●	●	
Various freely settable filters	●	●	●	
EPS: Electrical Position Synchronization	-	●	●	
AP01: Absolute position with motor's multi-turn encoder and incremental direct measure sensor	-	●	●	

¹ for standard performance, max. 5 pole pairs motors

² Subject to international export control

● Standard ○ Optional - Not Available



NUMDrive X Functions

		Bi-Axes SP	Mono-Axis HP	Bi-Axes HP
Safety Functions compliant with EN 61800-5-2	NUM-STO module with Safe Torque Off	○	○	○
	NUM-SAMX module with <ul style="list-style-type: none"> • STO Safe Torque Off • SLS Safely Limited Speed • SOS Safe Operational Stop • SS1 Safe Stop 1 • SS2 Safe Stop 2 • SLP Safe Limited Position • SDM Safe Direction Monitoring • SCA Safe CAMs 	○	○	○

2

● Standard ○ Optional - Not Available



FS194i Operator Panels with Integrated iPC

With the latest 19-inch projected capacitive touch screen system, NUM has set a new standard for operating panels in the machine tool industry. A compact and scalable panel PC with Intel's i5 allows entry to multi-processor technology with Windows 10 operating system.

The FS194i operator panel provides a durable, modern front end for machine control. It has an IP65 degree of protection at the front, and IP20 at the rear. High-quality 4 mm hardened safety glass protects the front, without introducing any disturbing reflections.

A narrow brushed aluminum frame with rounded edges provides complete side protection for the glass and multi-touch sensor.



FS194i Virtual Keyboards

The Flexium+ HMI, in conjunction with the FS194i operator panel, offers three virtual keyboards which provide reliable and cost-effective alternatives to their physical counterparts.

Virtual QWERTY Keyboard

Available in 5 languages, the virtual QWERTY keyboard implements a complete set of standard alphanumeric, function and scroll keys.

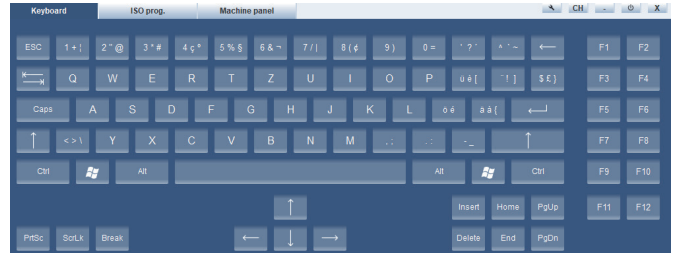

Virtual ISO Programming Keyboard

This dedicated virtual ISO programming keyboard provides users with fast access to common ISO commands. The layout and functions of the keys can be easily customized by the user.

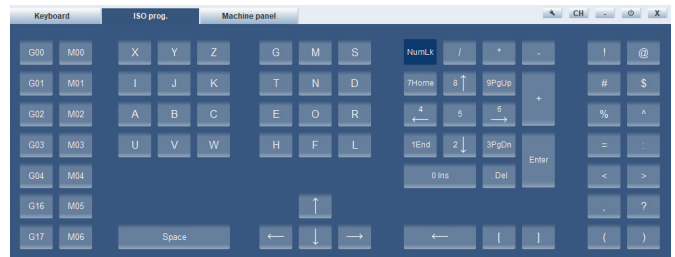

Virtual Machine Panel

Available as an option, this soft-key version of a complete machine panel eliminates the need for a physical machine panel such as the MP04, helping to reduce system costs significantly.

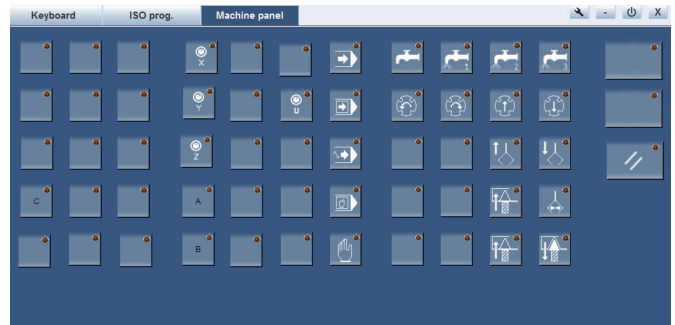



FS194i (with Integrated iPC) Technical Characteristics

FXPC194CN2SxR20		
Screen	User interface options	Projected capacitive touch screen with hardened glass protection
	Technology	19" TFT LCD (16.9 million colours)
	Resolution	1024 x 1280 from 60 Hz to 75 Hz (vertical orientation)
	Size	304 x 379 mm
	Backlight	LED, Contr. 400:1 (Type)
Main PC Features	CPU	i5-6500TE 2.3GHz Quad Core 6th generation
	RAM	8 GB
	Mass storage	SSD 64 GB
	Operating system	Windows 10 IoT Enterprise LTSB 64 bits
Communication Interfaces	Ethernet (ETH)	3 x Gigabit LAN / RTE
	USB	2 x USB 2.0 Type A / 4 x USB 3.0 Type A
	Serial interface	2 x COM
	Dual CAN + NVRAM	optional
	DVI-D	1
	CRT monitor	No
	HDMI	1
Power Supply	Rated voltage	24VDC (+15%/-15%) SELV
	Protection against reverse polarity	Yes
	Protection against over voltage	Yes
	Potential isolation	No. (The 0V-pin of the PS is connected to the digital GND)
	Power consumption	70 W, max. 120 W (5A)
Ambient Conditions	Climatic conditions operation	5..45°C, 70% rel. air humidity, non-condensing
	Climatic storage conditions	-20...60°C, 70% rel. air humidity, non-condensing
	Climatic conditions transport	-20...60°C, 90% rel. air humidity, non-condensing
Degree of Protection	Front	IP 65
	Rear	IP 20
Weight		9.8 kg
Dimensions	W x H x D	394 x 490 x 92 mm
Fan	Type	With fan

FS194i (with Integrated iPC) Outlines

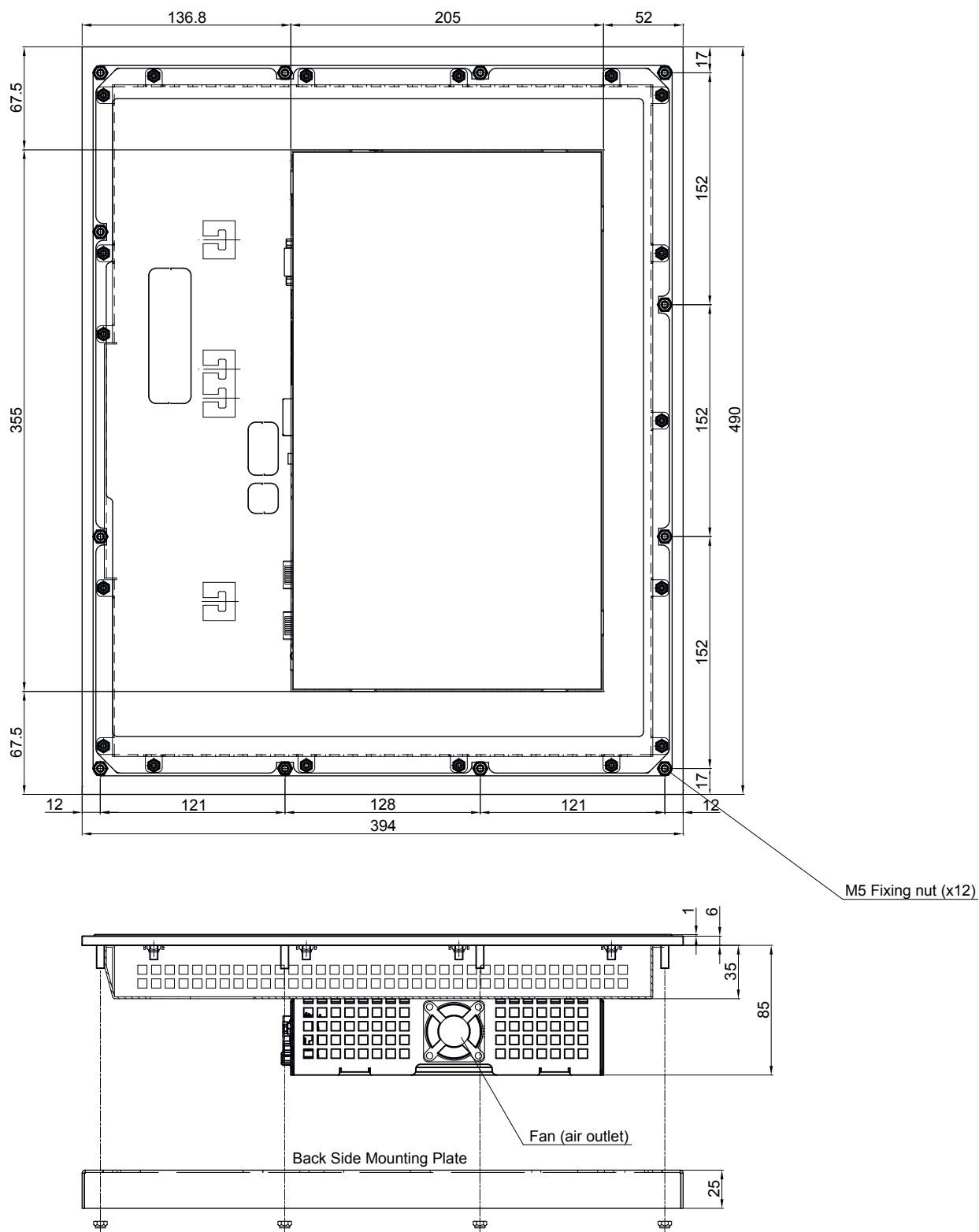

FS194i (with Integrated iPC) Cut-Out and Hole Patterns

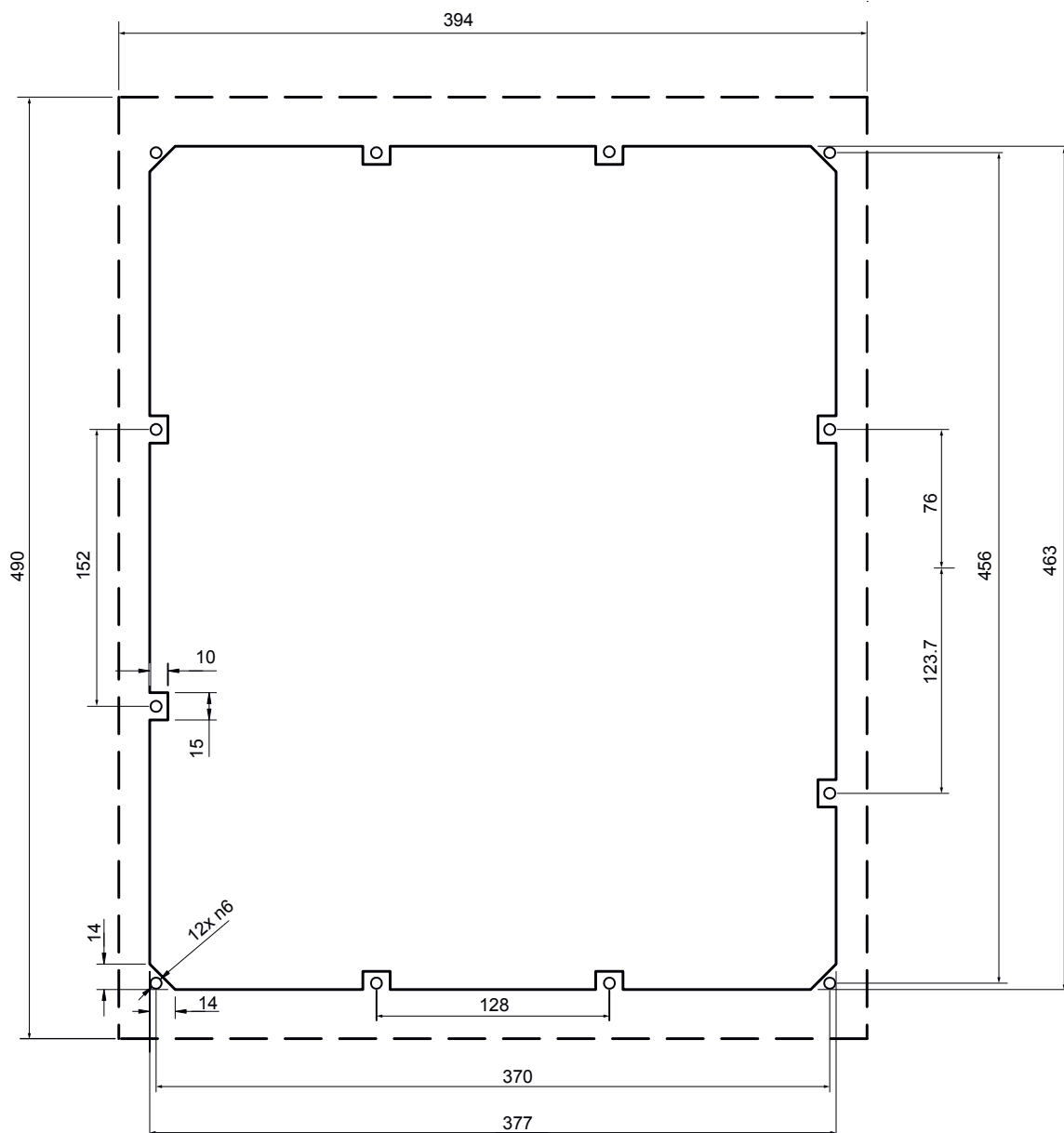



FS194i (with Integrated iPC) Cut-Out when using Back Side Mounting Plate

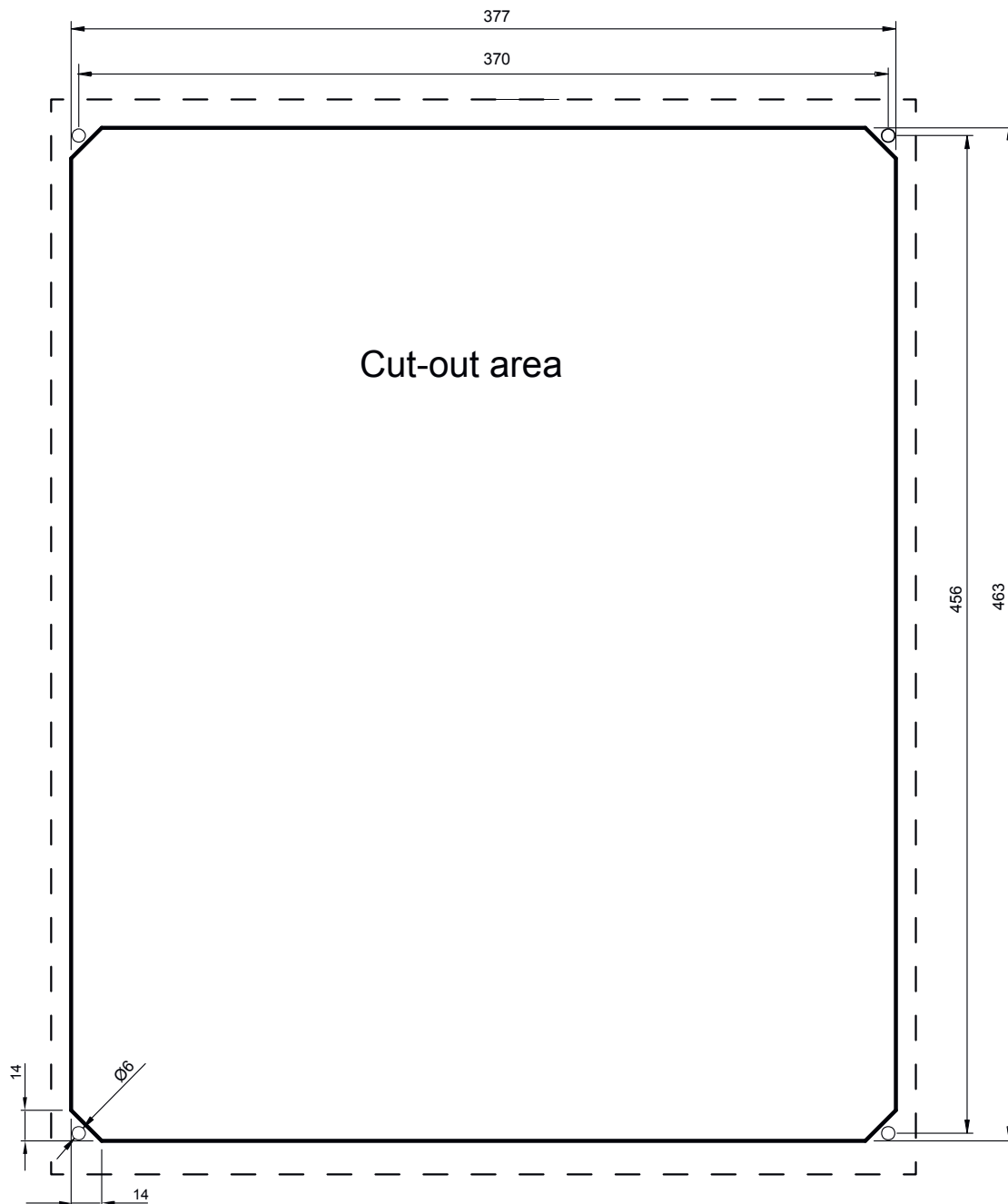

Cut-out in case of using back side mounting plate.

Operator Panels and Industrial PC

FS194i Operator Panels with Integrated iPC

Ordering Codes

Operator Panel FS194i Available Versions

FS194i Version	Ordering Codes
FS194i-TS P2 SSD RT	FXPC194CN2SNR20
FS194i-TS P2 SSD RT CAN NVRAM	FXPC194CN2SDR20

	FXPC	19	4	C	N	2	S	D	R	2	0
Display Unit • LCD 19"		19									
Panel/Mechanical Variant • Fourth generation			4								
Display Sensor • Touch screen (proj.) capacitive				C							
Keyboard Type • No keyboard, no function keys					N						
IPC Mother Board, Processor • Performance level P2						2					
Mass Memory Type • SSD (Solid State Disk)							S				
Option Board • No fieldbus • CAN + NVRAM								N D			
Flexium RTS • Real time									R		
Operating System • Windows 10 kernel										2	
Spare Number											0

3

FS154i Operator Panels with Integrated iPC

FS154i Operator Panels with Integrated iPC

FS154i PC panels provide a powerful and ergonomic platform for the Flexium+ HMI, enabling you to interact with the machine in a simple and logical manner. The integrated PCs use modern quad-core processors.

Two performance levels are available: P1 and P2 (see page 106 for details).

Depending on the application, you can choose the user interface:

- With 22 large function keys (keyboard option F)
- With 22 large function keys and an expanded QWERTY keyboard (keyboard option Q)
- Touch screen available as option

The display quality of their 15.1" screen makes the panels very legible even in poorly-lit environments. Compact and very rugged, the panels are sealed (IP65) and suitable for use in severe industrial environments.

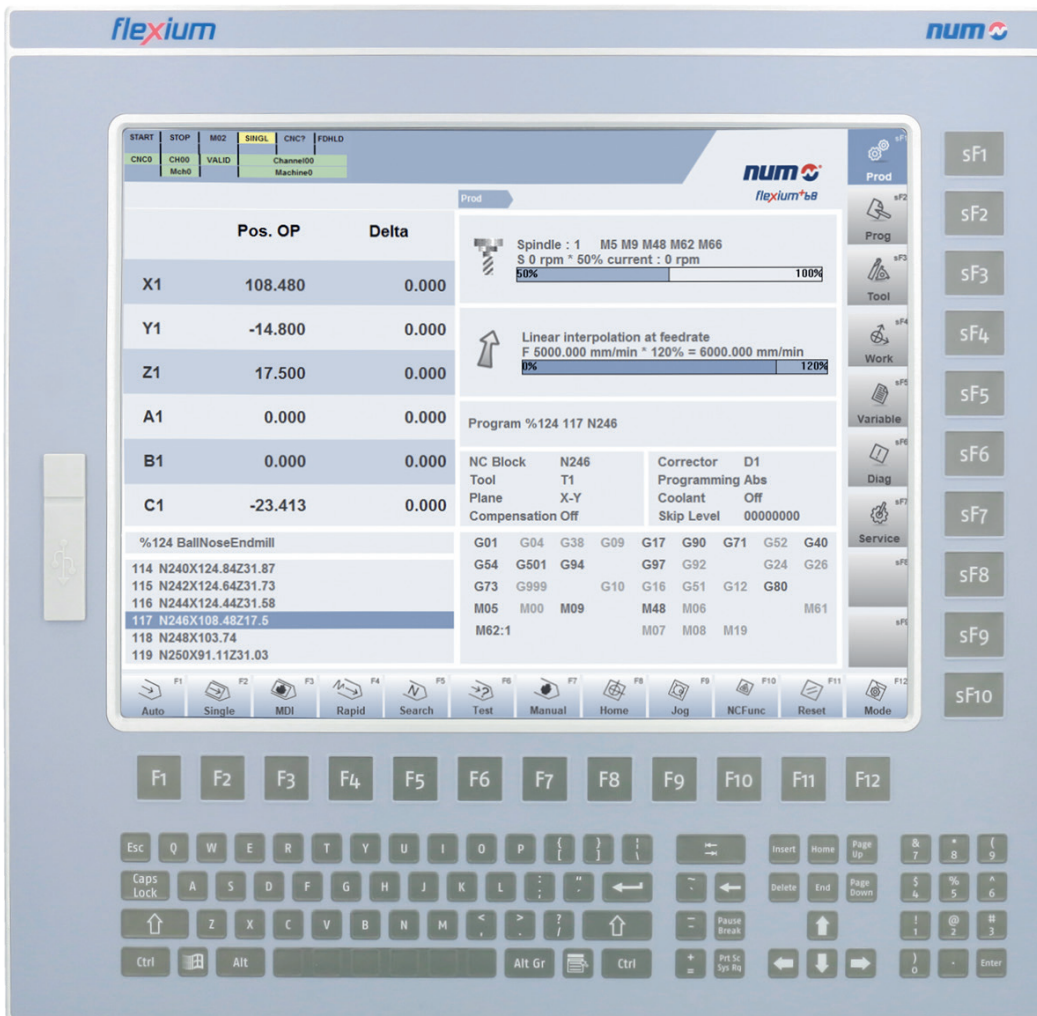

FS154i Operator Panels Interface Options

3



Panel with 22 Function Keys
Reference with PC Panel coding "F"

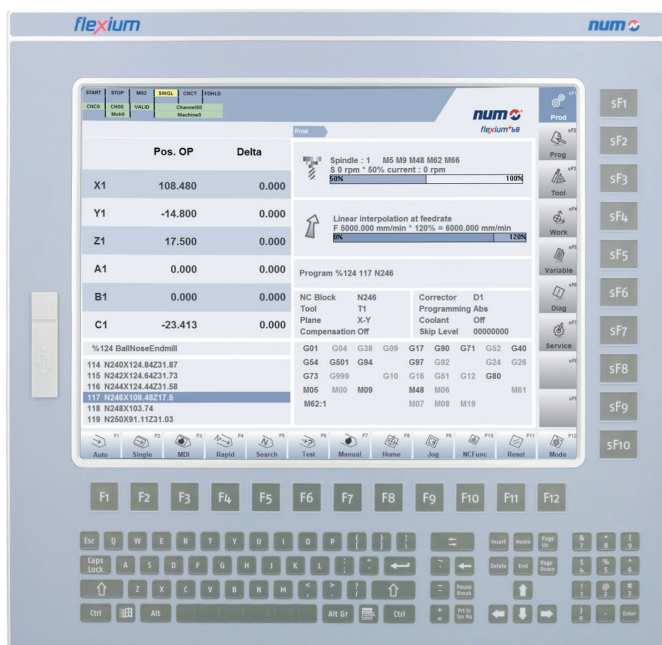

Panel with 22 Function Keys and QWERTY-Keyboard
Reference with PC Panel coding "Q"

Operator Panels and Industrial PC

FS154i Operator Panels with Integrated iPC

Technical Characteristics

FS154i Operator Panel with integrated iPC

		FXPC154xx1HxR10 (FS154 P1)	FXPC154xx2HxR20 (FS154 P2)
Screen	User interface options	Active panel with integrated PC with: <ul style="list-style-type: none"> • 22 Function Keys • 22 Function Keys and Qwerty Keyboard • Touch Screen (resistive) 	
	Technology	15" TFT LCD (16.9 million colors)	
	Resolution	1024 x 768 from 60Hz to 75Hz	
	Size	304 x 228 mm (12 x 9 inch)	
	Backlight	LED, Contr. 700:1 (Type)	
Main PC Features	CPU	Intel® Celeron™ CPU J1900 @ 2GHz Quad Core	Intel® i5-6500TE 2.3GHz Quad Core 6th generation
	RAM	2 GB	8 GB
	Mass storage	250 GB Hard Disk	SSD 64 GB
	Operating system	Win. Embedded 8 .1 Industry Pro	Windows 10 IoT Enterprise LTSP 64 bits
Communication Interfaces	Ethernet (ETH)	3 x Gigabit LAN / RTE	
	USB front	1 x USB 2.0 Type A	
	USB rear	1 x USB 3.0 Type A / 3 x USB 2.0 Type A	2 x USB 2.0 Type A / 4 x USB 3.0 Type A
	Serial interface	2 x COM	
	Dual CAN + NVRAM	optional	
	DVI	Yes	
	CRT monitor	No	
Power Supply	HDMI	No	Yes
	Rated voltage	24 VDC (+15%/-15%) SELV	
	Protection against reverse polarity	Yes	
	Protection against over voltage	Yes	
	Potential insulation	No, the 0V pin is connected to the digital GND	
Ambient Conditions	Power consumption	typ. 25 W max. 50 W (2.1A)	typ. 48 W max. 96 W (4A)
	Climatic conditions operation	0..45°C, 70% rel. air humidity, non-condensing	
	Climatic storage conditions	-20...60°C, 70% rel. air humidity, non-condensing	
Degree of Protection	Climatic conditions transport	-20...60°C, 90% rel. air humidity, non-condensing	
	Front	IP 65	
	Rear	IP 20	
Weight	Pollution degree	2	
		ca. 6.1 kg Function Key version ca. 6.5 kg Full Qwerty version	
Dimensions	W x H x D	410 x 330 (400) x 72.3mm	
Fan	Type	Fan-less	With fan

FS154i Outline Dimensions (dashed lines FQ version)

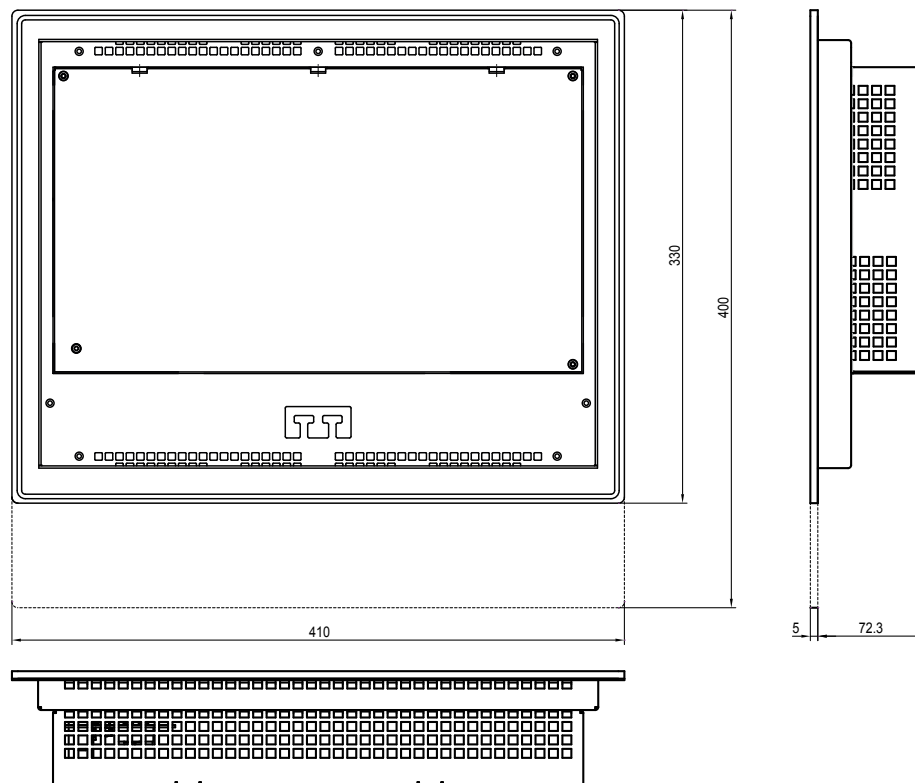

3

Dashed line FS154xQ version only.

FS154i Cut-Out

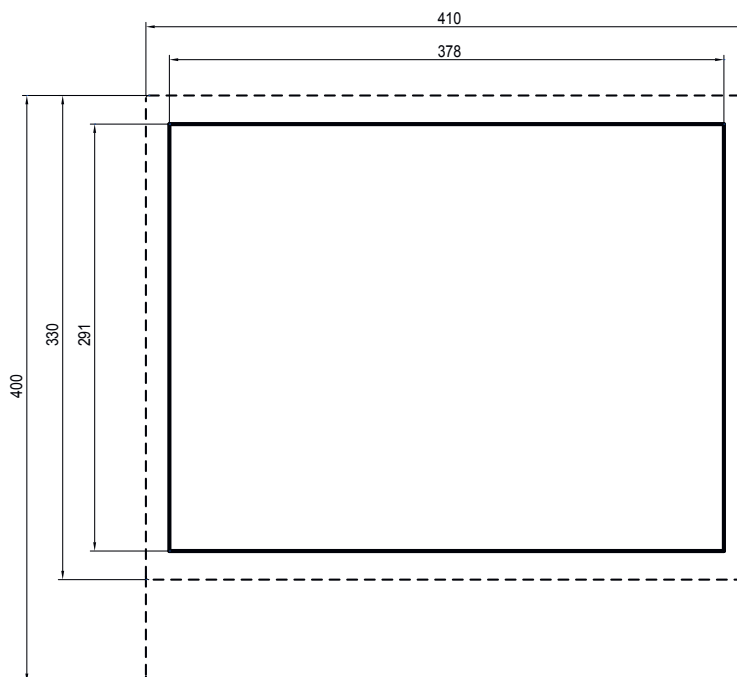

Dashed lines shows the panel dimensions.

Operator Panels and Industrial PC

FS154i Operator Panels with Integrated iPC

Ordering Codes

Operator Panel FS154i Available Versions

FS154i Version	Ordering Codes
FS154i-FK P1 HD RT	FXPC154NF1HNR10
FS154i-FQ P1 HD RT	FXPC154NQ1HNR10
FS154i-FK P1 HD RT CAN NVRAM	FXPC154NF1HDR10
FS154i-FQ P1 HD RT CAN NVRAM	FXPC154NQ1HDR10
FS154i-FK TS P1 HD RT	FXPC154RF1HNR10
FS154i-FQ TS P1 HD RT	FXPC154RQ1HNR10
FS154i-FK TS P1 HD RT CAN NVRAM	FXPC154RF1HDR10
FS154i-FQ TS P1 HD RT CAN NVRAM	FXPC154RQ1HDR10
FS154i-FK P2 SSD RT	FXPC154NF2SNR20
FS154i-FQ P2 SSD RT	FXPC154NQ2SNR20
FS154i-FK TS P2 SSD RT	FXPC154RF2SNR20
FS154i-FQ TS P2 SSD RT	FXPC154RQ2SNR20
FS154i-FK P2 SSD RT CAN NVRAM	FXPC154NF2SDR20
FS154i-FQ P2 SSD RT CAN NVRAM	FXPC154NQ2SDR20
FS154i-FK TS P2 SSD RT CAN NVRAM	FXPC154RF2SDR20
FS154i-FQ TS P2 SSD RT CAN NVRAM	FXPC154RQ2SDR20

	FXPC	15	4	N	F	1	H	D	R	1	0
Display Unit											
• LCD 15"		15									
Panel/Mechanical Variant											
• Fourth Generation			4								
Display Sensor											
• Touch Screen resistive				R							
• No Sensor				N							
Keyboard Type											
• 22 Function keys					F						
• 22 Function keys + Qwerty Keyboard					Q						
IPC Mother Board, Processor											
• Performance level P1						1					
• Performance level P2						2					
Mass Memory Type											
• HD (Hard Disk) ¹							H				
• SSD (Solid State Disc) ²							S				
Option Board											
• No fieldbus								N			
• CAN + NVRAM								D			
Flexium RTS											
• Real time									R		
Operating System											
• Windows 8 kernel ¹										1	
• Windows 10 kernel 64 bits ²										2	
Spare Number											0

¹ For performance level P1 only

² For performance level P2 only

FS194L, FS153 and FS122 Operator Panels (without Integrated iPC)

NUM has developed passive control panels for Flexium that are designed for use with an external PC or NUM Industrial Box PC P1/P2.

Three different passive panel sizes are available: 12" (FS122), 15" (FS153) units and 19" (FS194L).

The passive panels FS122 are available with and without touch screen. Both versions have got 22 functional keys.

The passive panels FS153-FK (keyboard option F) and FS153-FQ (keyboard option Q) have the same appearance and dimensions as NUM's FS154i panels, but do not have an integrated PC.

The passive panel FS194L is a landscape oriented projective, capacitive touch panel. The touch sensor supports dual-touch gestures.

The display quality makes the panels very legible, even in poorly-lit environments. Compact and very rugged, the panels are sealed (IP65) and suitable for use in severe industrial environments.

3

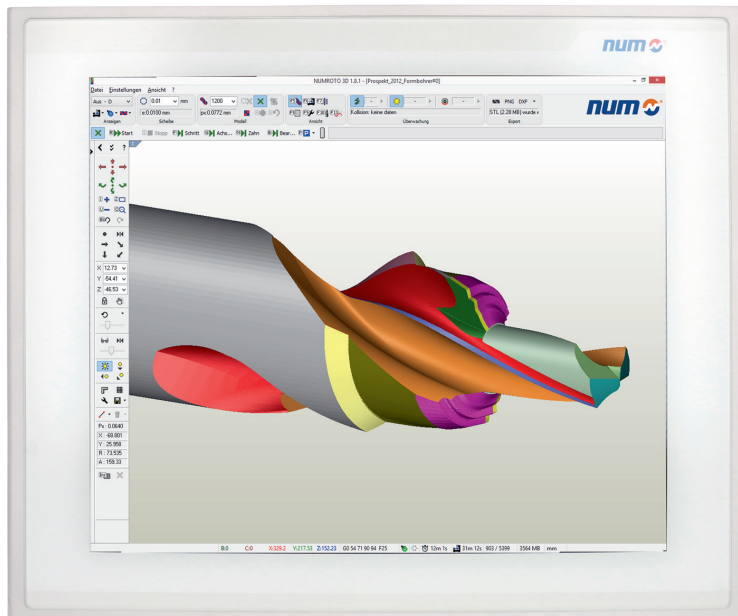

FS194L



FS122



FS153-FQ

FS194L Operator Panel

FS194L Operator Panel

With the latest 19-inch landscape oriented, projected capacitive touch screen system, NUM has set a new standard for operating panels in the machine tool industry.

The FS194L operator panel provides a durable, modern front end for machine control. It has an IP65 degree of protection at the front, and IP20 at the rear. High-quality 4 mm hardened safety glass protects the front, without introducing any disturbing reflections.

A narrow brushed aluminum frame with rounded edges provides complete side protection for the glass and multi-touch sensor.

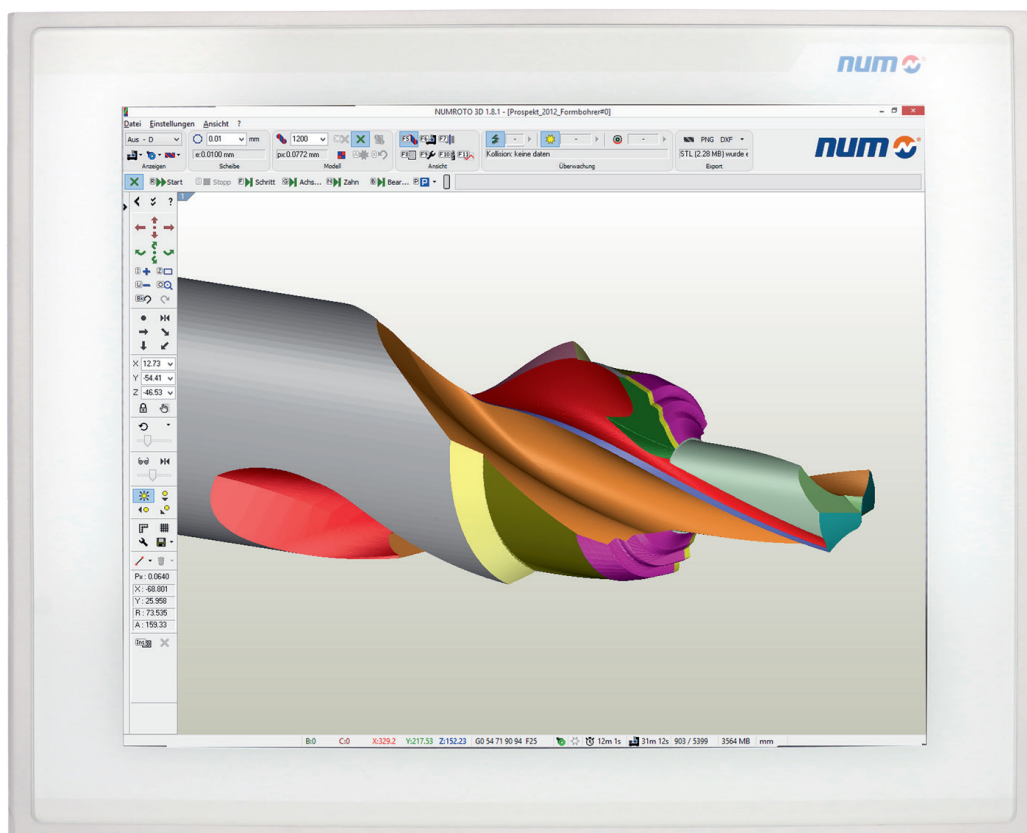



FS194L (without Integrated iPC) Technical Characteristics

		FXPC194LCNNNNN00
Screen	User interface options	Projected capacitive touch screen with hardened glass protection
	Technology	19" TFT LCD (16.9 million colours)
	Resolution	1280 x 1024 from 60Hz to 75Hz (horizontal/landscape orientation)
	Size	379 x 304 mm
	Backlight	Contr. 400:1 (Typ)
Main PC Features	CPU	External PC required
	RAM	
	Mass storage	
	Operating system	
	Graphic card	
Communication Interfaces	USB rear (3x)	V2.0 - 1.5/12/480 MBit/s, 2 USB Type A + 1 USB Type B
	DVI-I interface	1
	VGA	1
Power Supply	Rated voltage	24 VDC SELV, safety extra low voltage. Protection class III.
	Voltage range	24 VDC 20.4...27.6 VDC / rated for 4A continuous load
	Protection against reverse polarity	Yes
	Protection against over voltage	Yes
	Potential insulation	No. (The 0V-pin of the PS is connected to the digital GND)
	Power consumption	ca. 50 W / As point of reference, the 24V-power supply should be rated for 4A continuous load
Ambient Conditions	Climatic conditions operation	5...45 °C with horizontal mounting 10...90 % rel. air humidity, non-condensing
		The measuring point is defined 5cm over the top of the PC case in the middle of the vent holes. It is recommended to ensure enough air circulation
	Climatic conditions storage	-20...60 °C, 10...90 % rel. air humidity, non-condensing
	Climatic conditions transport	Class 2K3 EN50178 (reduced) -20...60 °C, 10...90 % rel. Air humidity, non-condensing
EMC	EMC immunity	Industry EN 61000-6-2
	EMC emission	Residential area EN 61000-6-3
Degree of Protection	Front	IP 65
	Rear	IP 20
Weight		8.5 kg
Dimensions	W x H x D	Please refer to the following pages
Noise		<70 dB

Outlines FS194L (without Integrated iPC)

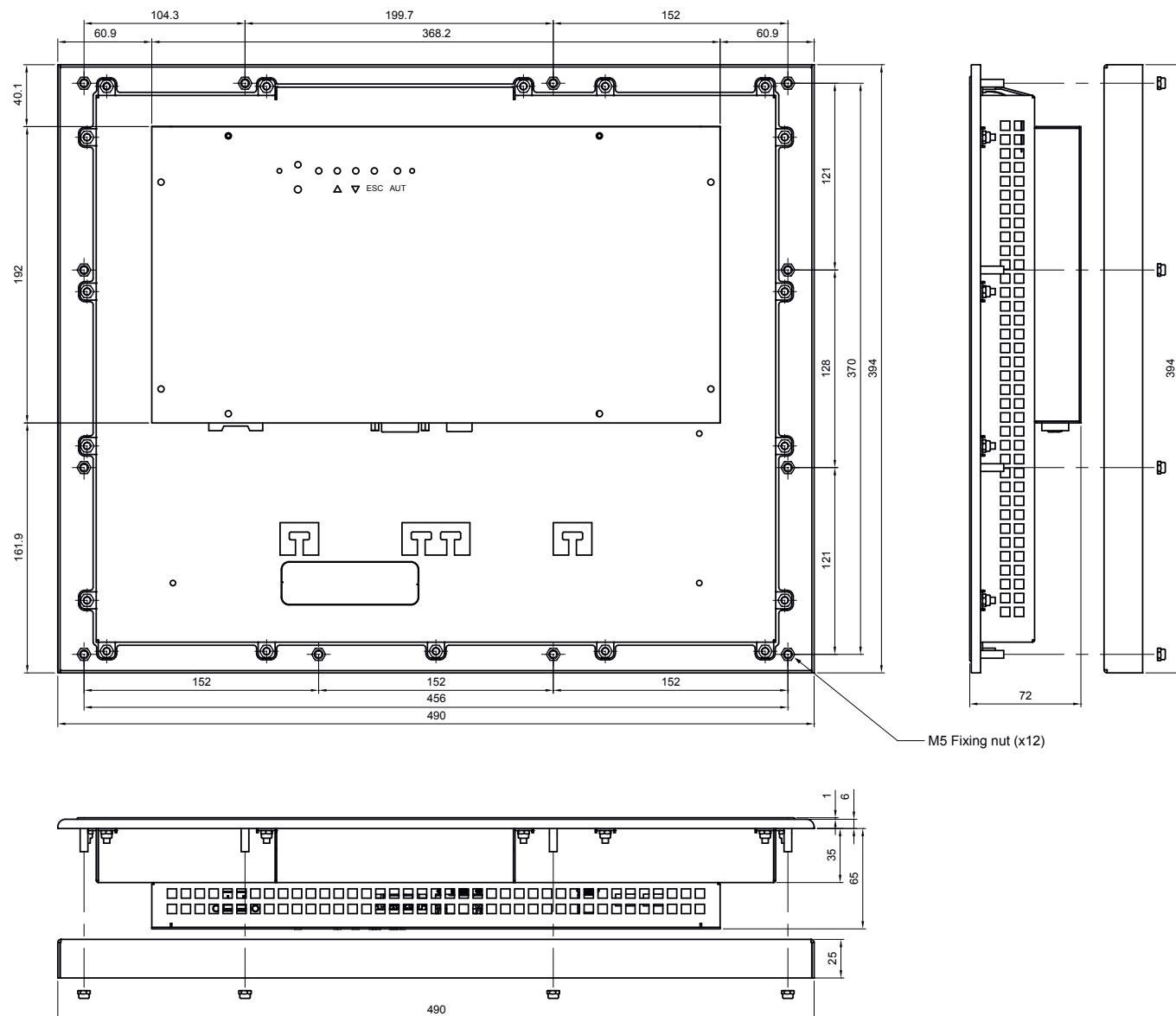



FS194L (without Integrated iPC) Cut-Out and Hole Patterns

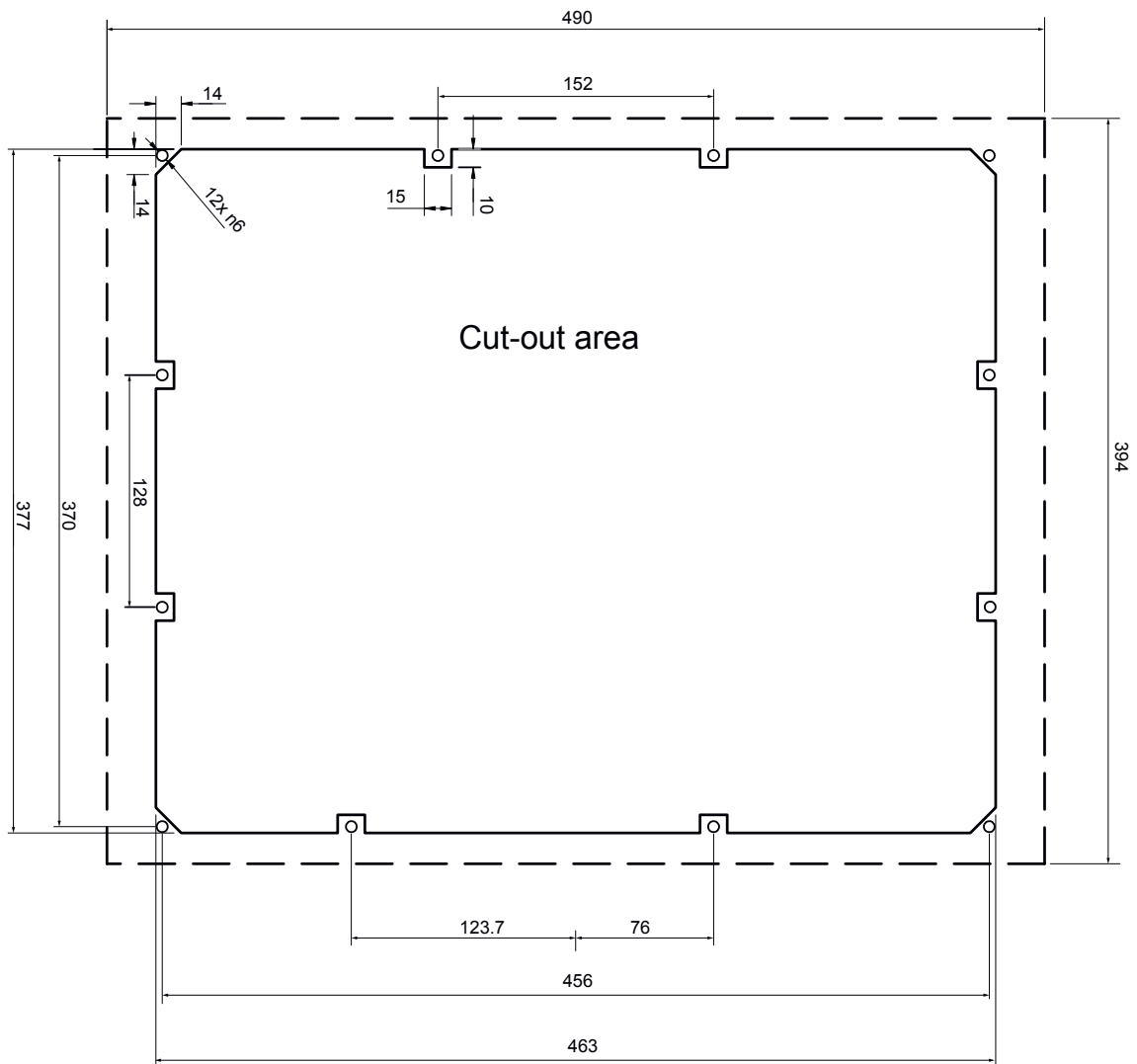

FS194L (without Integrated iPC) Cut-Out when using Back Side Mounting Plate

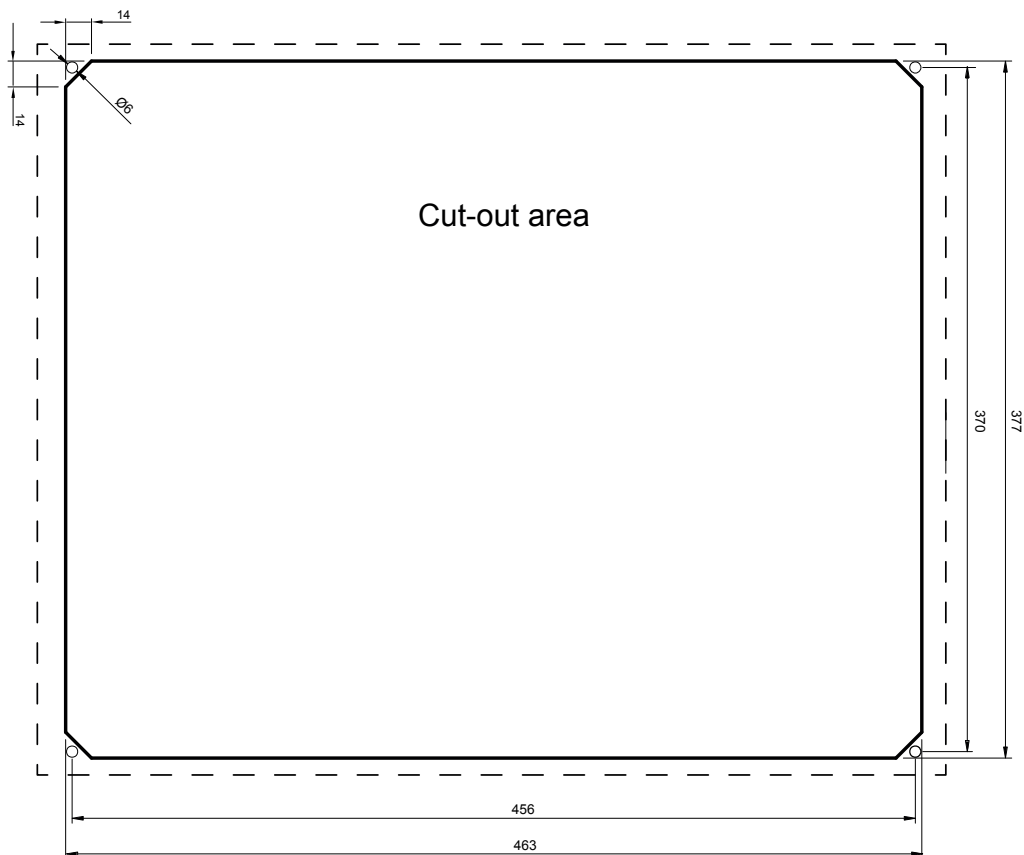

Cut-out in case of using back side mounting plate.

Operator Panels and Industrial PC

FS194L Operator Panel

Ordering Codes

FS194L Ordering Code

The FS194L panels are recommended with NUM Industrial Box PC P1/P2.

FS194L Version	Ordering Codes
FS194L-TS	FXPC194LNNNNN00

	FXPC	19	4	L	N	N	N	N	N	0	0
Display Unit											
• LCD 19"		19									
Panel/Mechanical Variant											
• Fourth generation			4								
Display Sensor											
• Touch Screen capacitive Landscape				L							
Keyboard Type											
• No keyboard, no function keys					N						
IPC Mother Board, Processor											
• No IPC, just operator panel						N					
Mass Memory Type											
• No IPC, just operator panel							N				
Option Board											
• No fieldbus, just operator panel								N			
Flexium RTS											
• No RTS, just operator panel									N		
Operating System											
• No IPC, just operator panel										0	
Spare Number											0

3

Operator Panels and Industrial PC

FS153 Operator Panels

User Interface Options

User Interface Options



Panel with 22 Function Keys

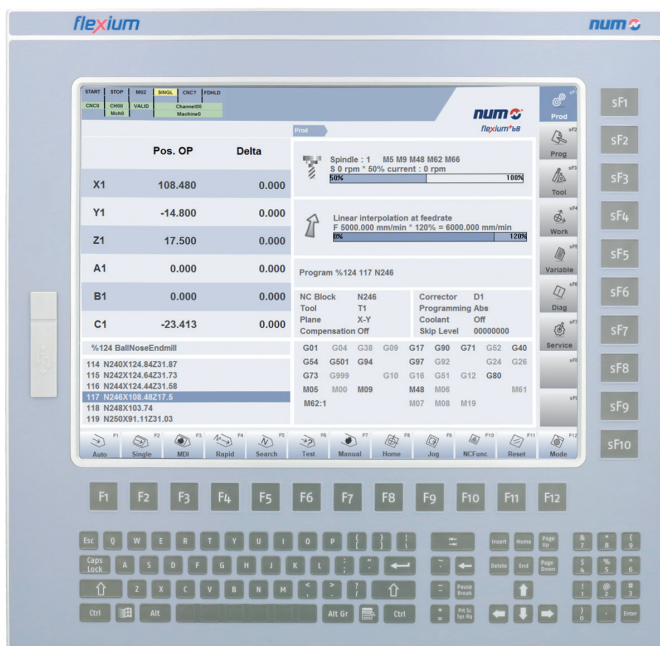

Panel with 22 Function Keys and QWERTY-Keyboard



FS153 (without Integrated PC) Technical Characteristics

		FXPC153xFNNNN00 FXPC153NQNNNN00
Screen	User interface options	Operator panel without integrated PC: <ul style="list-style-type: none"> • 22 Function Keys • 22 Function Keys and Qwerty Keyboard • Touch Screen (resistive)
	Technology	15" TFT LCD (16.9 million colors)
	Resolution	1024 x 768 from 60Hz to 75Hz
	Size	304 x 228 mm (12 x 9 inch)
	Backlight	LED, Contr. 700:1 (Typ)
Main PC Features	CPU	External PC required
	RAM	
	Mass storage	
	Operating system	
Communication Interfaces	USB front	1 x USB Type A
	USB rear	2 x USB Type A (only 1 x USB Type A in case of touch version) + 1 x USB type B
	DVI interface	1
	VGA interface	1
Power Supply	Rated voltage	24 VDC (+15%/-15%) SELV
	Protection against reverse polarity	Yes
	Protection against over voltage	Yes
	Potential insulation	No, the 0V pin is connected to the digital GND
	Power consumption	ca. 28 W
Environmental Conditions	Climatic conditions operation	0..50°C , 70% relative air humidity, non-condensing
	Climatic conditions storage	-20...60°C, 70% relative air humidity, non-condensing
	Climatic conditions transport	-20...60°C, 90% rel. air humidity, non-condensing
Degree of Protection	Front	IP 65
	Rear	IP 20
	Pollution degree	2
Weight		ca. 5.3 kg Function Key version ca. 5.7 kg Full Qwerty version
Dimensions	W x H x D	410 x 330 (400) x 53.2 mm
Cooling Type		Fanless

Outlines FS153 (without Integrated PC)

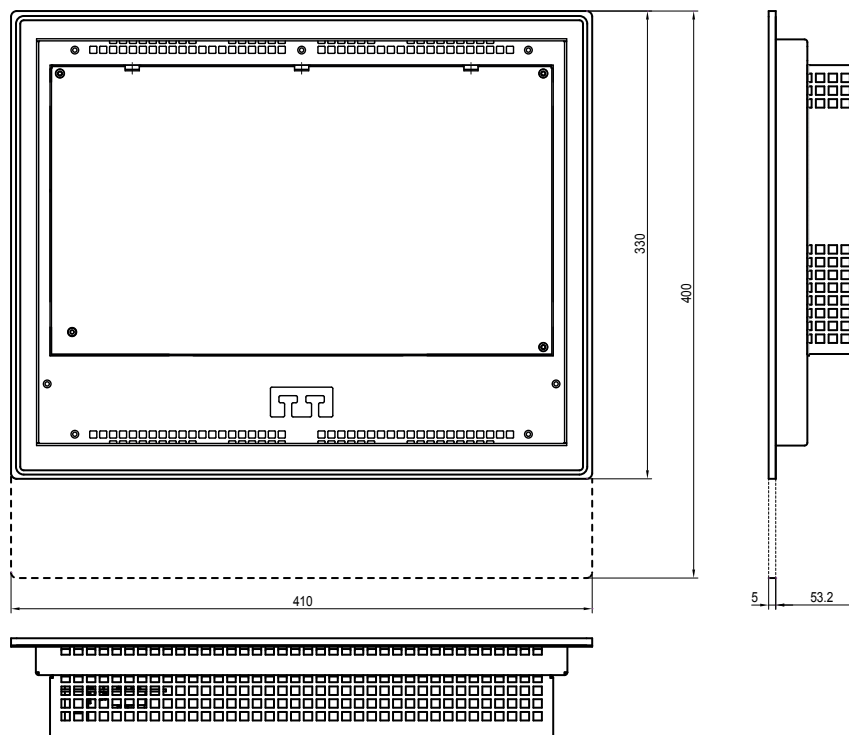

Operator Panel FS153 Cut-Out and Hole Pattern

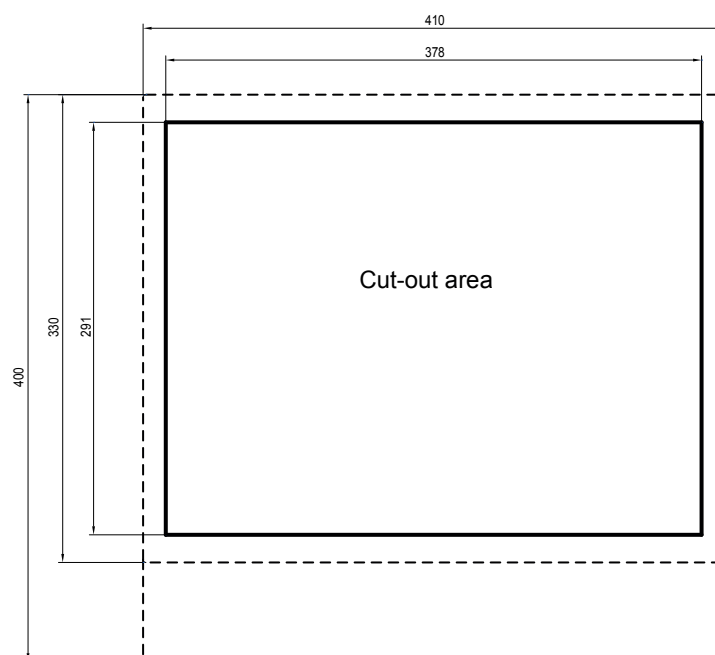

Dashed lines shows the panel dimensions

FS153 Operator Panels

Ordering Codes

FS153 Ordering Codes

The FS153 panels can be provided in two different versions and with two different fronts (function keys and function keys with QWERTY keyboard):

- FS153-FK: 15" Screen for PC-Panel with function keys
- FS153-FQ: 15" Screen for PC-Panel with function keys and QWERTY keyboard

FS153 Version	Ordering Codes
FS153-FK	FXPC153NFNNNN00
FS153-FK TS	FXPC153RFNNNN00
FS153-FQ	FXPC153NQNNNN00

3

	FXPC	15	3	R	F	N	N	N	N	0	0
Display Unit											
• LCD 15"		15									
Panel/Mechanical Variant											
• Third generation			3								
Display Sensor											
• Touch screen resistive				R							
• No touch Sensor				N							
Keyboard Type											
• 22 Function keys					F						
• 22 Function keys + Qwerty keyboard					Q						
IPC Mother Board, Processor											
• No IPC, just operator panel						N					
Mass Memory Type											
• No IPC, just operator panel							N				
Option Board											
• No fieldbus, just operator panel								N			
Flexium RTS											
• No RTS, just operator panel									N		
Operating System											
• No IPC, just operator panel										0	
Spare Number											0

Operator Panels and Industrial PC

FS122 Operator Panel User Interface Options

User Interface Options

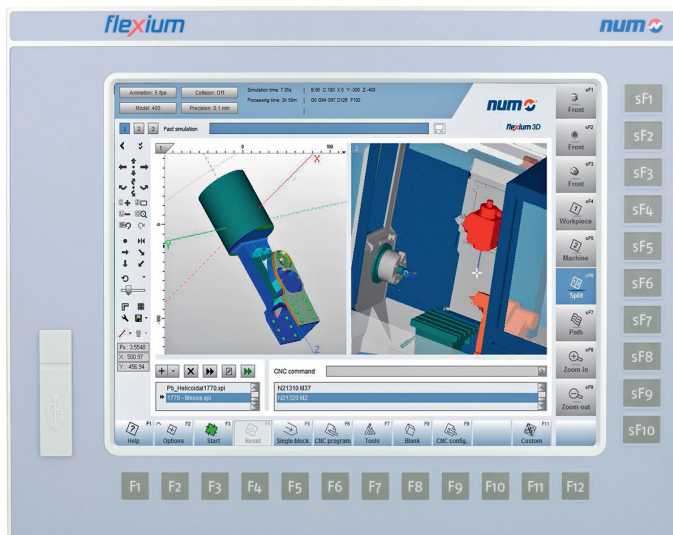

Panel with 22 Function Keys

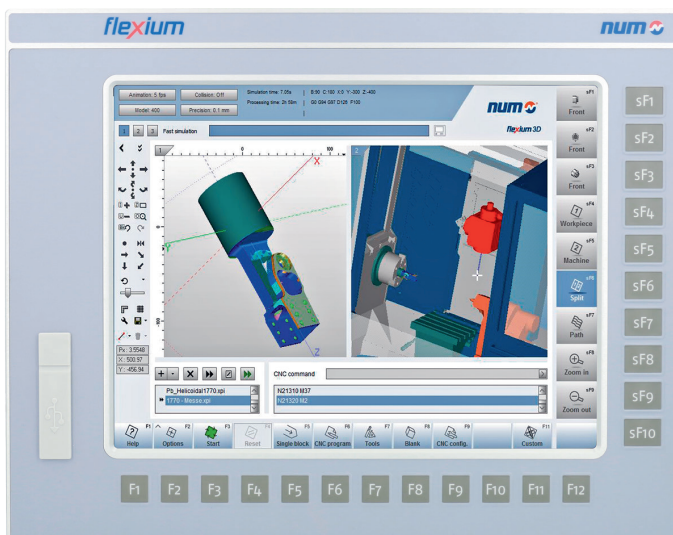

Panel with 22 Function Keys and Resistive Touch Screen



FS122 Technical Characteristics

		FXPC122xFNNNN00
Screen	User interface options	22 Function Keys Resistive touch screen available as option
	Technology	12.1" LED
	Resolution	1024 x 768 on 60 Hz till 75 Hz
	Size	Diagonal 307 mm
	Contrast	Contr. 700:1
	Brightness	600 cd/m ²
Main PC Features	CPU	External PC required
	RAM	
	Mass storage	
	Operating system	
	Graphic card	
Communication Interfaces	USB front (1x)	V2.0 - 1.5/12/480 MBit/s USB Type A
	USB rear (3x)	V2.0 - 1.5/12/480 MBit/s 2 USB Type A + 1 USB type B (1)
	DVI interface	1
	VGA interface	1
Power Supply	Rated voltage	24 VDC SELV, safety extra low voltage. Protection class III
	Voltage range	24 VDC 20.4...28.8 VDC / rated
	Protection against reverse polarity	Yes
	Protection against over voltage	Yes
	Potential insulation	No. (The 0V-pin of the PS is connected to the digital GND)
	Power consumption	ca. 25 W. As point of reference, the 24V-power supply should be rated for 4A continuous load
Ambient Conditions	Climatic conditions operation	0...50 °C , 10...90 % relative air humidity, non-condensing
	Climatic conditions storage	-20...60 °C , 10...90 % relative air humidity, non-condensing
	Climatic conditions transport	Class 2K3 EN50178 (reduced -20...60°C, 10...90% relative air humidity, non-condensing)
EMC	EMC immunity	Industry EN 61000-6-2
	EMC emission	Residential area EN 61000-6-3
Degree of Protection	Front	IP 65
	Rear	IP 20
Weight		3.45 kg
Dimensions	W x H x D	347 x 276 x 63 mm
	Cut out	331 x 260 mm (+0/-1mm)

FS122 Outlines

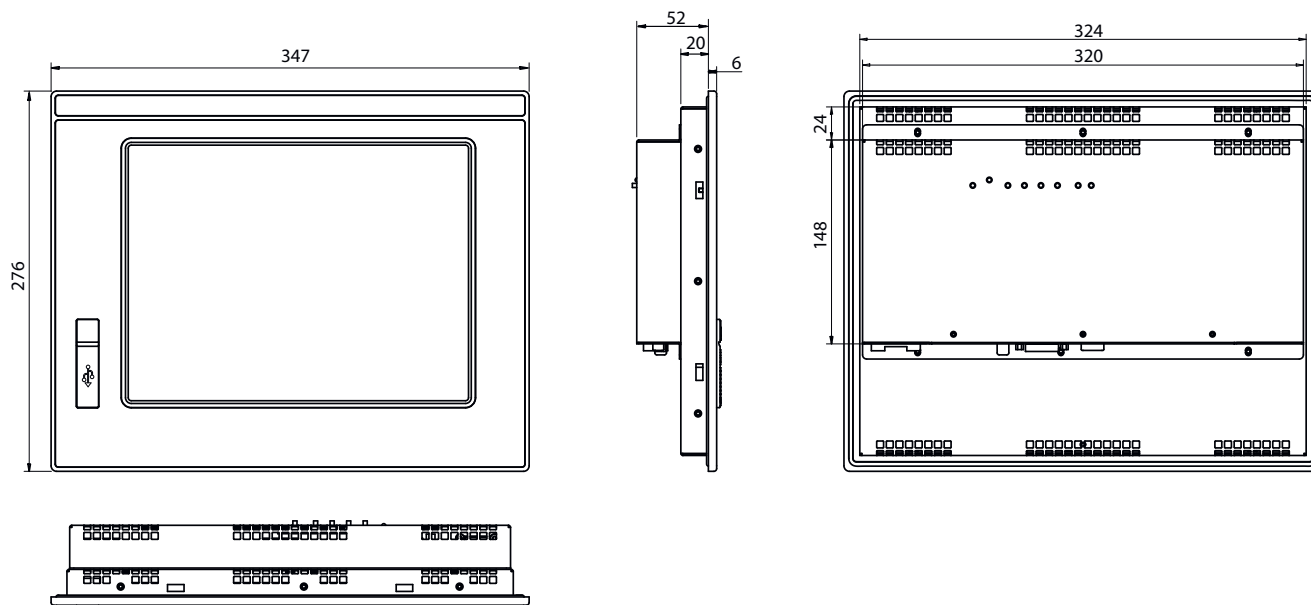

Cut-Out and Pattern

For FS122 a simple rectangle cut-out is needed (no holes); the cut-out has the following dimensions: 331 x 260 mm (+0/-1mm).

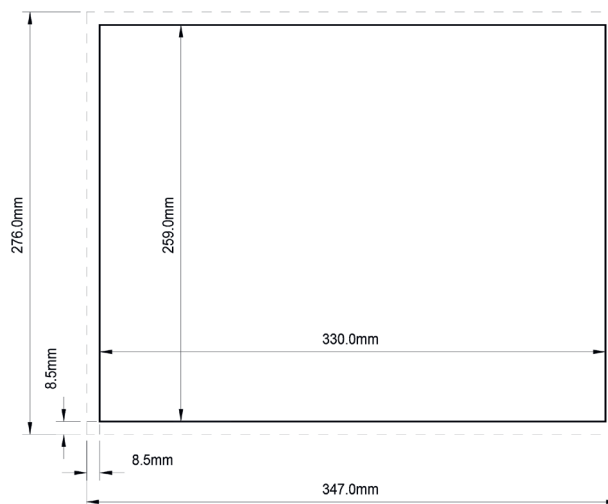

FS122 Ordering Codes

FS122 Version	Ordering Codes
FS122-FK-TS	FXPC122RFNNNN00
FS122-FK	FXPC122NFNNNN00

	FXPC	12	2	R	F	N	N	N	N	N	0	0
Display Unit • LCD 12"		12										
Panel/Mechanical Variant • Second generation			2									
Display Sensor • Touch screen resistive • No touch Sensor				R N								
Keyboard Type • 22 Function keys					F							
IPC Mother Board, Processor • No IPC, just operator panel						N						
Mass Memory Type • No IPC, just operator panel							N					
Option Board • No fieldbus, just operator panel								N				
Flexium RTS • No RTS, just operator panel									N			
Operating System • No IPC, just operator panel											0	
Spare Number												0

Machine Panels

NUM offers 4 different machine panels typically used for manually controlling movement, production initiation and intervention during machining.

MP04, MP06 and MP08 machine panels include:

- 60 configurable buttons with LEDs
- 2 potentiometers for spindle speed and feed rate override. Possibility of replacement by selectors for MP06
- 1 Handwheel (as optional)
- 1 Emergency stop button (MP04 and MP06 only)
- 1 Three-position key switch
- 3 Dedicated buttons: Reset (white LED) Cycle Stop (Red LED), Cycle Start (green LED)

MP06 and MP08 button actuate real mechanical switches and are connected to the Flexium⁺ system by means of an EtherCAT fieldbus. Each button can be simply customized by inserting an icon in each key (that can be opened).

MP06 is designed to fit FS153 and FS154i panel dimensions.

MP08 is designed to fit FS122 panel dimensions.

MP04 uses membrane switches and it's connected to the Flexium⁺ system by means of an CAN fieldbus. The industrial PC option be ordered with the CAN option.

MP04 is designed to fit FS153 and FS154i panel dimensions.

MP05 is designed to accompany the FS194i touch panel.



Machine Panel MP04



Machine Panel MP05

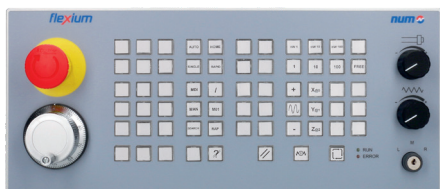

Machine Panel MP06

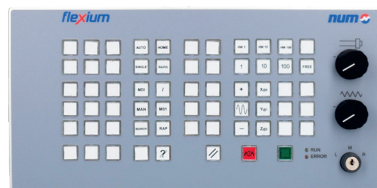

Machine Panel MP08

MP04 Machine Panel

MP04 Machine Panel

This panel is used for manually controlling movement, production initiation and intervention during machining.

Two versions are available:

- Machine Panel MP04–W, without handwheel (reference FXHE558110)
- Machine Panel MP04–H, with handwheel (reference FXHE558120)

The panels provide:

- 55 configurable keys with LEDs
- 2 potentiometers for spindle speed and feed rate override
- 1 handwheel (FXHE558120 only)
- 1 emergency stop button
- 1 three-position key switch
- 3 controls: Cycle start, Cycle stop and Reset
- 5 keys for additional functions with LEDs

The MP04 has to be connected via CAN. For the handwheel, which is mounted on MP04 machine panel two type of connections are possible; either connected via CAN or directly hooked up at CNC.



MP04 Machine Panel

Options

MP04 Machine Panel MP04-H (with Handwheel)

- CAN interface
- 63 programmable function keys
- Same width as FS154i
- Handwheel



MP04 Machine Panel MP04-W (without Handwheel)

- CAN interface
- 63 programmable function keys
- Same width as FS154i





MP04 Machine Panels Technical Characteristics

		FXHE558110	FXHE558120
MP04 Panel	User interface	63 freely programmable keys	63 freely programmable keys
	Handwheel	Not present	Yes (100 Pulses per revolution)
	CAN interface	Yes (9 Pins Sub-D)	
On Board Sensor	Key switch	3 positions	
	Potentiometer	For spindle speed override (10 kOhm potentiometers, 2.5 VDC, 10 Bit resolution) For feed rate override (10 kOhm potentiometers, 2.5 VDC, 10 Bit resolution)	
	1 input for handwheel	For a 5 VDC handwheel with A & B push-pull signal, max. 100mA	
	Emergency stop	1	1
Press Buttons	55 softkeys with LED	Free configurable	
	3 controls with LED	Cycle start, cycle stop and reset	
	5 softkeys with LED	Free configurable for additional functions with LED	
Digital Inputs	12 digital inputs	Organisation: 3 groups of semiconductor type terminals	
	Operating voltage	24V -15% / +10% (20.4 –26.4V)	
	Logic 0	0 to 5 VDC	
	Logic 1	6 to 26.4 VDC	
	In current	4 mA typical at 24 VDC	
	Reaction time	8 ms typical (debounced)	
Digital Outputs	12 digital outputs	Organisation: 3 groups of semiconductor type terminals	
	Operating voltage	24V -15% / +10% (20.4 –26.4V)	
	Rated current	100 mA maximum per output	
	Outputs simultaneously active	100%	
	Protection	Short-circuit and permanent overloads (trip device)	
Power Supply	Rated voltage	24 VDC SELV, safety extra low voltage. Protection class III / 1A	
	Voltage range	24 VDC 20.4...28.8 VDC	
	Protection against reverse polarity	Yes	
	Protection against over voltage	Yes	
	Fuse protection	Yes, self resettable	
	Potential isolation	No. (The 0V-pin of the PS is connected to the digital GND)	
	Power consumption	ca. 15 W (max)	
Ambient Conditions	Climatic conditions operation	0...45°C with mounting, 10...90% rel. air humidity, non-condensing	
	Climatic conditions storage	-20...60°C, 10...90% rel. air humidity, non-condensing	
	Climatic conditions transport	Class 2K3 EN50178 (reduced) -20...60°C, 10...90% rel. Air humidity, non-condensing	
EMC	EMC immunity	Industry EN 61000-6-2	
	EMC emission	Residential area EN 61000-6-3	
	Electrical safety	EN 60950 and EN 50178	
	Conformity	MP04-W and MP04-H meets the requirements specified by the EU Council Directives for harmonizing the regulations of EU member states relating to electromagnetic compatibility (89/336/EEC)	
Degree of Protection	Front	IP 65 (NEMA 12), EN 60068-2-68	
	Rear	IP 20	
Weight		ca. 1.2 kg	ca. 1.3 kg
Dimensions	W x H x D	410 x 330 x 65 mm	410 x 400 x 65 mm
	Cut-out	378 x 298 mm (+0/-1 mm) / Please refer to next pages	

MP04 Machine Panel

Ordering Codes

MP04-H and MP04-W Machine Panel Ordering Codes

- Machine Panel MP04–W without handwheel
- Machine Panel MP04–H with handwheel

MP04 Version	Ordering Codes
Machine Panel MP04-W	FXHE558110
Machine Panel MP04-H	FXHE558120

MP05 Machine Panel

MP05 Machine Panel

To accompany the new FS194i touch panel, NUM has launched the MP05 machine panel. This uses the same 4 mm hardened safety glass as the FS194i and has the same IP65 protection level at the front. A solid aluminum frame with back plate ensures correct stiffness.

MP05 complements the FS194i's virtual machine panel by adding physical interfaces for functions that need tactile feedback.

The combination provides OEMs with a powerful competitive advantage.

Components of the machine panel:

- E-Stop button
- 6 luminous push buttons (e.g. NC-Start, NC-Stop, customizable)
- USB interface
- 2 Overrides potentiometers 10k Ω (Feed rate and Spindle, adjustable via PLC)
- Handwheel (100 Impulses/rev. 5V - A, B)

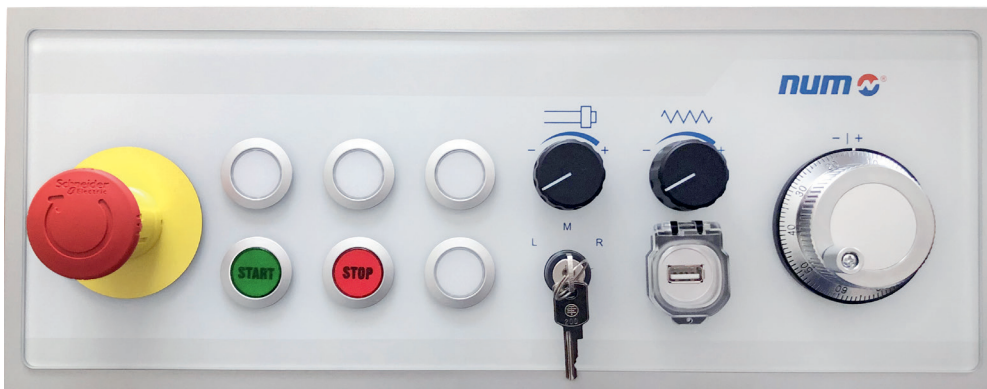

MP05 Machine Panel Outlines

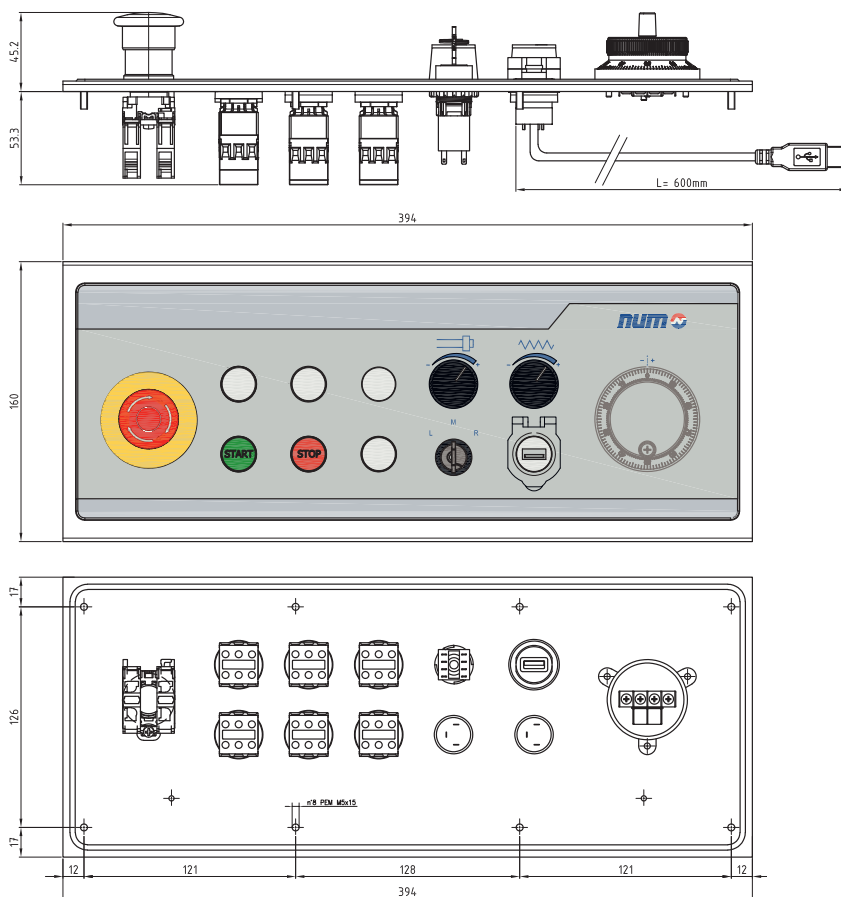

3

Cut-Out and Hole Pattern

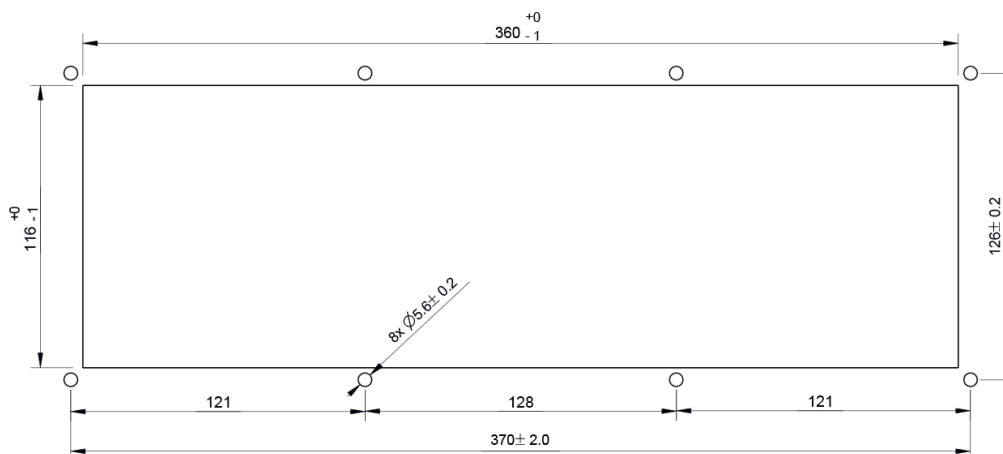

MP05 Machine Panel

Ordering Codes

MP05 Machine Panel

Machine Panel MP05 available versions:

MP05 with Handwheel	Ordering Codes
Machine Panel MP05-H	FXHE03NBE1HN000

MP06 Machine Panel

MP06 Machine Panel

This panel is used for manually controlling movement, production initiation and intervention during machining. MP06 is designed to fit FS153 and FS154i panel dimensions.

MP06 includes:

- 60 configurable buttons with blue LEDs
- 2 Overrides potentiometers or selector for spindle speed and feed rate
- 1 Handwheel (as optional)
- 1 Emergency stop button
- 1 Three-position key switch
- 3 Dedicated buttons: Reset (white LED) Cycle Stop (Red LED), Cycle Start (green LED)
- 2 Dedicated LEDs for EtherCAT state: RUN and ERROR

MP06 is connected to the Flexium system with EtherCAT.

3

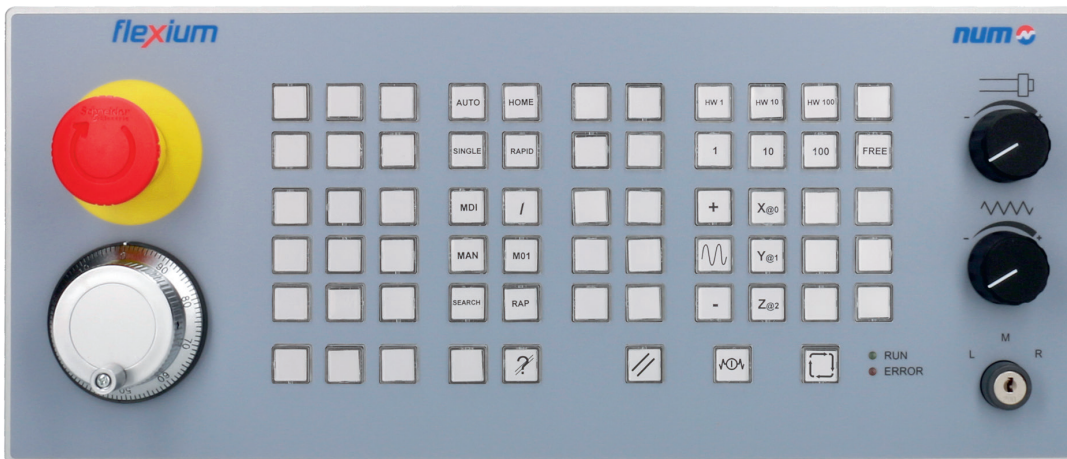

MP06 Machine Panels Technical Characteristics

		FXHE02ARE1WE000	FXHE02ARE1HE000	FXHE02ARE2WE000	FXHE02ARE2HE000
Interfaces	Communication interface	Standard EtherCAT 2xRj45			
	Handwheel input	1 input for 5Vdc handwheel with A & B push-pull signal			
	Key switch	1 key switch with 3 positions			
	Potentiometer	2 potentiometers 10 kOhm, 8 Bit resolution		Not present	
	Selector	Not present		2 switch selectors with 25 positions	
	Handwheel	Not present	Yes (100 Pulse per rev.)	Not present	Yes (100 Pulse per rev.)
	Emergency stop	1			
Press Buttons	Free configurable	60 buttons with mechanical switches with LEDs			
	Cycle start, cycle stop and reset	3 buttons with mechanical switches with LEDs			
Digital Inputs	Digital inputs	12 organized in 2 groups of terminals			
	Logic 0 / Logic 1	0 < 6 VDC (or < 3mA) 1 > 10 VDC up to 30 VDC (or > 5 mA up to 15 mA)			
Digital Outputs	Digital outputs	12 organized in 3 groups of terminals			
	Rated current	500 mA maximum per output			
	Protection	Short-circuit and permanent overloads (trip device)			
Power Supply	Rated voltage	24 VDC (from 18 VDC up to 30 VDC)			
	Protection against reverse polarity	Yes			
	Protection against over voltage	Yes			
	Potential isolation	No. (The 0V-pin of the PS is connected to the digital GND)			
	Power consumption	15 W max			
Ambient Conditions	Climatic conditions, operation	0..45°C, 70% rel. air humidity, non-condensing			
	Climatic conditions, storage & transport	-20...80°C, 70% rel. air humidity, non-condensing			
Degree of Protection	Front	IP 65			
	Rear	IP 00			
Weight		1.2 kg	1.4 kg	1.2 kg	1.4 kg
Dimensions	W x H x D	410 x 175 x 55 mm			
	Cut-out	380 x 145 mm (+0/-1mm)			

MP06 Machine Panel Outlines

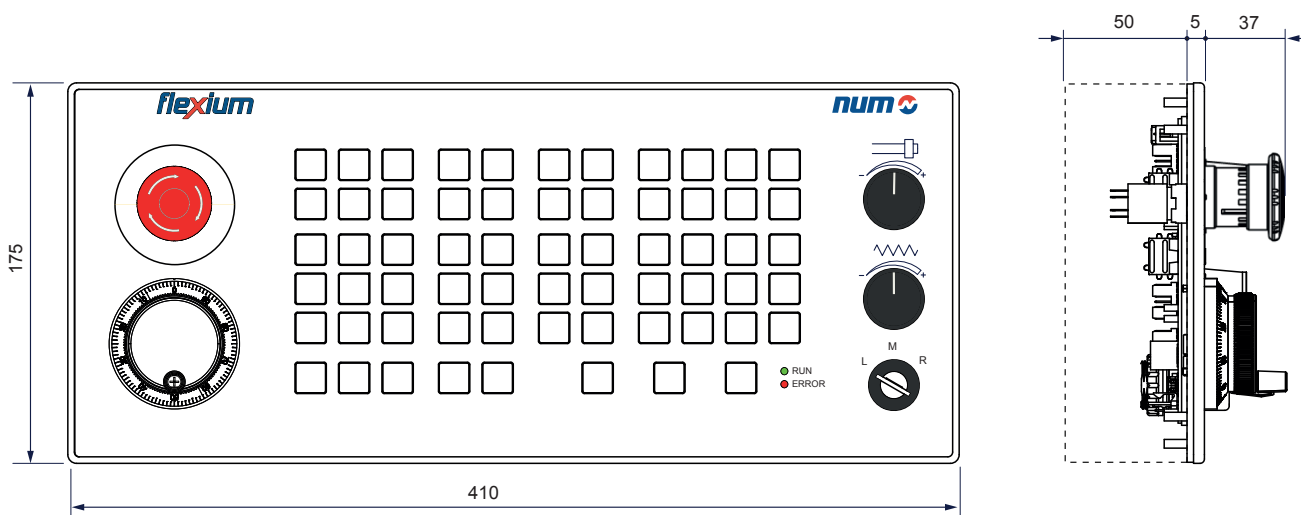

3

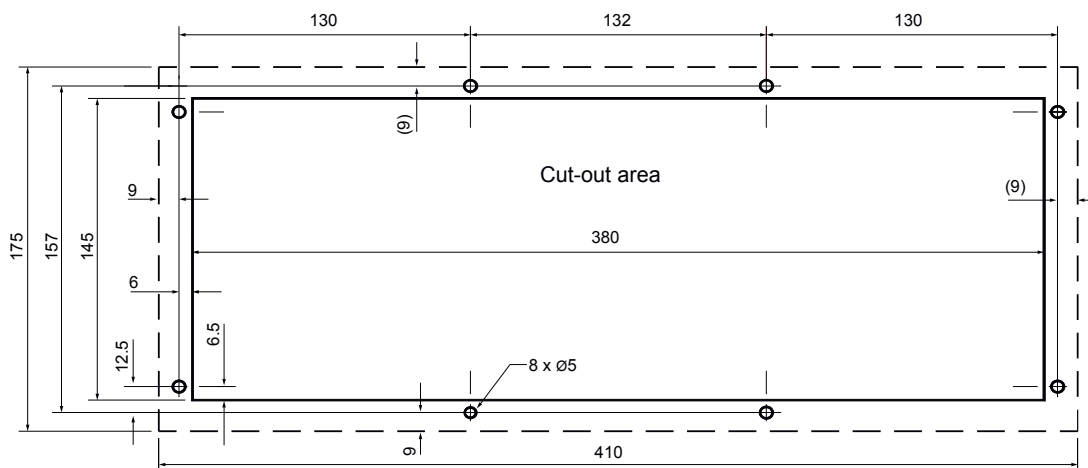

MP06 Machine Panel

Ordering Codes

MP06 Machine Panel

Machine Panel	Ordering Codes
Machine Panel MP06–W without handwheel and potentiometers	FXHE02ARE1WE000
Machine Panel MP06–H with handwheel and potentiometers	FXHE02ARE1HE000
Machine Panel MP06–W without handwheel and selectors	FXHE02ARE2WE000
Machine Panel MP06–H with handwheel and selectors	FXHE02ARE2HE000

MP08 Machine Panel

MP08 Machine Panel

MP08 has got identical characteristics as MP06, the only differences are:

- Smaller width dimension to fit FS122 panels
- E-STOP button and handwheel are not foreseen



MP08 Machine Panels Technical Characteristics

		FXHE01ARD1WE000	FXHE01ARD2WE000
Interfaces	Communication interface	Standard EtherCAT 2x Rj45	
	Handwheel input	1 input for 5 VDC handwheel with A & B push-pull signal	
	Key switch	1 key switch with 3 positions	
	Potentiometer	2 potentiometers 10 kOhm, 8Bit resolution	Not present
	Selector	Not present	2 switch selectors with 25 positions
	Handwheel	Not present	
	Emergency stop	Not present	
Press Buttons	Free configurable	60 buttons with mechanical switches with LEDs	
	Cycle start, cycle stop and reset	3 buttons with mechanical switches with LEDs	
Digital Inputs	Digital inputs	12 organized in 2 groups of terminals	
	Logic 0 / Logic 1	0 < 6 VDC (or < 3mA) 1 > 10 VDC up to 30 VDC (or > 5 mA up to 15 mA)	
Digital Outputs	Digital outputs	12 organized in 3 groups of terminals	
	Rated current	500 mA maximum per output	
	Protection	Short-circuit and permanent overloads (trip device)	
Power Supply	Rated voltage	24 VDC (from 18 VDC up to 30 VDC)	
	Protection against reverse polarity	Yes	
	Protection against over voltage	Yes	
	Potential isolation	No. (The 0V-pin of the PS is connected to the digital GND)	
	Power consumption	15 W max	
Ambient Conditions	Climatic conditions, operation	0..45°C, 70% rel. air humidity, non-condensing	
	Climatic conditions, storage & transport	-20...80°C, 70% rel. air humidity, non-condensing	
Degree of Protection	Front	IP 65	
	Rear	IP 00	
Weight		1.2 kg	
Dimensions	W x H x D	347 x 175 x 55 mm	
	Cut-out	317 x 145 mm (+0/-1mm)	

MP08 Machine Panel

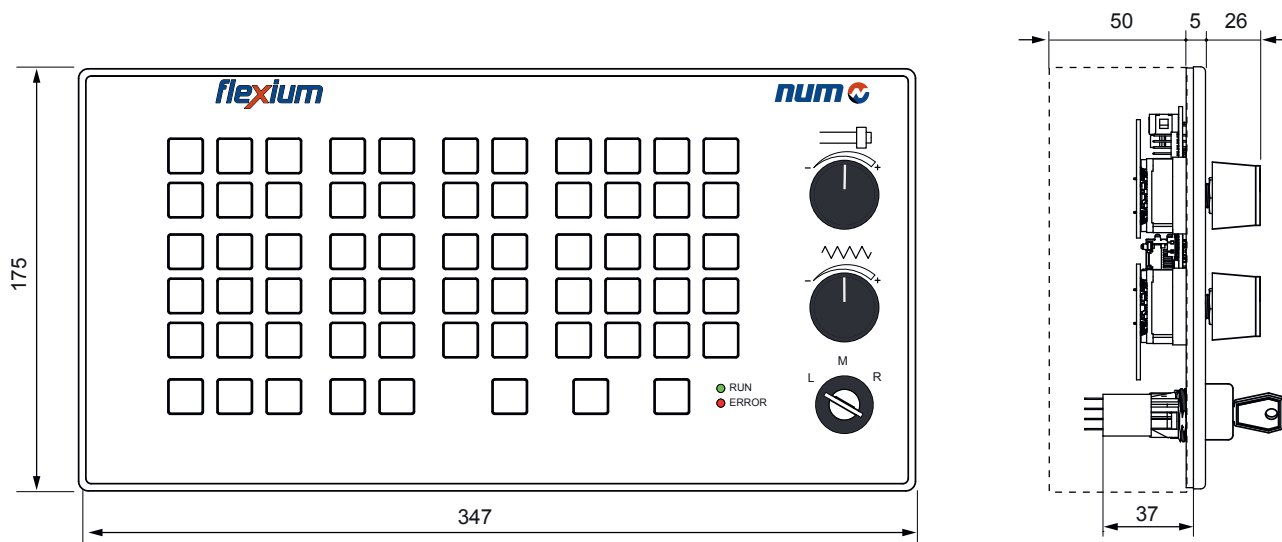

3

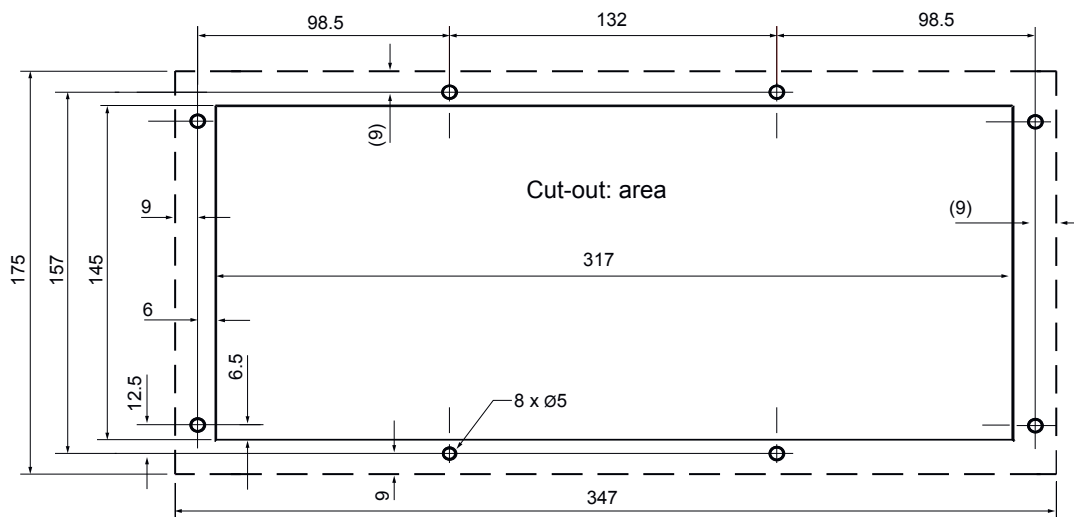

MP08 Machine Panel

Ordering Codes

MP08 Machine Panel

Machine Panel	Ordering Codes
MP08 with potentiometers	FXHE01ARD1WE000
MP08 with selectors	FXHE01ARD2WE000

MP06 and MP08 Ordering Codes

	FXHE	01	A	R	D	1	W	E	0	0	0
Index / Mechanical variant											
• MP08 (x FS122)		01									
• MP06 (x FS153)		02									
Integrated I/Os											
• 12 digital inputs and 12 digital outputs			A								
Keys number and technology											
• 63 x keys with real switches				R							
Safety functions											
• 3 positions key switch (MP08 only)											
• E-STOP + 3 positions key switch (MP06 only)											
Override feedrate and spindle											
• 2 potentiometers											
• 2 selectors with mechanical indexing											
Handwheel											
• None											
• Handwheel (MP06 only)											
Connections Technology											
• EtherCAT + wires for safety related devices											
Spare Number											
Spare Number											
Spare Number											

Vertical and horizontal keyboard for FS153 and FS154i

Add a horizontal keyboard in case of FS154i in touch screen version. Add a vertical keyboard (with a blanking plate) in case of using MP04 or MP06 in conjunction with an FS153 or FS154i in touch screen version.

Machine Panel	Ordering Codes
Vertical USB keyboard including blanking plate	FXHE000248
Horizontal USB keyboard	FXHE000249

3



Horizontal USB Keyboard



Vertical USB Keyboard

Application Example

FS154i, MP04, vertical Keyboard and plain cover board.

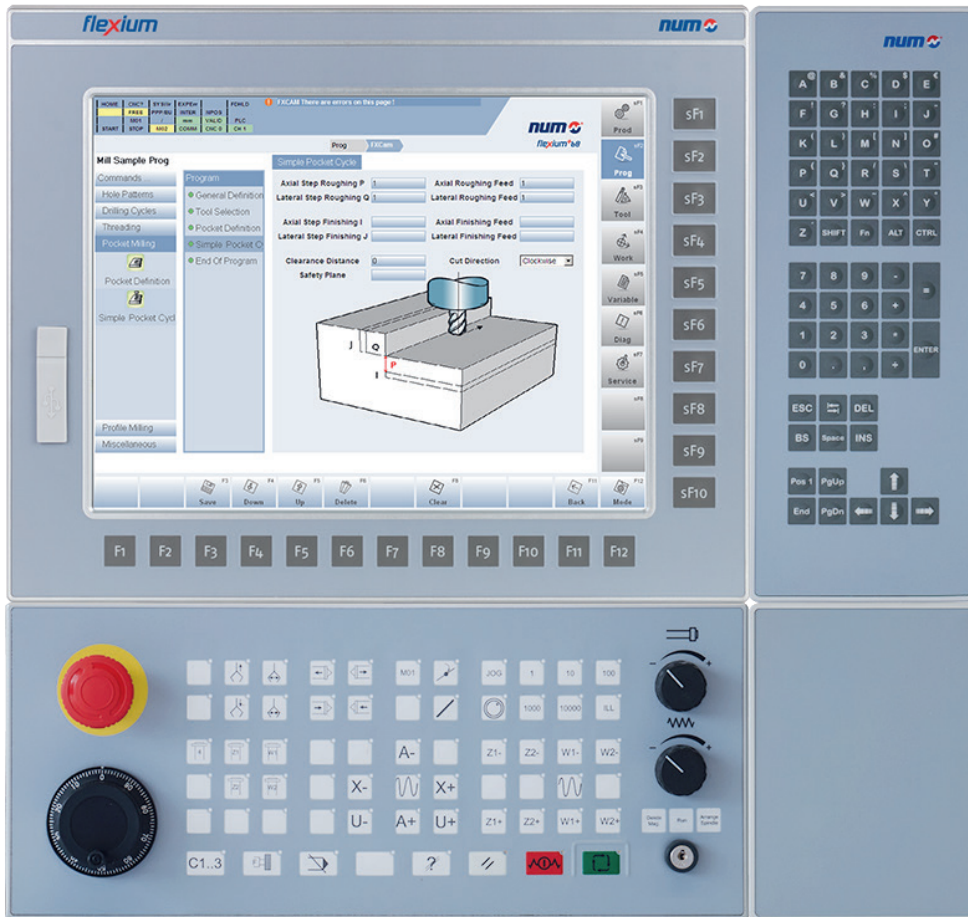

NUM Industrial Box PC

NUM's Industrial Box PC provide a powerful and ergonomic platform for the Flexium⁺ system, enabling you to interact with the machine in a simple and logical manner. Two performance levels are available: P1 and P2 both with quad-core processors.

NUM's Industrial Box PC can be used in two different ways:

- For very demanding applications that require a powerful workstation (e.g. for CAD/CAM), Industrial Box PC handles only the Flexium⁺ PLC.
- NUM's Industrial Box PC can be used with an FS153 passive panel to handle the Flexium HMI as well as the Flexium⁺ PLC.

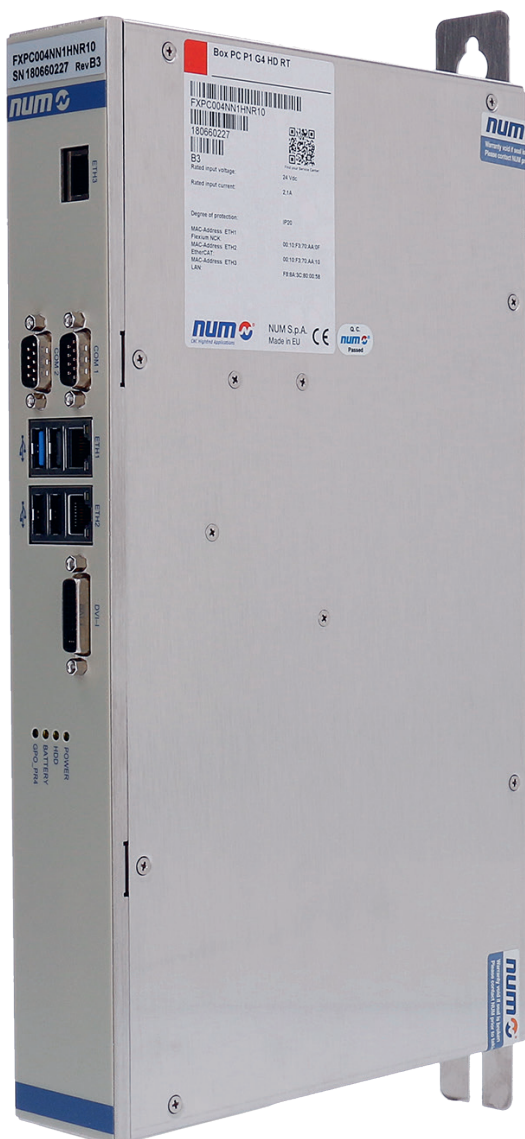

NUM Industrial Box PC P1 (FXPC004NN1HxR10)

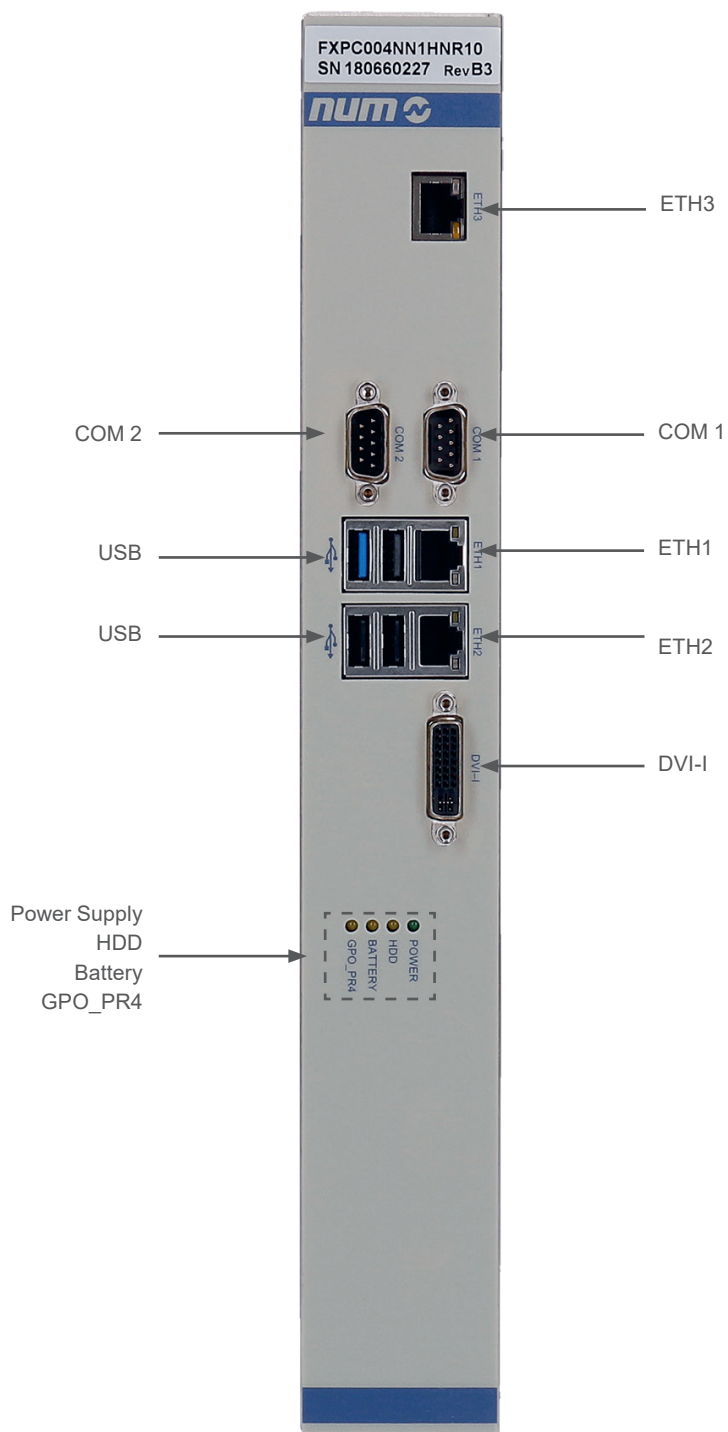

NUM Industrial Box PC P2 (FXPC004NN2SxR20)

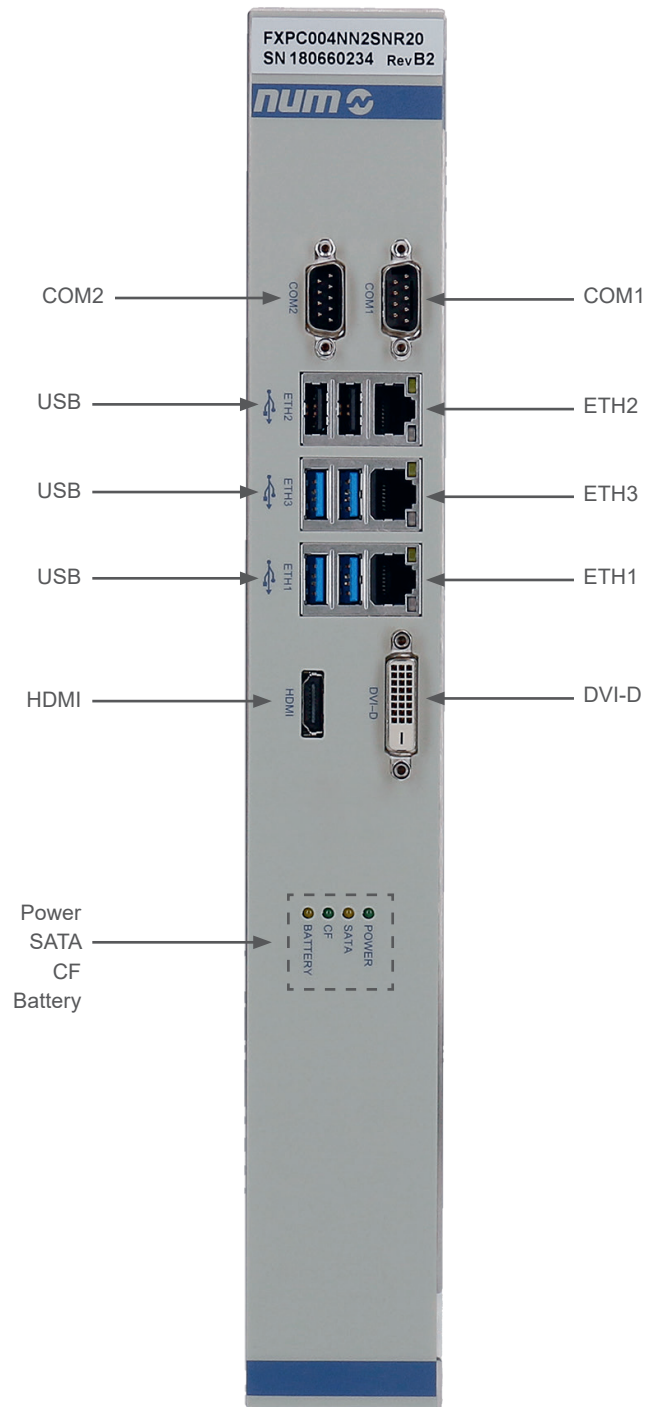

NUM Industrial Box PC Technical Characteristics

		FXPC004NN1HxR10 (PC P1 G4)	FXPC004NN2SxR20 (PC P2 G4)
Main PC Features	CPU	Intel® Celeron™ CPU J1900 @ 2GHz Quad Core	i5-6500TE 2.3GHz Quad Core
	RAM	2 GB	8 GB
	Mass storage	> 250 GB Hard Disk	Industrial SSD 64 GB
	Operating system	Windows Embedded 8.1 Industry Pro	Windows 10 IoT Enterprise LTSB 64 bits
Communication Interfaces	Ethernet (ETH)	3 x Gigabit LAN / RTE	
	CAN+NVRAM	2 - CAN1 / CAN2 (as option)	
	USB	3 x USB 2.0 Type A and 1 x USB 3.0 Type A	2 x USB 2.0 Type A and 4 x USB 3.0 Type A
	COM	2	2
	PS2	0	
	VGA	0	0
	DVI interface	1 DVI-I	1 DVI-D
	HDMI	No	1
Power Supply	Rated voltage	24 VDC (+15%/-15%) 2.1A	24 VDC (+15%/-15%) / 4A
	Protection fuse	Yes. Internal fuse 2A/250V	
	Power consumption	typ. 21 W max. 50 W (2.1 A)	typ. 48 W max. 96 W (4A)
Ambient Conditions	Climatic conditions operation	0...45°C, 70% rel. air humidity, non-condensing	
	Climatic conditions storage	-20...60°C, 70% rel. air humidity, non-condensing	
	Environmental conditions installation	Requires protection to at least IP54	
	Climatic conditions transport	-20...60°C, 10...90% rel. Air humidity, noncondensing	
Degree of Protection	IP20		
Pollution Degree	2		
Cooling Type	Fan-less		Internal (with fan)
Weight	ca. 2.4 kg		ca. 2.5 kg
Dimensions	W x H x D	50 x 355 (410) x 206 mm (Please refer to the next pages)	

NUM Industrial Box PC P1 Outlines (FXPC004NN1HxR10)

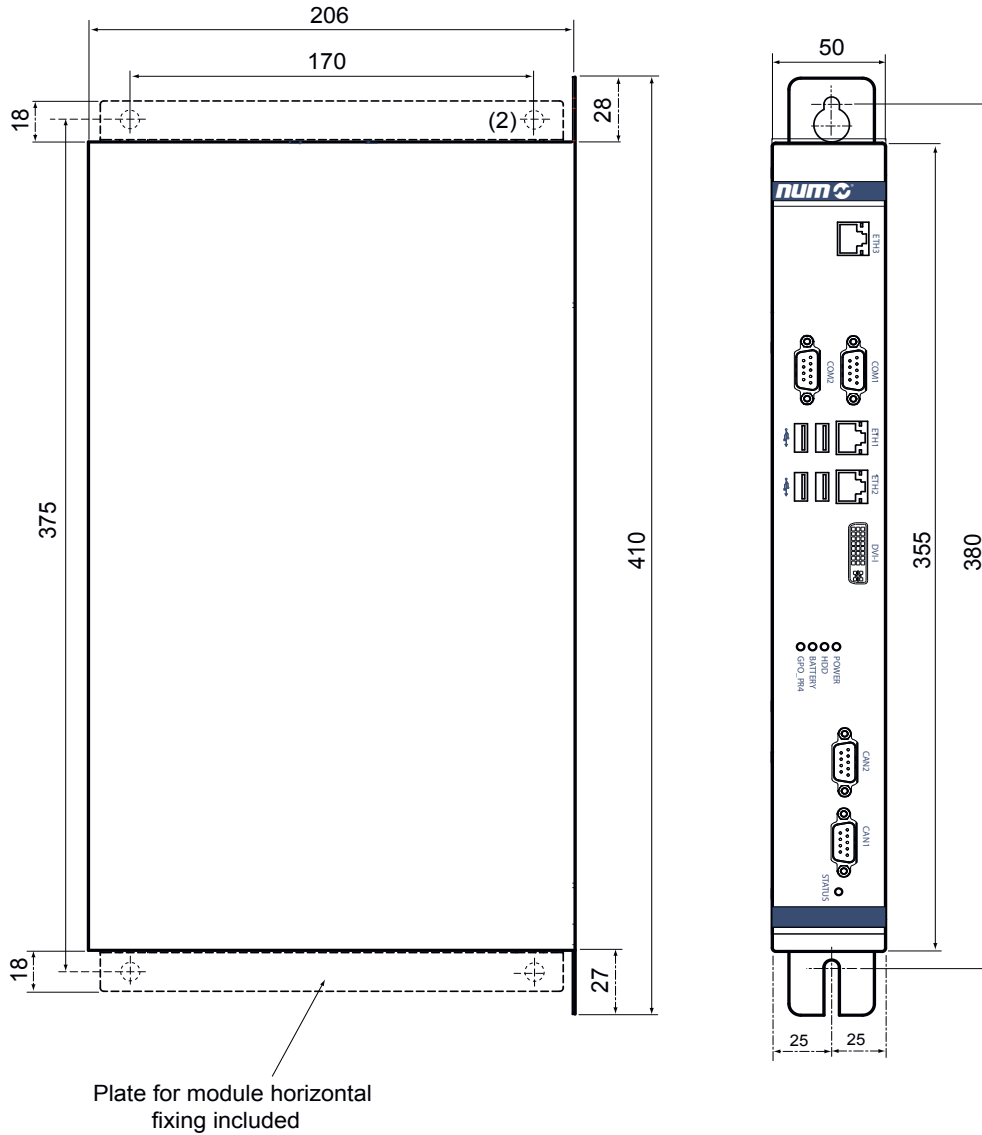

3

Module horizontal fixing

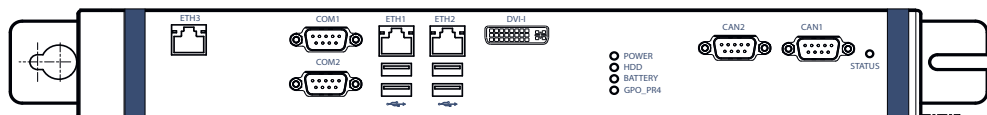

NUM Industrial Box PC P2 Outlines (FXPC004NN2SxR20)

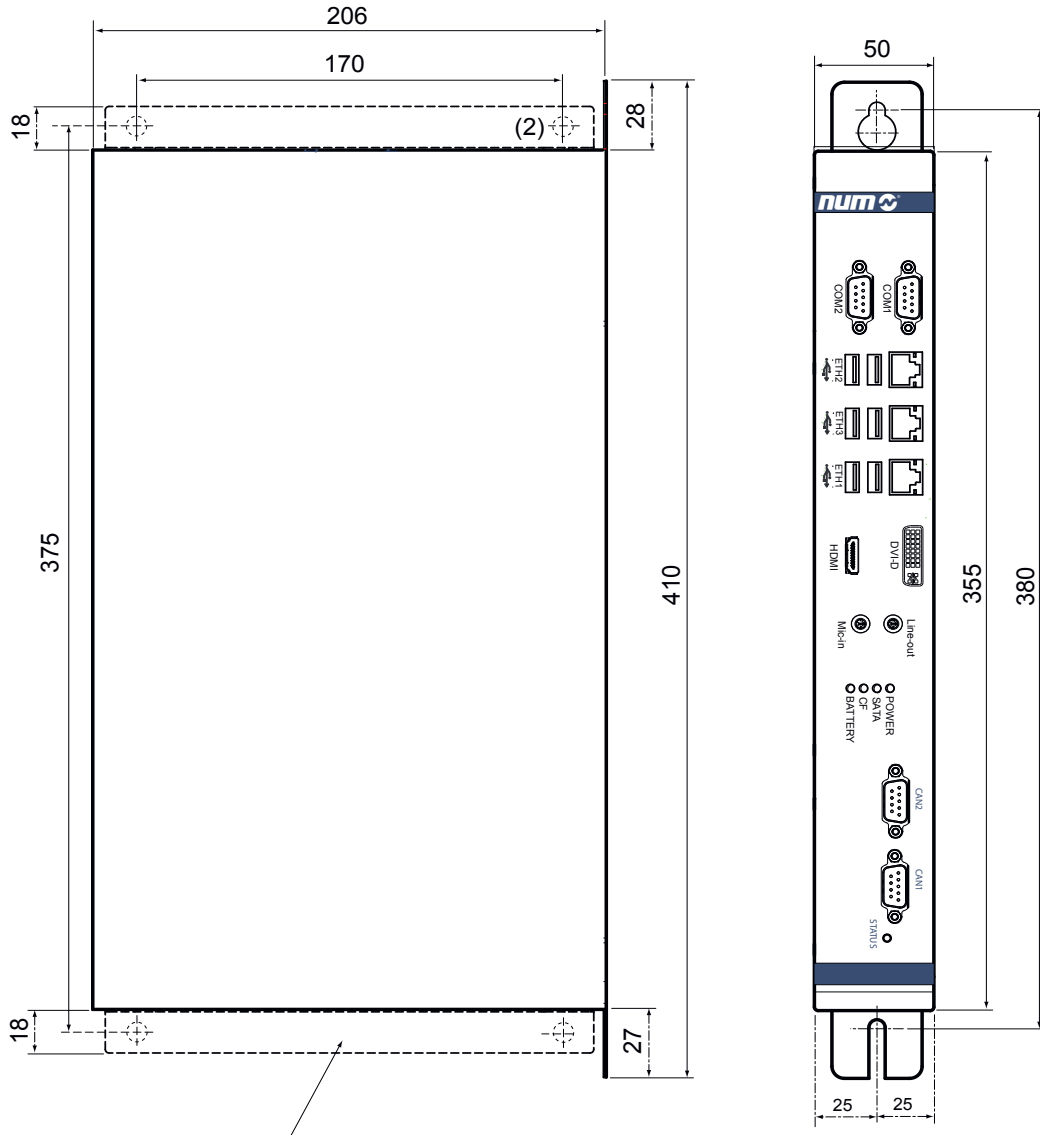
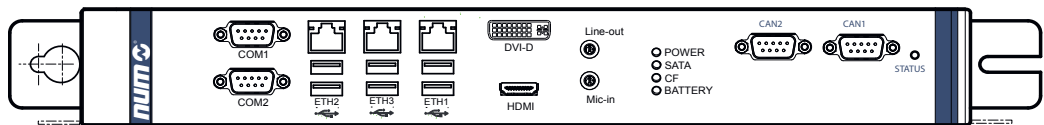

Plate for module horizontal fixing included

Module horizontal fixing





NUM Industrial Box PC Ordering Codes

Box PC Version	Ordering Codes
Box PC P2 G4 SSD RT CAN NVRAM	FXPC004NN2SDR20
Box PC P2 G4 SSD RT	FXPC004NN2SNR20
Box PC P1 G4 HD RT CAN NVRAM	FXPC004NN1HDR10
Box PC P1 G4 HD RT	FXPC004NN1HNR10
Box PC P1 G4 SSD RT CAN NVRAM	FXPZ004NN1SDR10
Box PC P1 G4 SSD RT	FXPZ004NN1SNR10

3

	FXPC	00	4	N	N	1	H	D	R	1	0
Display Unit											
• Industrial Box PC		00									
Panel/Mechanical Variant											
• Fourth generation			4								
Display Sensor											
• No touch sensor, just Box PC				N							
Keyboard Type											
• No keyboard, just Box PC					N						
IPC Mother Board, Processor											
• Performance level P1						1					
• Performance level P2						2					
Mass Memory Type											
• HD (Hard Disk) ¹							H				
• SSD (Solid State Disc)							S				
Option Board											
• No fieldbus									N		
• CAN + NVRAM									D		
Flexium RTS											
• Real time									R		
Operating System											
• Windows 8 kernel ¹										1	
• Windows 10 kernel 64 bits ²										2	
Spare Number											0

¹ For performance level P1 only

² For performance level P2 only

HBA-X Portable Handwheel

HBA-X Portable Handwheel

The HBA-X portable handwheel for Flexium⁺ provides a number of operation functions:

- Axis selection
- Hand mode and speed selection
- Forward/backward movement and speed override
- Handwheel
- 3 step acknowledge button (Enabling Device “dead-man’s button”)
- Connection to the system for Flexium⁺ 6, 8 and 68 via cable and I/O modules
- Buttons and switches: via I/Os
- Handwheel: directly to the Flexium⁺ NCK

Connection to the Flexium⁺ system can be made in two different ways:

- HBA-Xc (5V) FXHE181121
can be connected either directly to the Flexium⁺ NCK or by means of EtherCAT and the terminal CTMT5101
- HBA-Xd (24V) FXHE181122
can be connected by means of EtherCAT and the terminal CTMT5151

CAN

Connection to the Flexium / Flexium⁺ 68 system can also be made using CAN.

This requires one or more CAN connection devices (including a counter module CTMT, see manual M00009) and allows hot-plugging of the HBA-X without affecting the machine. For CAN connectivity the Portable Handwheel HBA-Xd FXHE181122 is recommended.

The connection through EtherCAT allows hot plug-in of the HBA-X device.



HBA-X Portable Handwheel Description

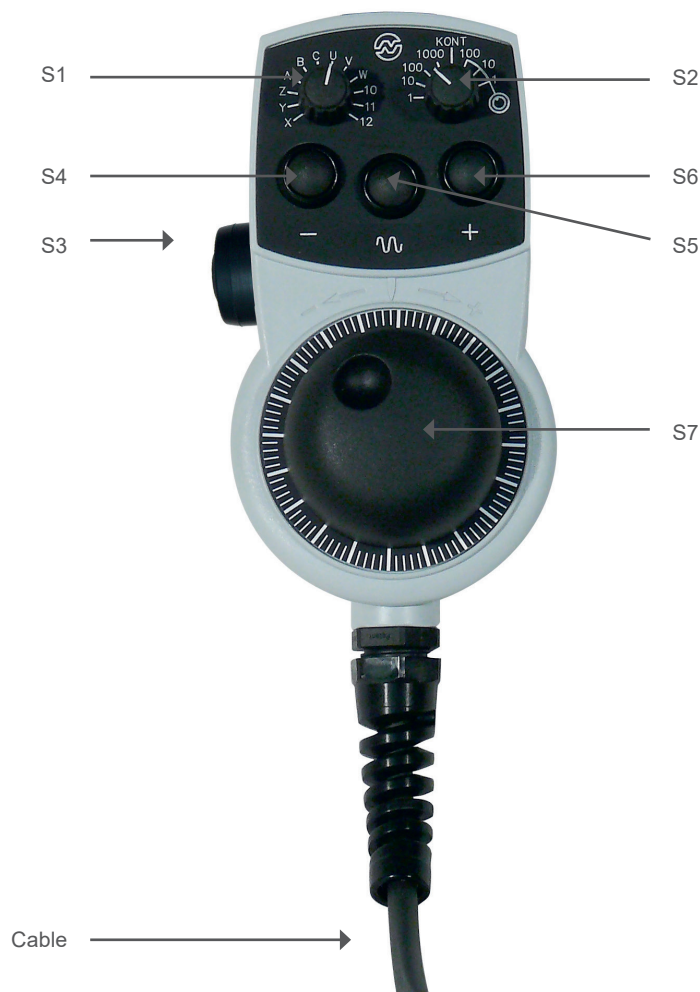

3

S1	Selector switch (12 position axis selection)
S2	Selector switch (8 position incremental selection and rate multiplier)
S3	3 stage acknowledge button Enabling Device (dead-man's button)
S4	Push button (negative)
S5	Push button (fast)
S6	Push button (positive)
S7	Handwheel
Cable	HBA-X cable + plug connector (23 pins M) together with a 23-pin F connector socket

HBA-X Portable Handwheel Technical Characteristics

Handwheel	<ul style="list-style-type: none">• Impulse per revolution: 100• Supply voltage: 5 VDC \pm 5% for HBA-Xc / 24 VDC \pm 5% for HBA-Xd• Output circuit: 5 VDC or 24 VDC
Push Button	<ul style="list-style-type: none">• Control element: 3 single closure• Switching voltage max: 30 VDC• Switching current max: 100mA• Switching power max: 1 W
Acknowledge Button 3-Step	<ul style="list-style-type: none">• Control element: 1 double closure• Switching voltage max: 30 VDC• Switching current max: 1mA• Switching power max: 0.25 W
Connection ^{1,2}	<ul style="list-style-type: none">• 23-pin connector• Cable 5 m
Housing	<ul style="list-style-type: none">• Material: Plastic (polycarbonate)• Colour: Grey RAL 7040• Starting current: 250mA @ 24V• Power consumption: 3.12 W (typ) = 130mA @ 24V• Electrical insulation: No
Overall Dimensions (L, H, W)	160 x 85 x 67 mm
Weight	Approx. 1.3 kg
Temperature	<ul style="list-style-type: none">• Operating temperature: 0 to +50°C• Transport and storage temperature: -20° to +50°C
Relative Humidity	<ul style="list-style-type: none">• Operating: Max 95% non-condensing• Transport: Max 95% non-condensing
Operating Altitude	Max 3000 m
Degree of Protection	IP65

¹ Different OEM handwheel locations may require an additional FXHE181310 socket for connection purposes

² Standard cable length is:
5 m for straight cable

Maximum distance from CNC is 40 m

HBA-X Portable Handwheel Outlines

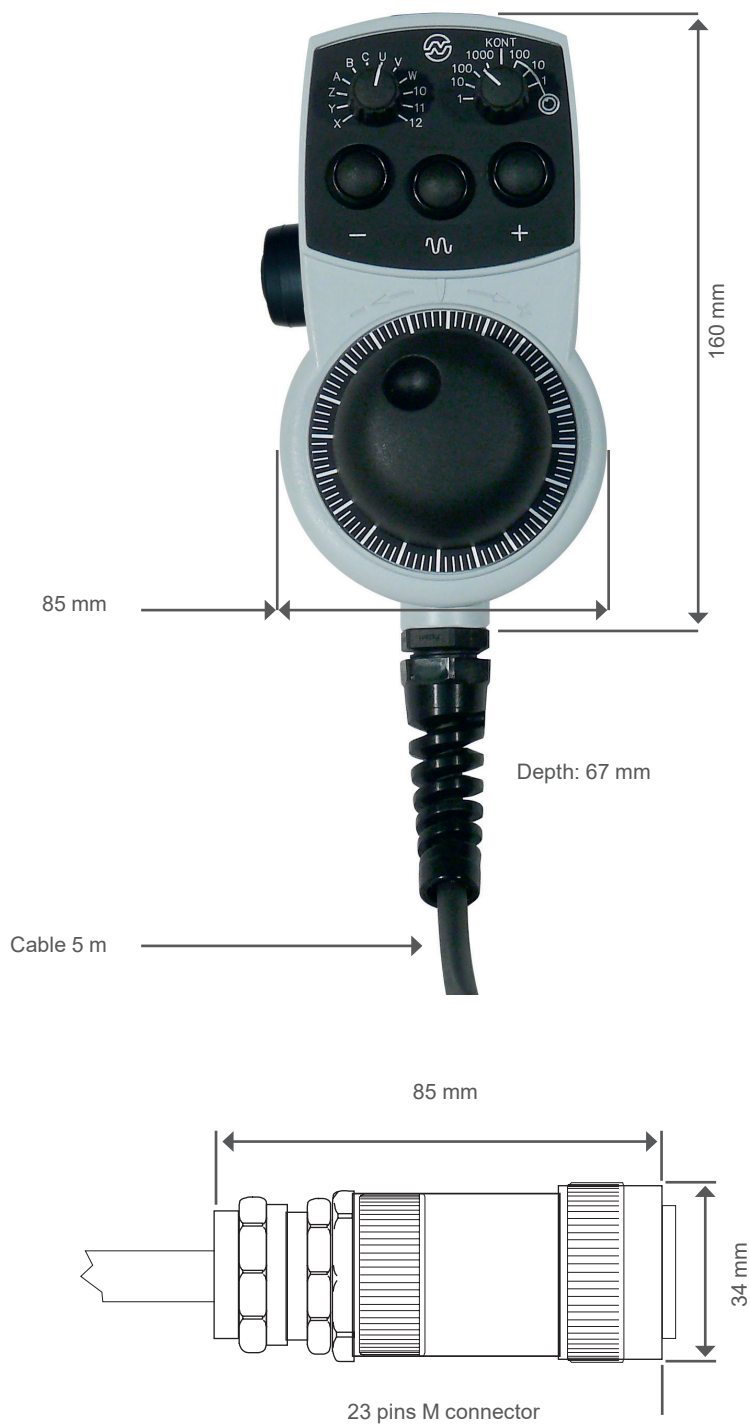

HBA-X Portable Handwheel

Ordering Codes



Portable Handwheel HBA-X Ordering Codes

XBA Version	Ordering Codes
HBA-Xc (5V)	FXHE181121
HBA-Xd (24V)	FXHE181122

Description

Flexium+ NCK

Flexium+ NCK is the heart of a system. In a compact design compatible in size with the NUMDrive X components it packs a powerful engine, up to 40MB of user's memory, the connectivity for up to 32 digital axes or spindles, and the PLC link, all delivered on standard RJ45 ports.

Additional Ethernet and clock synchronization ports for multi-NCK operation, two analog axis ports, two probing inputs as well as sixteen digital inputs, sixteen digital outputs all with direct part program access, four analog inputs and two analog outputs complete this unit.

The Flexium+ NCK (Numerical Control Kernel) is the key unit of the CNC system, which uses the CNC software to manage part programs and machining data, to compute paths and speeds and to monitor axis movements.

CNC units can be linked together in a global configuration, whereby, for example, large transfer systems with more than 200 interpolating axes can be easily implemented.

Integrating machine control panels, inputs and outputs, handwheels, positioning axes and more is easy, thanks to the versatility of the field bus interfaces. The NCK hardware is identical between Flexium+ 6, Flexium+ 8 and Flexium+ 68.

Some features such as analog axes and handwheels require a software option.

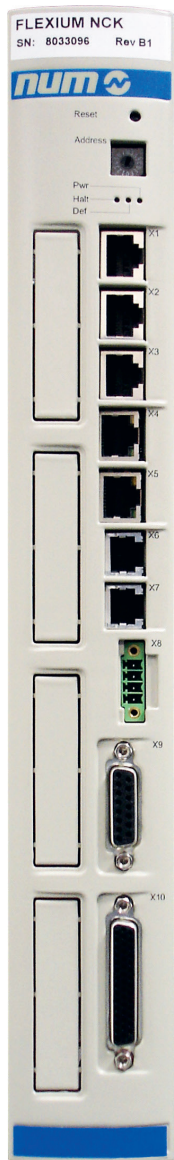

NCK Front View



NCK Top View



NCK Bottom View

NCK Module Description

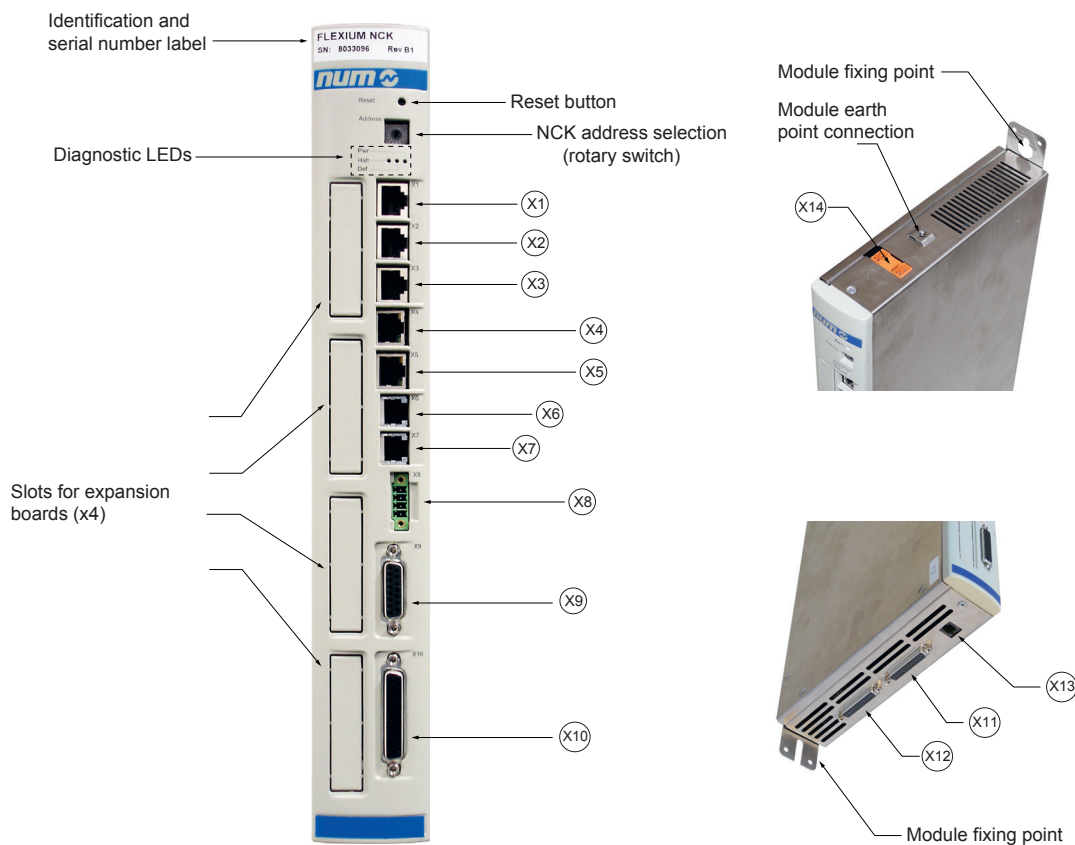

Connector	Description
X1, X2, X3	3 DISC NT+ rings (NCK to NUMDrive X connection)
X4	Do not use
X5	Ethernet port for operator panel FS153 connection
X6	NCK clock output
X7	NCK clock input
X8	Watchdog interface connections: 12VDC/100mA + 30VDC/1A or 250VAC/1A
X9	Analog I/Os: <ul style="list-style-type: none"> • 2 outputs 16 bits +/-10 VDC • 4 inputs 12 bits -10/0...10 VDC
X10	Digital I/Os: 16 inputs 24 VDC, 16 outputs 24 VDC / 1A or Probing 2 inputs 24 VDC
X11	1 Analog axis or Handwheel connections: <ul style="list-style-type: none"> • Reference: ±10 VDC 16 bits
X12	<ul style="list-style-type: none"> • Measure: quadrature complemented incremental encoder with zero pulse
X13	Serial port for debug (internal use only)
X14	Power supply connections: <ul style="list-style-type: none"> • 24 VDC 1A

General Characteristics

Flexium+ NCK		
Power Supply	Rated voltage	24 VDC +20% -15%
	Power consumption	24 VDC (0.5A), 12W
Analog Inputs	4 analog inputs available	
	Input impedance	40kΩ
	Resolution	12 bits
	Input voltage range	0 / +10V
Analog Outputs	2 analog outputs available	
	Output voltage range	- 10V / +10V
	Minimum load	2kΩ
	Resolution	16 bits
Digital Inputs	16 digital input available	
	Rated voltage	24 VDC
	Voltage limits	- 30 to 35 V
	Maximum current	6mA per input
	Operating voltage ranges	<ul style="list-style-type: none"> • Low-level: 0-5 V (current < 1mA) • High-level: 15-30 V (2.8mA < current < 4.3mA)
	Reverse voltage withstand	30 VDC permanent
	Response time	100μs
	Sampling period	2ms
	Logic	Positive (current sink)
Protection	Complying with: IEC 62000-4-5, IEC 61000-4-4, IEC 61000-4-6	
Outputs	16 digital output available	
	Nominal voltage	24 VDC (external power supply)
	Voltage range	15 - 35 VDC
	Maximum internal consumption current	30 mA
	Rated voltage	24 VDC (external power supply)
	Rated current	250 mA per output
	Maximum current (at 40°C maximum)	0.5A per output
	Maximum consumption current	8A for all outputs (protection by fuse)
	Delay on the resistance load (I=0.5 A)	250μs
	Protection per output	Overload and short-circuit (thermal circuit-breaker)
	Protection	by Poly Switch fuse
Digital Inputs for Probing	2 digital inputs available	
	Maximum operational current	2mA
	Minimum current required	1mA
	Input on 24V	<ul style="list-style-type: none"> • Low-level voltage: between 0 and 4.7V • High-level voltage: between 18 and 27V
Analogue Axes	Maximum 2. Please refer to chapter 7 for more detailed information.	
Ambient Conditions	Operating temperature range	0°C to 40°C
	Climatic conditions storage	-25°C to 70°C
	Relative humidity noncondensing	max 75%
Protection Class	IP 20	
Weight	ca. 2.2 kg	
Dimensions	W x H x D	50 x 355 x 206 mm

Flexium+ NCK

Dimensions and Ordering Code

NCK Overall Dimensions

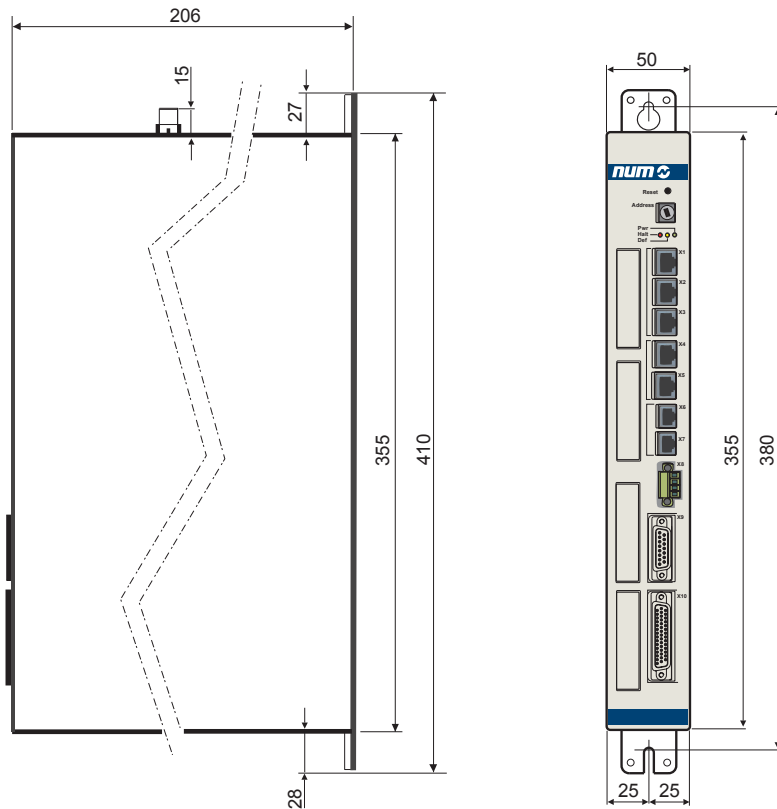

NCK Ordering Code

Flexium+ NCK is included in the Flexium+ 6, Flexium+ 8 and Flexium+ 68 platform.



CTMP6900 - NUMSafe PLC

The NUMSafe PLC controls the Safety PLC program and is connected in the same manner as any other EtherCAT terminal.

The CTMP6900 meets the requirements of IEC 61508 SIL 3 and EN 954 Cat. 4, DIN EN ISO 13849-1:2006 (Cat 4, PL e), NRTL, UL508, UL1998 and UL991.

The NUMSafe PLC has the typical design of an EtherCAT terminal.

For NUMSafe PLC the EtherCAT Safe PLC Option FXSW282305 is required.

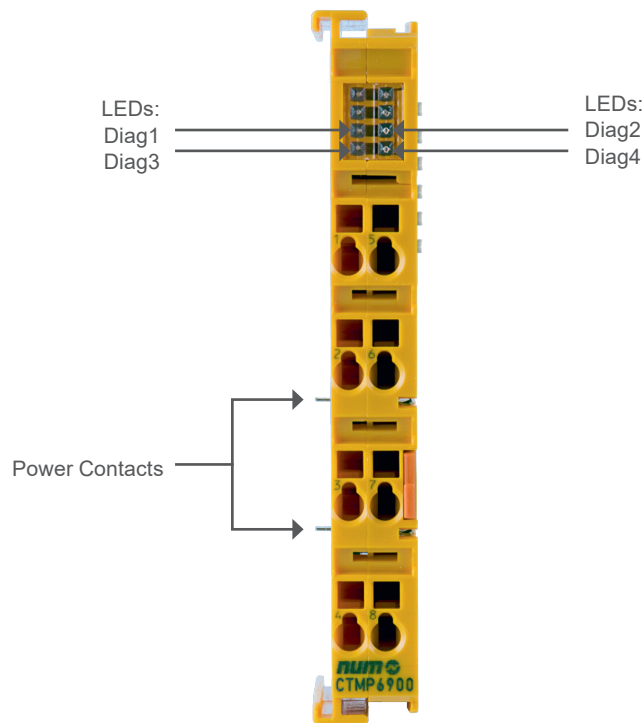



CTMP6900 - Technical Characteristics

Product Name	CTMP6900
Number of Inputs	0
Number of Outputs	0
Status Display	4 diagnostic LEDs
Minimum Cycle Time	Approx. 500µs
Fault Response Time	≤ watchdog times
Watchdog Time	Min. 1ms, max. 60000ms
Input Process Image	Dynamic according to the NUMSafe configuration in "CODESYS Safety for EtherCAT Safety Module" programming system
Output Process Image	Dynamic according to the NUMSafe configuration in "CODESYS Safety for EtherCAT Safety Module" programming system
CTMP6900 Supply Voltage	From NUM EtherCAT Gateway CTMG1100
Current Consumption from the E-Bus	Approx. 188mA
Power Dissipation of the Terminal	Typically 1 W
Dimensions (W x H x D)	12 x 100 x 68 mm
Weight	Approx. 50 g
Permissible Ambient Temperature (Operation)	0°C to +55°C
Permissible Ambient Temperature (Transport / Storage)	-25°C to +70°C
Permissible Air Humidity	5% to 95%, non-condensing
Permissible Air Pressure (Operation / Storage / Transport)	750 hPa to 1100 hPa
Climate Class According to EN 60721-3-3	3K3
Permissible Contamination Level	Contamination level 2
Unacceptable Operating Conditions	NUMSafe terminals must not be used under the following operating conditions: <ul style="list-style-type: none"> • under the influence of ionizing radiation • in corrosive environments • in an environment that leads to unacceptable soiling of the EtherCAT terminal
Vibration / Shock Resistance	Conforms to EN 60068-2-6 / EN 60068-2-27, EN 60068-2-29
EMC Immunity / Emission	Conforms to EN 61000-6-2 / EN 61000-6-4
Shocks	15 g with pulse duration 11 ms in all three axes
Protection Class	IP20
Permitted Operating Environment	Control cabinet or terminal box with minimum protection class IP54 according to IEC 60529
Permissible Installation Position	Please refer to M00032 manual
Approvals	CE, cULus, ATEX

NUMSafe PLC and Safe I/Os

CTMP6900 - NUMSafe PLC
Outlines and Ordering Code



CTMP6900 - Outlines

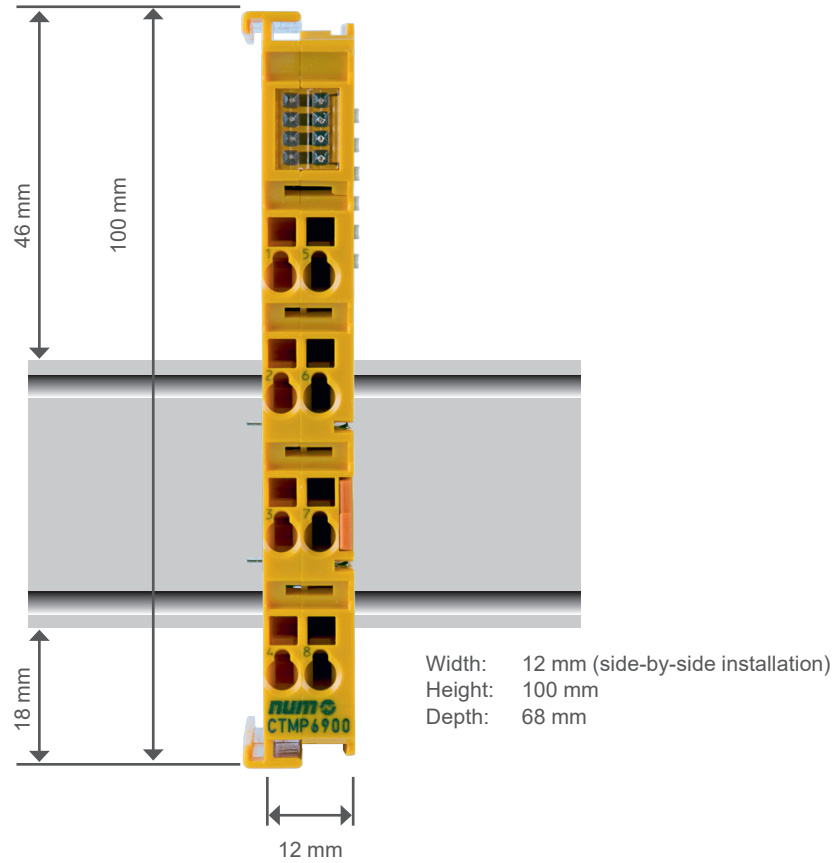

5

CTMP6900 - Ordering Code

Product	Ordering Codes
NUMSafe PLC	CTMP6900



CTMS1904 - NUMSafe Digital Inputs Terminal

The CTMS1904 is a digital input terminal, with floating contacts for 24 VDC.

The EtherCAT terminal has 4 fail-safe inputs.

With two-channel connection, the CTMS1904 meets the requirements of IEC 61508 SIL 3, EN 954, Cat 4, DIN EN ISO 13849-1:2006 (Cat 4, PL e), NRTL, UL508, UL1998 and UL991.

The NUMSafe Digital Inputs Terminal has the typical design of an EtherCAT terminal.

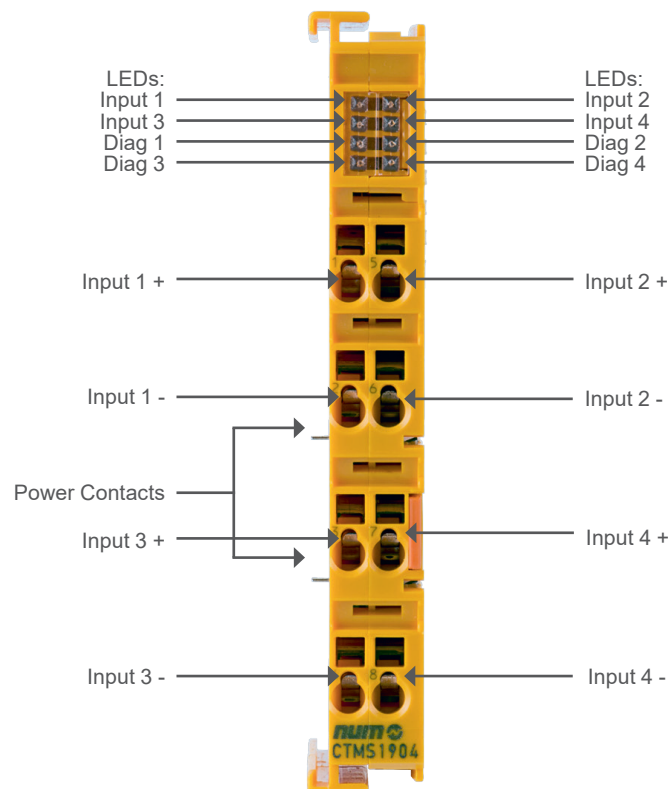

CTMS1904 - Technical Characteristics

Product Name	CTMS1904
Number of Inputs	4
Number of Outputs	0
Response Time (Read Input / Write to E-Bus)	Typically: 4ms, maximum: see fault response time
Fault Response Time	≤ Watchdog time
Cable Length Between Actuator and Terminal (Un-shielded), (Shielded)	100 m max.(at 0.75 or 1 mm ²)
Input Process Image	6 bytes
Output Process Image	6 bytes
CTMS1904 Supply Voltage	From NUM EtherCAT Gateway CTMG1100
Current Consumption of the Modular Electronics at 24V (without Current Consumption of Sensors)	4 channels occupied: typically 12mA 0 channels occupied: typically 1.4mA
Current Consumption from the E-Bus	4 channels occupied: approx. 200mA
Power Dissipation of the Terminal	Typically 1 W
Electrical Isolation (Between the Channels)	No
Electrical Isolation (Between the Channels and the E-Bus)	Yes
Insulation Voltage (Between the Channels and the E-Bus, Under Common Operating Conditions)	Insulation tested with 500 VDC
Dimensions (W x H x D)	12 x 100 x 68 mm
Weight	Approx. 50 g
Permissible Ambient Temperature (Operation)	0°C to +55°C
Permissible Ambient Temperature (Transport / Storage)	-25°C to +70°C
Permissible Air Humidity	5% to 95%, non-condensing
Permissible Air Pressure (Operation / Storage / Transport)	750 hPa to 1100 hPa
Climate Class According to EN 60721-3-3	3K3
Permissible Contamination Level	Contamination level 2
Unacceptable Operating Conditions	NUMSafe terminals must not be used under the following operating conditions: <ul style="list-style-type: none"> • under the influence of ionizing radiation • in corrosive environments • in an environment that leads to unacceptable soiling of the EtherCAT Terminal
Vibration / Shock Resistance	Conforms to EN 60068-2-6 / EN 60068-2-27, EN 60068-2-29
EMC Immunity / Emission	Conforms to EN 61000-6-2 / EN 61000-6-4
Shocks	15 g with pulse duration 11ms in all three axes
Protection Class	IP20
Permitted Operating Environment	Control cabinet or terminal box with minimum protection class IP54 according to IEC 60529
Permissible Installation Position	Please refer to M00032 manual
Approvals	CE, cULus, ATEX

NUMSafe PLC and Safe I/Os

CTMS1904 - NUMSafe Digital Inputs Terminal
Outlines and Ordering Code



CTMS1904 - Outlines

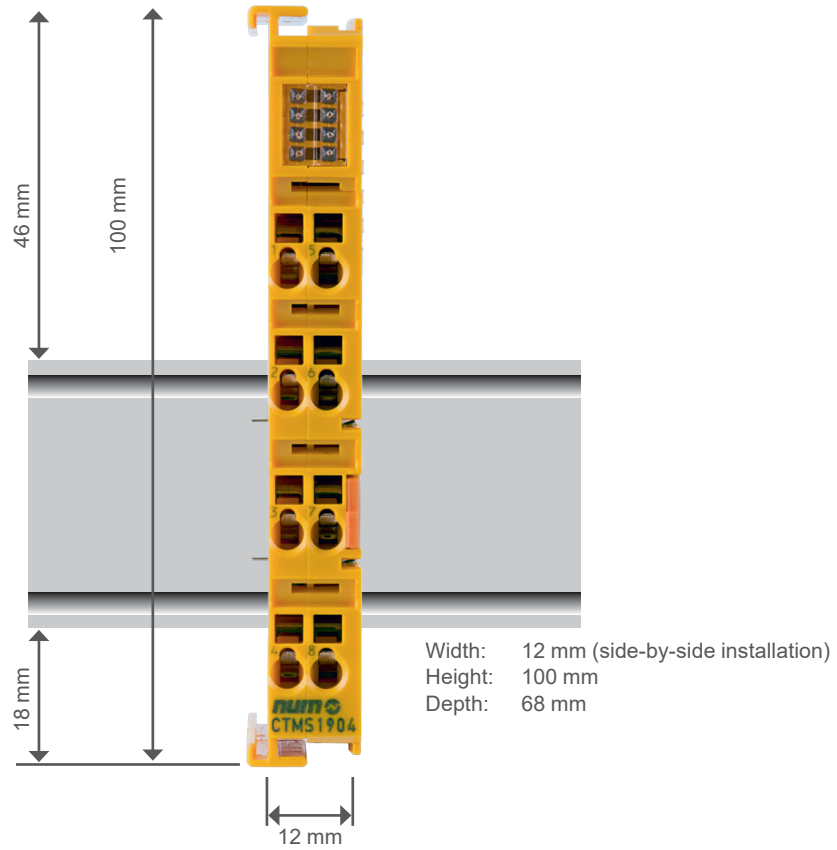

CTMS1904 - Ordering Code

Product	Ordering Codes
4 channels NUMSafe Digital Inputs Terminal	CTMS1904



CTMS2904 - NUMSafe Digital Outputs Terminal

The CTMS2904 is a safe output terminal with digital outputs for connecting actuators (contactors, relays, etc.) with a maximum current 0.5A (24 VDC).

The EtherCAT terminal has 4 fail-safe outputs.

The CTMS2904 meets the requirements of IEC 61508 SIL 3, EN 954 Cat 4, DIN EN ISO 13849-1:2006 (Cat 4, PL e), NRTL, UL508, UL1998 and UL991.

The NUMSafe Digital Outputs Terminal has the typical design of an EtherCAT terminal.

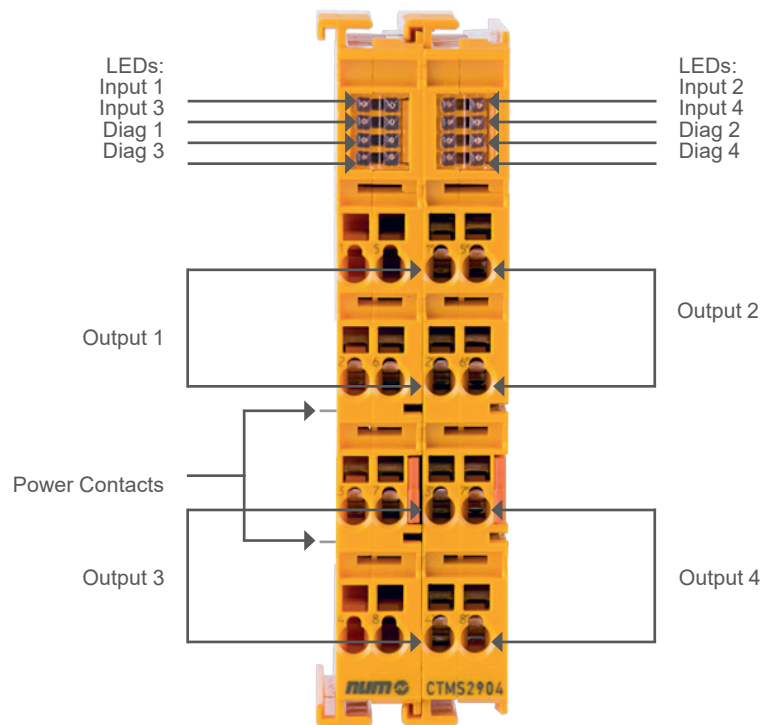

CTMS2904 - Technical Characteristics

Product Name	CTMS2904
Permissible Contamination Level	0
Number of Outputs	4
Status Display	4 (one green LED per output)
Fault Response Time	≤ Watchdog times
Output Current per Channel	Max. 500mA, min. 20mA with current measurement active
Actuators	When selecting actuators please ensure that the CTMS2904 test pulses do not lead to actuator switching
Cable Length Between Actuator and Terminal (Unshielded), (Shielded)	Max. 100 m
Wire Cross Section	Min. 0.75 mm ²
Input Process Image	6 bytes
Output Process Image	6 bytes
CTMS2904 Supply Voltage	From NUM EtherCAT Gateway CTMG1100
Current Consumption from the E-Bus	Approx. 221mA
Power Dissipation of the Terminal	Typically 2 W
Electrical Isolation (Between the Channels)	No
Electrical Isolation (Between the Channels and the E-Bus)	Yes
Insulation Voltage (Between the Channels and the E-Bus, Under Common Operating Conditions)	Insulation tested with 500 VDC
Dimensions (W x H x D)	24 x 100 x 68 mm
Weight	Approx. 100 g
Permissible Ambient Temperature (Operation)	0°C to +55°C
Permissible Ambient Temperature (Transport / Storage)	-25°C to +70°C
Permissible Air Humidity	5% to 95%, non-condensing
Permissible Air Pressure (Operation / Storage / Transport)	750 hPa to 1100 hPa
Climate Class According to EN 60721-3-3	3K3
Permissible Contamination Level	Contamination level 2
Unacceptable Operating Conditions	NUMSafe terminals must not be used under the following operating conditions: <ul style="list-style-type: none"> • under the influence of ionizing radiation • in corrosive environments • in an environment that leads to unacceptable soiling of the EtherCAT terminal
Vibration / Shock Resistance	Conforms to EN 60068-2-6 / EN 60068-2-27, EN 60068-2-29
EMC Immunity / Emission	Conforms to EN 61000-6-2 / EN 61000-6-4
Shocks	15 g with pulse duration 11ms in all three axes
Protection Class	IP20
Permitted Operating Environment	Control cabinet or terminal box with minimum protection class IP54 according to IEC 60529
Permissible Installation Position	Please refer to M00032 manual
Approvals	CE, cULus, ATEX

NUMSafe PLC and Safe I/Os

CTMS2904 - NUMSafe Digital Outputs Terminal Outlines and Ordering Code



CTMS2904 - Outlines

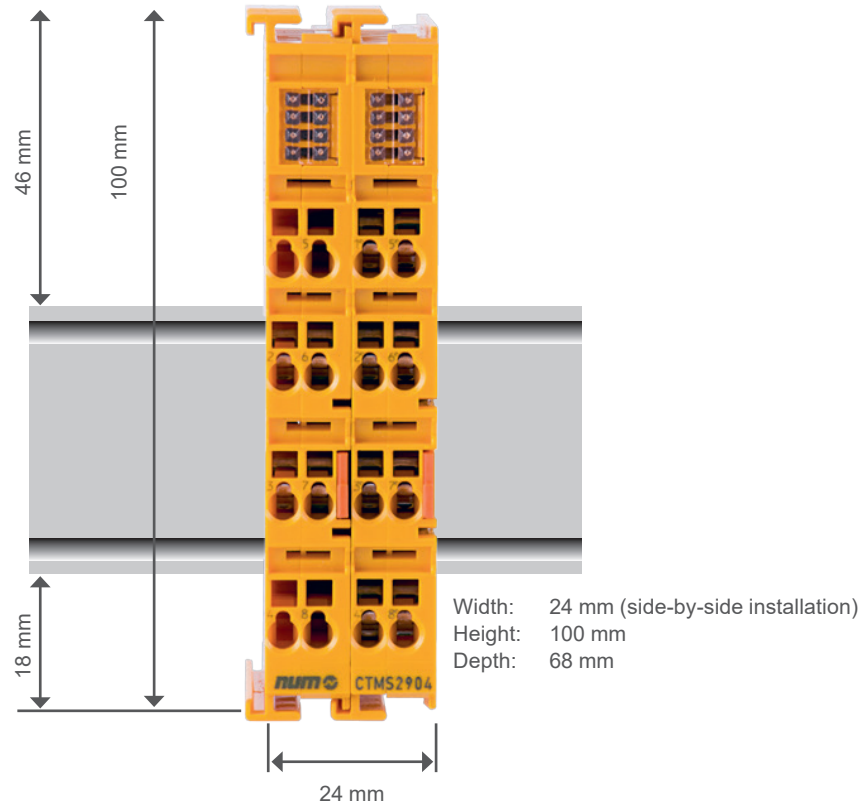

5

CTMS2904 - Ordering Code

Product	Ordering Codes
4 channels NUMSafe Digital Outputs Terminal	CTMS2904



CTMS2912 - NUMSafe Digital Outputs Terminal

The CTMS2912 is a safe output terminal with digital outputs for connecting actuators (contactors, relays, etc.) with a maximum current 2A (24 VDC).

The EtherCAT terminal has 2 fail-safe outputs.

The CTMS2912 meets the requirements of IEC 61508 SIL 3, EN 954 Cat 4, DIN EN ISO 13849-1:2006 (Cat 4, PL e).

The NUMSafe Digital Outputs Terminal has the typical design of an EtherCAT terminal.

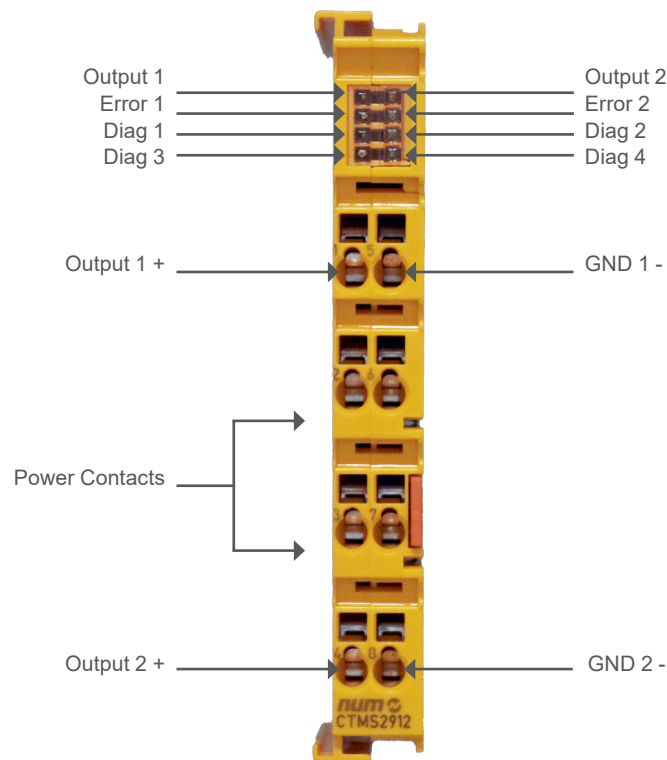

CTMS2912 - Technical Characteristics

Product Name	CTMS2912
Number of outputs	2
Status display	4 (one green and one red LED for each output)
Fault response time	≤ watchdog times
Output current per channel	max. 2 A (at 24 VDC)
Actuators.	When selecting actuators please ensure that the CTMS2912 test pulses do not lead to actuator switching
Cable length between actuator and terminal	Unshielded max. 100 m Shielded max. 100 m
Wire cross section	min. 0.75 mm ²
Input process image	6 bytes
Output process image	6 bytes
CTMS2912 supply voltage (SELV/PELV)	24 VDC (-15% / +20%) (A 10 A fuse should be provided for the potential group)
Current consumption from the E-bus	Approx. 200 mA
Power dissipation of the terminal	Typically 1.7 W
Electrical isolation (between the channels)	No
Electrical isolation (between the channels and the E-bus)	Yes
Insulation voltage (between the channels and the E-bus, under common operating conditions)	Insulation tested with 500 VDC
Dimensions (W x H x D)	12 mm x 100 mm x 68 mm
Weight	Approx. 55 g
Permissible ambient temperature (operation)	-25 °C to +55 °C (note chapter Temperature measurement)
Permissible ambient temperature (transport/storage)	-40 °C to +85 °C
Permissible air humidity	5% to 95%, non-condensing
Permissible air pressure (operation/storage/transport)	750 hPa to 1100 hPa (this corresponds to an altitude of approx. -690 m to 2450 m above sea level, assuming an international standard atmosphere)
Climate category according to EN 60721-3-3	3K3 (the deviation from 3K3 is possible only with optimal environmental conditions and also applies only to the technical data which are specified differently in this documentation)
Permissible level of contamination according to EN 60664-1	level of contamination 2 (note chapter Maintenance)
Unacceptable operating conditions	NUMSafe Terminals must not be used under the following operating conditions: <ul style="list-style-type: none"> • under the influence of ionizing radiation (exceeding the natural background radiation) • in corrosive environments • in an environment that leads to unacceptable soiling of the Bus Terminal
EMC immunity/emission	Conforms to EN 61000-6-2 / EN 61000-6-4 (EMC Zone B)
Vibration resistance	Conforms to EN 60068-2-6 5 Hz ≤ f < 8.4 Hz (3.5 mm peak) 8.4 Hz ≤ f < 150 Hz (10 m/s ² peak)
Shock resistance	conforms to EN 60068-2-27 15 g with pulse duration 11 ms in all three axes
Protection class	IP20
Permitted operating environment	In the control cabinet or terminal box, with minimum protection class IP54 according to IEC 60529
Permissible installation position	See chapter Installation position and minimum distances
Approvals	CE, TÜV SÜD

NUMSafe PLC and Safe I/Os

CTMS2912 - NUMSafe Digital Outputs Terminal Outlines and Ordering Code



CTMS2912 - Outlines

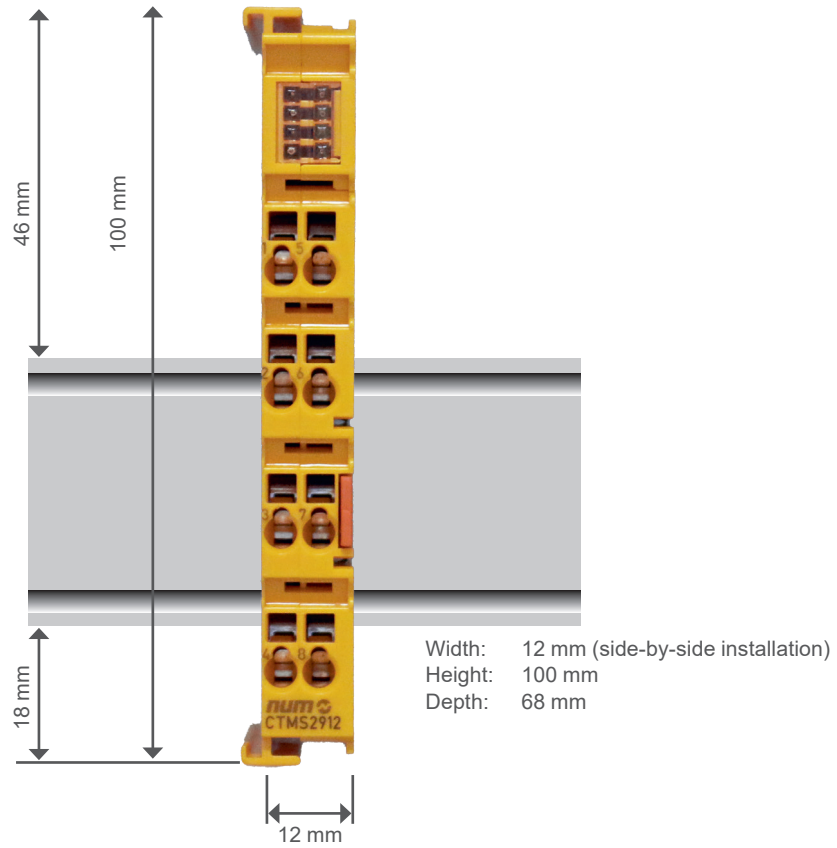

CTMS2912 - Ordering Code

Product	Ordering Codes
2 channels NUMSafe Digital Outputs Terminal, 24V DC 2A	CTMS2912

NUMSafe PLC and Safe I/Os

CTMP1960-2600 - NUMSafe Compact Controller

CTMP1960-2600 - NUMSafe Compact Controller

NUMSafe Compact Controller CTMP1960-2600, the all-in-one solution for safety applications. It integrates an EtherCAT gateway, a complete safety controller including I/O with 20 safe digital inputs, 24 safe digital outputs and 4 potential-free contacts (NO).

Thanks to its design, with 20 safe digital inputs and 24 safe digital outputs, it covers the complete safety requirements for compact machines. The CTMP1960-2600 can be operated in stand-alone mode or it can be networked with other controllers over the EtherCAT connectors. Like every EtherCAT gateway, the CTMP1960-2600 can be extended with all CTMT/CTMS terminals by means of a CTMT9100, at least.

The NUMSafe Compact Controller is programmed via Flexium Tools (Safety Editor) in the same way as other NUMSafe components.

The device is TÜV Süd certified; it's suitable for applications up to SIL 3 according to EN 61508:2010 and Cat 4, PL e according to EN ISO 13849-1:2015.

For NUMSafe Compact controller the EtherCAT Safe PLC Option FXSW282305 is required.

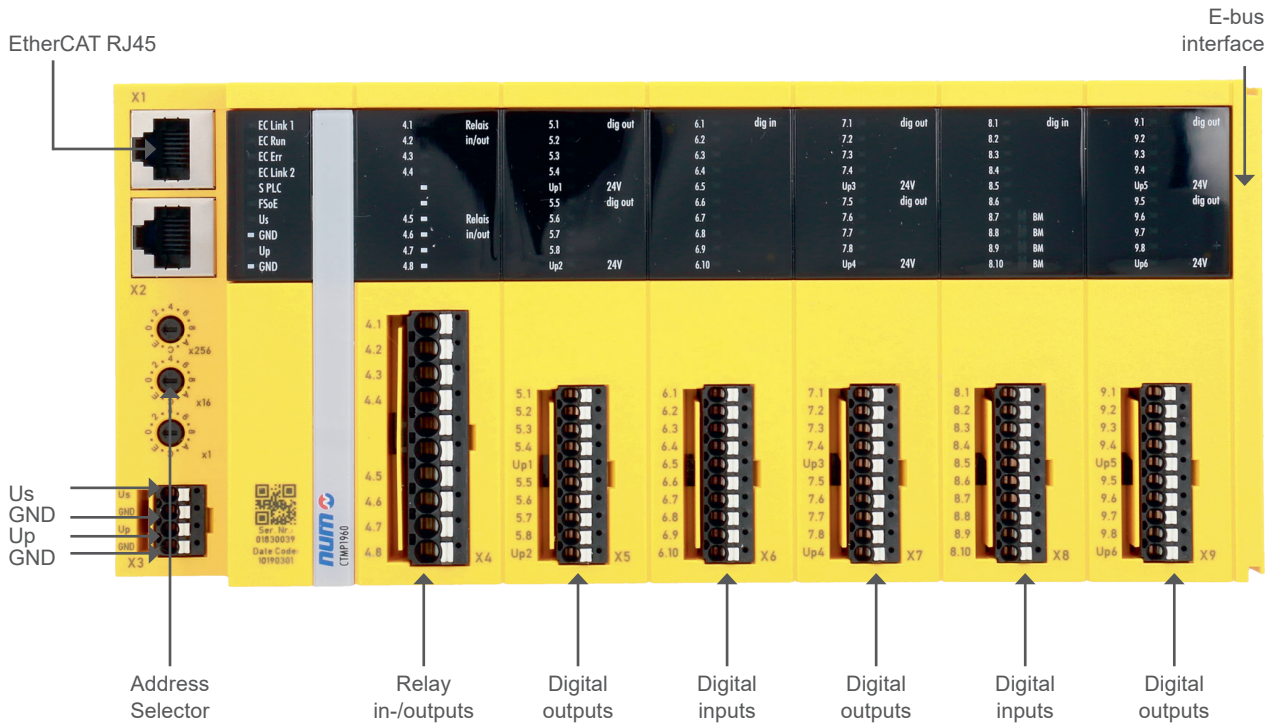



CTMP1960-2600 - Technical Characteristics

Product Name	CTMP1960-2600
Technology	NUMSafe Compact Controller
Distance between stations	100 m (100BASE-TX)
Number of EtherCAT Terminals	up to 65,534
Bus interface	2 x RJ45
Safety standard	EN ISO 13849-1:2015 (Cat 4, PL e) and EN 61508:2010 (SIL 3)
Number of communication partners	max. 128
Protocol	EtherCAT
Safety protocol	Safety over EtherCAT
Function blocks	Max. 512 (ESTOP with complete input and output mapping)
Nominal voltage	24 VDC (-15 %/+20 %)
E-bus power supply (5 V)	max. 500 mA (In the case of higher current consumption, please use the CTMT9410 power feed terminals in addition!)
Cycle time	< 10 ms
Response time	dependent on application (< 15 ms)
Fault response time	≤ watchdog time (parameterizable)
Connection method	1-wire
Number of inputs	20
Number of outputs	24 (6 module with 4 outputs each)
Number of potential free (NO) outputs	4
Max. output current	2 A (simultaneity factor 50 % at 2 A) for each module
Dimensions (W x H x D)	230.5 mm x 100 mm x 58.6 mm
Permitted degree of contamination	2
Climate class EN 60721-3-3	3K3
Operating/storage temperature	-25...+55 °C/-40...+70 °C
EMC immunity/emission	conforms to EN 61000-6-2/EN 61000-6-4
Vibration/shock resistance	conforms to EN 60068-2-6/EN 60068-2-27
Protect. class/installation pos.	IP 20/horizontal
Approvals	CE, TÜV SÜD

NUMSafe PLC and Safe I/Os

CTMP1960-2600 - NUMSafe Compact Controller

Outlines and Ordering Code



CTMP1960-2600 - Outlines

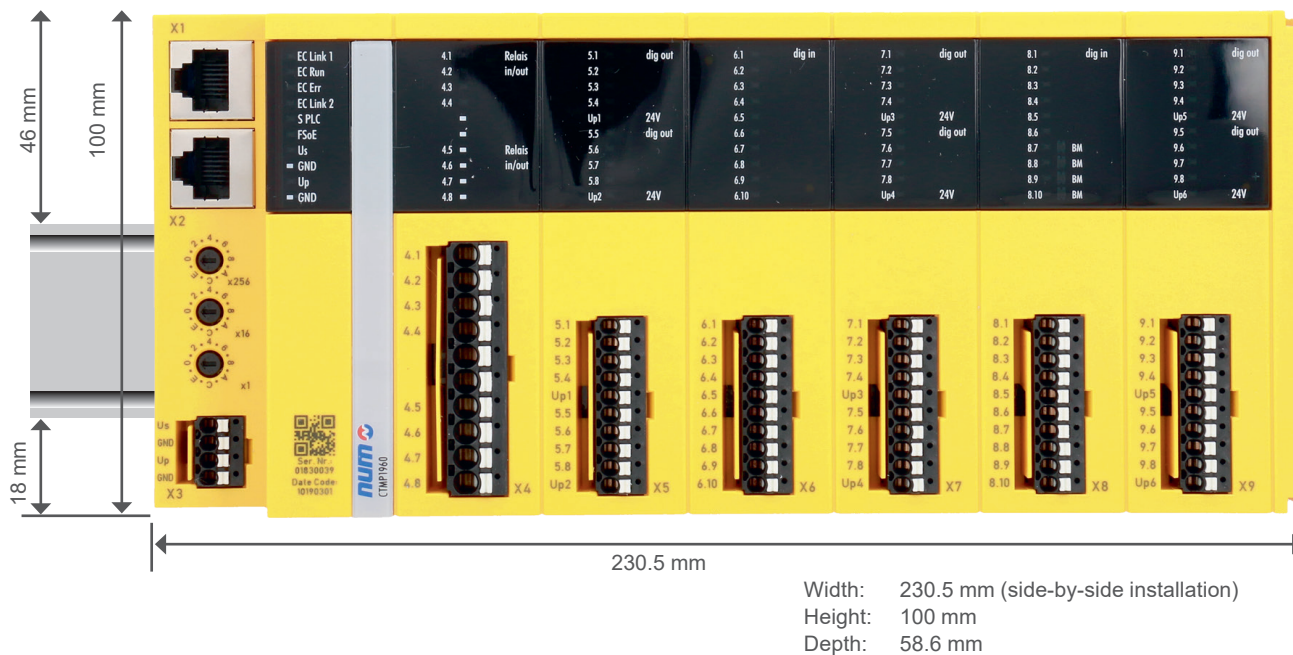

5

CTMP1960-2600 - Ordering Code

Product	Ordering Codes
NUMSafe Compact Controller	CTMP1960-2600



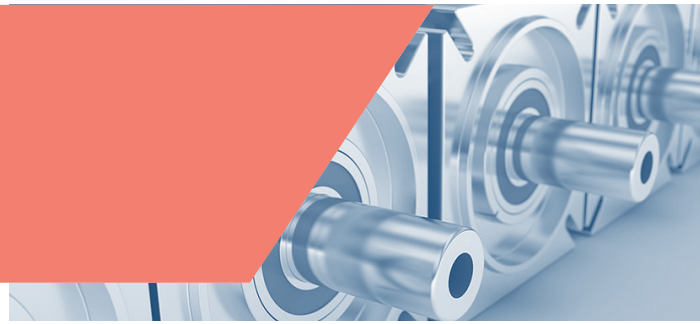

Overview and Product Positioning

NUM manufactures a comprehensive range of motors, all featuring high power-to-weight ratios and excellent dynamic range. Availability of a vast variety of motors enables NUM to provide solutions that are perfectly tailored to each application.

In conjunction with NUMDrive servo drives these motors offer excellent stability even at very low rotational speeds.

NUM motors are equipped with robust optical encoders of different resolution/accuracy levels to fit the requirements of the machine and the application.

Developed for use with NUM's latest-generation NUMDrive X digital servo drives and Flexium⁺ CNC platform, our innovative SHX and SPX brushless servomotors only require a single cable connection, providing major savings by eliminating the need for a separate encoder cable. Machine builders can now use a single drive-to-motor cable for each motion axis, thereby reducing cabling, speeding installation/commissioning, and improving system performance.

An innovative embedded digital interface scheme allows the encoder power and position feedback data – together with diagnostic information and thermal data from the motor's temperature sensor – to be carried on just two shielded wires contained within the motor's power cable. This approach has significant advantages for machine builders. In addition to lower cabling costs, cable chains are smaller and lighter, the onerous task of installing and debugging cable runs is much less time consuming, and the reduced number of interconnections improves reliability and immunity to electromagnetic interference.

NUM also offers a wide choice of built-in and liquid-cooled motors, including custom designed models. For details about any of these types of motors, please contact your local NUM sales office.



Product Positioning

The different motor ranges are positioned as shown in the table below:

Motor Range	Main Characteristics	Typical Applications	Cont. Torque / Power Range	Available Sizes	Available Options
SHX	Single cable servomotor with very compact design, medium inertia, IP64	Designed for feeding axes of cost sensitive machine tools	From 1.2 Nm up to 20 Nm	Frame sizes 75 mm 95 mm 126 mm 155 mm	Holding brake Keyed shaft Medium and high resolution single/multi turn encoder High inertia version
SPX	Single cable servomotor with extremely compact design, high peak torques, smooth operation, medium inertia, IP67	Designed for feeding axes of high-end machine tools, grinding machines, robotics and special machines	From 0.5 Nm up to 23 Nm	Frame sizes 75 mm 95 mm 126 mm 155 mm	Holding brake Keyed shaft Medium and high resolution single/multi turn encoder High inertia version
BHX	Very compact design, medium inertia, IP64 servomotor	Designed for feeding axes of cost sensitive machine tools	From 1.2 Nm up to 20 Nm	Frame sizes 75 mm 95 mm 126 mm 155 mm	Holding brake Keyed shaft Medium and high resolution single/multi turn encoder High inertia version
BPX	Extremely compact design, high peak torques, smooth operation, medium inertia, IP67 servomotor	Designed for feeding axes of high-end machine tools, grinding machines, robotics and special machines	From 0.5 Nm up to 23 Nm	Frame sizes 55 mm 75 mm 95 mm 126 mm 155 mm	Holding brake Keyed shaft Medium and high resolution single/multi turn encoder High inertia version
BPH	Compact design, smooth operations, medium inertia, up to IP67 servomotor	Designed for feeding axes of high-end machine tools, grinding machines, robotics and special machines	From 1.3 Nm up to 100 Nm	Frame sizes 75 mm 95 mm 115 mm 142 mm 190 mm	Holding brake Keyed shaft Medium and high resolution single/multi turn encoder IP67 degree of protection
BPG	Compact design, smooth operation, very high inertia, up to IP67 servomotor	Designed for feeding axes of high end machine tools, grinding machines, robotics and special machines	From 1.3 Nm up to 56 Nm	Frame sizes 75 mm 95 mm 115 mm 142 mm 190 mm	Keyed shaft Medium and high resolution single/multi turn encoder IP67 degree of protection
BHL	Very compact design, high inertia, IP64 servomotor	Designed for feeding axes of large machine tools	From 85 Nm up to 160 Nm	Frame sizes 260 mm	Holding brake Keyed shaft Medium and high resolution single/multi turn encoder
TMX	Torque motor	Designed for direct drives	From 33 Nm up to 325 Nm	Stator diameter 140 mm 210 mm 291 mm	None
AMS/IM	Compact fan cooled spindle motor	Designed for main spindles	From 2.2 kW up to 55 kW	Shaft height 100 mm 132 mm 160 mm 180 mm	Keyed shaft High resolution single/multi turn encoder Low vibration level High radial loads



Product Positioning

Motor Range	Front	Profile	Lateral
SHX			
SPX			
BHX			
BPX			
BPH			
TMX			
AMS			



General Characteristics

BHX and SHX servomotors are very compact medium inertia units, designed for the feeding axes of cost sensitive machine tools. They are available in 75 mm, 95 mm, 126 mm and 155 mm frame sizes, with a variety of options.

SHX servomotors are mechanically identical to BHX servomotors and have the same basic characteristics. However, thanks to an innovative encoder protocol, SHX servomotors only require a single cable to connect with NUMDrive X drives.

General Motor Features	As per EN60034-1
Environment Storage Conditions • Temperature Range • Relative Humidity	-20 to +80 °C max. 80% without condensation
Environment Working Conditions • Temperature Range • Altitude	0 to 40 °C without derating, max. 55 °C with derating 0 to 1000 m without derating, max. 3000 m with derating
Continuous Stall Torque Range	From 1.2 to 20 Nm
Degree of protection as per EN60529	Housing IP64, shaft IP54
Connection	By rotary connector
Permanent Magnet Holding Brake	24 VDC available as option (excluding for high inertia version)
Motor Transducer	High resolution single turn and multi turn optical encoder Medium resolution single turn and multi turn optical encoder Medium resolution single turn and multi turn optical encoder 2 wires (for SHX only) Medium resolution single turn and multi turn optical encoder 2 wires SIL 2 (for SHX only)
Mounting Restriction	No mounting restrictions, IMB5 - IMV1 - IMV3 as per EN60034-7
Finishing	Not painted, dielectric varnish only

Technical Characteristics

For peak torque figures please refer to chapter 7 where the drive-motor associations are described.

BHX SHX	Low speed continuous torque	Rated speed	Rotor Inertia			Motor weight			Brake		Low speed continuous current	Dimensioning Power
			without brake	with brake	high inertia version	without brake	with brake	high inertia version	Torque	Current		
	[Nm]	[rpm]	[g.m ²]	[g.m ²]	[g.m ²]	[kg]	[kg]	[kg]	[Nm]	[A]	[Arms]	[kW]
0751V5...	1.2	6 000	0.07	0.08	0.12	2.1	2.3	2.4	2.2	0.4	1.7	0.75
0752V5...	2.1	6 000	0.13	0.14	0.18	3.1	3.3	3.4			3.1	1.32
0951V5...	2.4	6 000	0.20	0.26	0.54	3.4	4.1	4.3	6.0	0.7	3.0	1.51
0952N5...	4.3	3 000	0.37	0.43	0.71	4.8	5.5	5.7			2.8	1.35
0952V5...		6 000							5.6	2.70		
1261N5...	4.5	3 000	0.55	0.69	1.49	5.5	7.0	7.2	13.0	0.8	3.2	1.41
1261V5...		6 000									6.4	2.83
1262N5...	8.4	3 000	1.07	1.21	2.01	8.0	9.5	9.7	13.0	0.8	6.0	2.64
1262V5...		6 000									12.0	5.28
1263R5...	11.0	4 500	1.58	1.72	2.52	10.6	12.1	12.3	29.0	0.9	10.0	5.18
1552N5...	12.0	3 000	2.45	2.86	5.25	11.6	13.8	14.3			7.5	3.80
1552R5...		4 500							10.2	5.70		
1554N5...	20.0	3 000	4.76	5.17	7.56	18.2	20.4	20.9	29.0	0.9	12.4	6.30



BHX Servomotor Ordering Codes

	BHX	075	1	V	5	Q	A	2	L	0	0
Series											
Size (075, 095, 126, 155)											
Length											
Winding type											
Connection type											
• Standard right-angled M23 rotatable connectors	5										
Sensor type											
• High resolution multi-turn encoder	P										
• High resolution single-turn encoder	Q										
• Medium resolution multi-turn encoder	J										
• Medium resolution single-turn encoder	K										
Brake											
• Without brake	A										
• With brake	F										
• High inertia version ¹	G										
Version											
• Standard	2										
Shaft extension											
• Smooth	L										
• Keyed	C										
Type of customization											
• Standard	0										
Degree of protection (shaft extension/frame)											
• IP 54/64	0										

¹ Brake option not available



SHX Servomotor Ordering Codes

	SHX	075	1	V	5	Y	A	2	L	0	0
Series											
Size (075, 095, 126, 155)											
Length											
Winding type											
Connection type											
• Standard right-angled M23 rotatable connectors					5						
Sensor type											
• High resolution multi-turn encoder 2-wires						Y					
• High resolution single-turn encoder 2-wires						Z					
• Medium resolution multi-turn encoder 2-wires						I					
• Medium resolution single-turn encoder 2-wire						L					
Brake											
• Without brake							A				
• With brake							F				
• High inertia version ¹							G				
Version											
• Standard								2			
Shaft extension											
• Smooth									L		
• Keyed									C		
Type of customization											
• Standard										0	
Degree of protection (shaft extension/frame)											
• IP54/64											0

¹ Brake option not available

BHX & SHX Servomotor Outlines

See pages 184-186 for BHX, SHX, BPX & SPX servomotor outlines.



General Characteristics

BPX and SPX servomotors are extremely compact medium inertia units with a high peak torque capability, designed for the feeding axes of high-end machine tools, grinding machines, robotics and special machines. They are available in 55 mm, 75 mm, 95 mm, 126 mm and 155 mm frame sizes, with a variety of options. SPX servomotors are mechanically identical to BPX servomotors and have the same basic characteristics. However, thanks to an innovative encoder protocol, SPX servomotors only require a single cable to connect with NUMDrive X drives.

General Motor Features	As per EN60034-1
Environment Storage Conditions • Temperature Range • Relative Humidity	-20 to +80 °C max. 80% without condensation
Environment Working Conditions • Temperature Range • Altitude	0 to 40 °C without derating, max. 55 °C with derating 0 to 1000 m without derating, max. 3000 m with derating
Continuous Stall Torque Range	From 0.5 to 23 Nm
Degree of protection as per EN60529	IP67 (Excluding BPX055)
Connection	By rotary connector
Permanent Magnet Holding Brake	24 VDC available as option (excluding the high inertia version)
Motor Transducer	High resolution single turn and multi turn optical encoder Medium resolution single turn and multi turn optical encoder Medium resolution single turn and multi turn optical encoder 2 wires (for SPX only) Medium resolution single turn and multi turn optical encoder 2 wires SIL 2 (for SPX only)
Mounting Restriction	No mounting restrictions, IMB5 - IMV1 - IMV3 as per EN60034-7
Finishing	Black glossy polyurethane varnish

Technical Characteristics

For peak torque figures please refer to chapter 7 where the drive-motor associations are described.

BPX SPX	Low speed continuous torque	Rated speed	Rotor Inertia			Motor weight			Brake		Low speed continuous current	Dimens. Power
			without brake	with brake	high inertia version	without brake	with brake	high inertia version	Torque	Current		
	[Nm]	[rpm]	[g.m ²]	[g.m ²]	[g.m ²]	[kg]	[kg]	[kg]	[Nm]	[A]	[Arms]	[kW]
0551V5... ¹	0.5	6 000	0.006	0.008	-	1.2	1.4	-	0.8	0.4	0.7	0.31
0751V5...	1.4	6 000	0.07	0.08	0.12	2.2	2.4	2.5	2.2	0.4	2.0	0.88
0752V5...	2.3	6 000	0.13	0.14	0.18	3.2	3.4	3.5			3.4	1.45
0951V5...	2.7	6 000	0.20	0.26	0.54	3.6	4.3	4.5	6.0	0.7	3.4	1.70
0952N5...	5.0	3 000	0.37	0.43	0.71	5.2	5.9	6.1			3.3	1.57
0952V5...		6 000									6.6	3.14
1261N5...	5.2	3 000	0.55	0.69	1.49	6.0	7.5	7.7	13.0	0.8	3.7	1.63
1261V5...		6 000									7.4	3.27
1262N5...	9.8	3 000	1.07	1.21	2.01	8.5	10.0	10.2			7.0	3.08
1262V5...		6 000							14.0	6.16		
1263R5...	12.6	4 500	1.58	1.72	2.52	11.2	12.7	12.9			11.5	5.94
1552N5...	13.8	3 000	2.45	2.86	5.25	12.5	14.7	15.2	29.0	0.9	8.7	4.34
1552R5...		4 500									11.7	6.50
1554N5...		3 000									4.76	5.17

¹ SPX version not available



BPX Servomotor Ordering Codes

	BPX	075	1	V	5	Q	A	2	L	0	2
Series											
Size (055, 075, 095, 126, 155)											
Length											
Winding type											
Connection type											
• Standard right-angled M23 rotatable connectors					5						
Sensor type											
• High resolution multi-turn encoder ³						P					
• High resolution single-turn encoder ³						Q					
• Medium resolution multi-turn encoder						J					
• Medium resolution single-turn encoder ³						K					
Brake											
• Without brake							A				
• With brake							F				
• High inertia version ^{1,4}							G				
Version											
• Standard								2			
Shaft extension											
• Smooth									L		
• Keyed									C		
Type of customization											
• Standard										0	
Degree of protection (shaft extension/frame)											
• IP 65/65 ²											1
• IP 67/67											2

¹ Brake option not available

² Mandatory choice for BPX055, not available for other sizes

³ Sensor type not available for BPX055

⁴ Option not available for BPX055



SPX Servomotor Ordering Codes

	SPX	075	1	V	5	Y	A	2	L	0	2
Series											
Size (075, 095, 126, 155)											
Length											
Winding type											
Connection type											
• Standard right-angled M23 rotatable connectors	5										
Sensor type											
• High resolution multi-turn encoder 2-wires	Y										
• High resolution single-turn encoder 2-wires	Z										
• Medium resolution multi-turn encoder 2-wires	I										
• Medium resolution single-turn encoder 2-wires	L										
Brake											
• Without brake	A										
• With brake	F										
• High inertia version ¹	G										
Version											
• Standard	2										
Shaft extension											
• Smooth	L										
• Keyed	C										
Type of customization											
• Standard	0										
Degree of protection (shaft extension/frame)											
• IP 67/67	2										

¹ Brake option not available



Servomotor Outlines

bhx
bpX

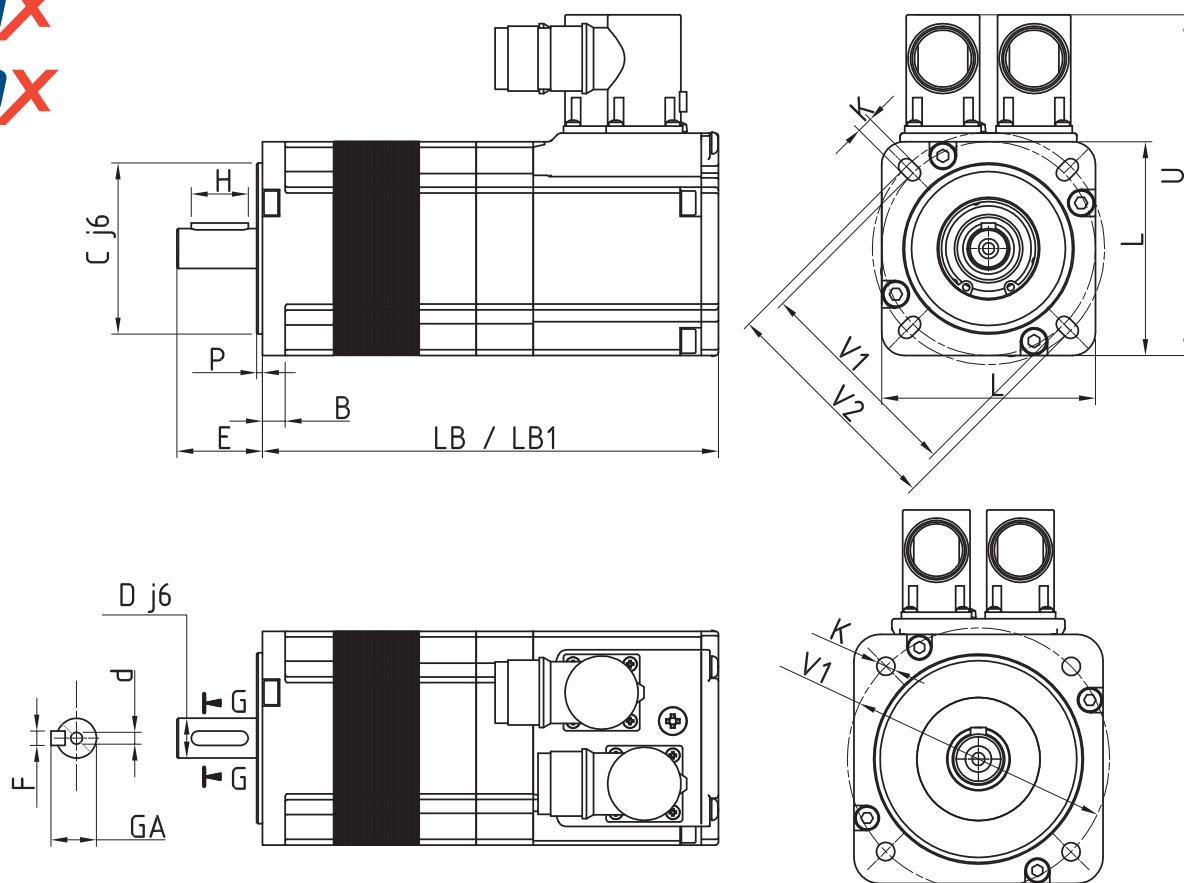

BHX BPX	L	LB ¹	LB1 ¹	C	P	B	V1	V2	K	U	D	E	H	F	GA	d
	[mm]	[mm]	[mm]	[mm]	[mm]	[mm]	[mm]	[mm]	[mm]	[mm]	[mm]	[mm]	[mm]	[mm]	[mm]	[mm]
0751...	75	140	160	60	2.5	8	75	81.5	5.5	119.5	14	30	20	5	16.0	M5x10
0752...		170	190													
0951...	95	153	183	80	3.0	10	100	-	7.0	140.5	19	40	30	6	21.5	M6x16
0952...		183	213													
1261...	126	149	194	110	3.5	11	130	-	9.0	175.0	24	50	40	8	27.0	M8x19
1262...		179	224													
1263...		209	254													
1552...	155	192	235	130	3.5	13	165	-	11.0	200.0	32	58	45	10	35.0	M12x28
1554...		242	285													

¹ LB without brake, LB1 with brake or high inertia version



BPX 055 Servomotor Outlines

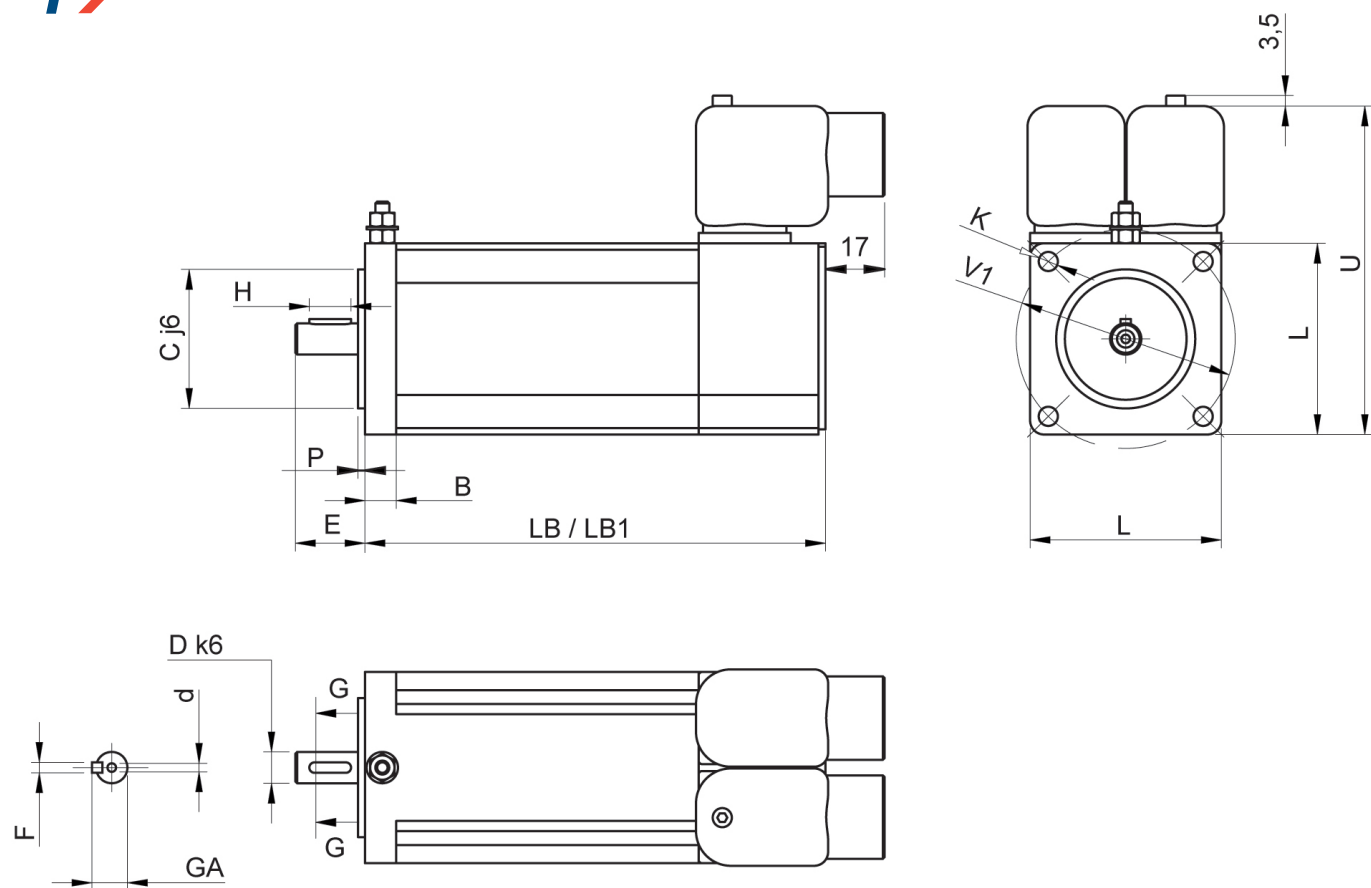

6

BPX	L	LB	LB1 ¹	C	P	B	V1	K	U	D	E	H	F	GA	d
	[mm]	[mm]	[mm]	[mm]	[mm]	[mm]	[mm]	[mm]	[mm]	[mm]	[mm]	[mm]	[mm]	[mm]	[mm]
0551	55	133	159	40	2	9	63	5.5	94.5	9	20	12	3	10.2	M3x9



Servomotor Outlines

shx
spx

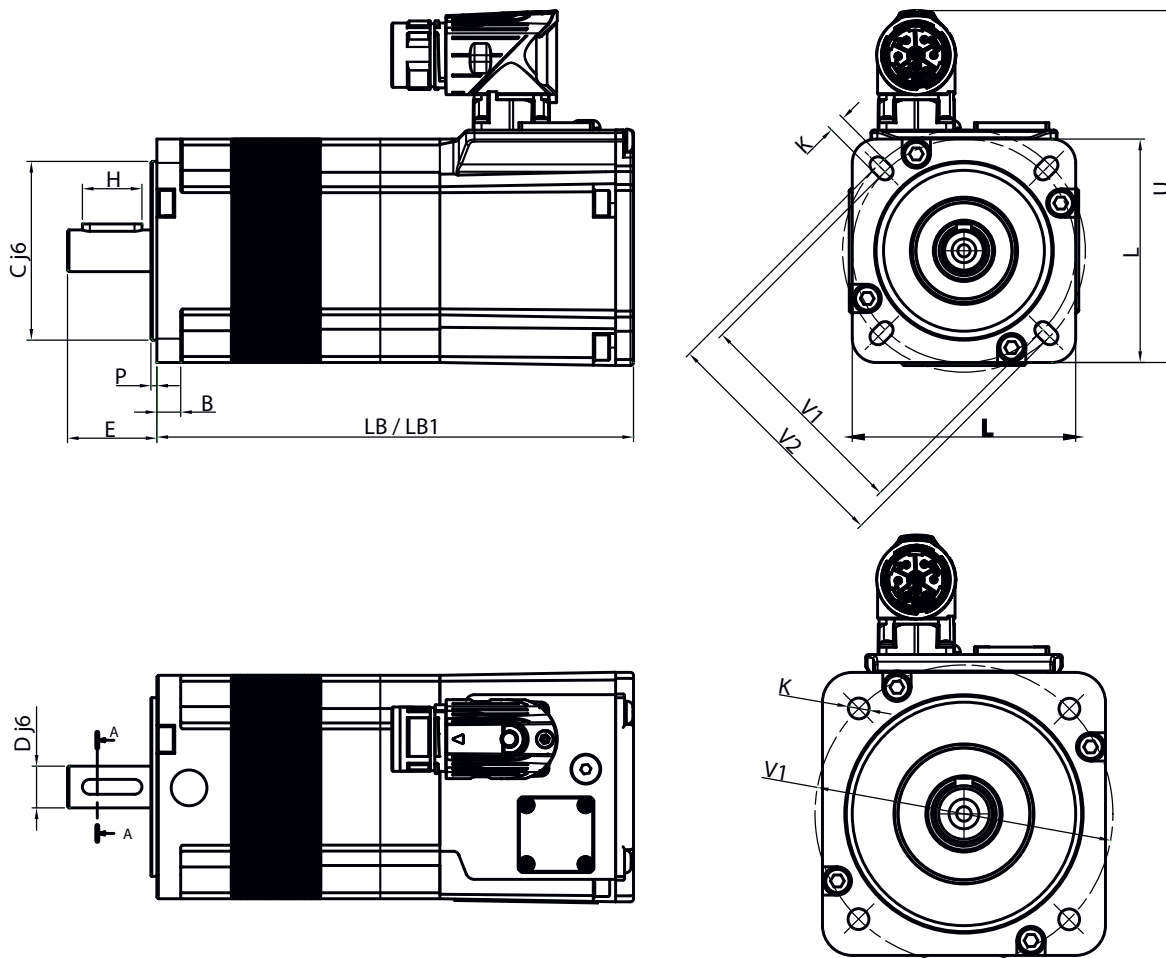

SHX SPX	L	LB ¹	LB1 ¹	C	P	B	V1	V2	K	U	D	E	H	F	GA	d
	[mm]	[mm]	[mm]	[mm]	[mm]	[mm]	[mm]	[mm]	[mm]	[mm]	[mm]	[mm]	[mm]	[mm]	[mm]	[mm]
0751...	75	140	160	60	2.5	8	75	81.5	5.5	119.5	14	30	20	5	16.0	M5x10
0752...		170	190													
0951...	95	153	183	80	3.0	10	100	-	7.0	140.5	19	40	30	6	21.5	M6x16
0952...		183	213													
1261...	126	149	194	110	3.5	11	130	-	9.0	175.0	24	50	40	8	27.0	M8x19
1262...		179	224													
1263...		209	254													
1552...	155	192	235	130	3.5	13	165	-	11.0	200.0	32	58	45	10	35.0	M12x28
1554...		242	285													

¹ LB without brake, LB1 with brake or high inertia version



BPH Servomotor General Characteristics

BPH servomotors are compact medium inertia units, designed for the feeding axes of high-end machine tools, grinding machines, robotics and special machines. They are available in 75 mm, 95 mm, 115 mm, 142 mm and 190 mm frame sizes, with a variety of options.

General Motor Features	As per EN60034-1
Environment Storage Conditions <ul style="list-style-type: none"> • Temperature Range • Relative Humidity 	-20 to +80 °C max. 80% without condensation
Environment Working Conditions <ul style="list-style-type: none"> • Temperature Range • Altitude 	0 to 40 °C without derating, max. 55 °C with derating 0 to 1000 m without derating, max. 3000 m with derating
Continuous Stall Torque Range	From 1.3 to 100 Nm
Degree of protection as per EN60529	IP65 IP67 as option
Connection	By 90° connector
Permanent Magnet Holding Brake	24 VDC available as option
Motor Transducer	High resolution single turn and multi turn optical encoder Medium resolution single turn and multi turn optical encoder
Mounting Restriction	No mounting restrictions, IMB5 - IMV1 - IMV3 as per EN60034-7
Finishing	Black



BPH Servomotor Technical Characteristics

For peak torque figures please refer to chapter 7 where the drive-motor associations are described.

BPH	Low Speed Continuous Torque	Rated Speed	Rotor Inertia		Motor Weight		Brake		Low Speed Continuous Current	Dimensioning Power
			Without Brake	With Brake	Without Brake	With Brake	Torque	Current		
	[Nm]	[rpm]	[g.m ²]	[g.m ²]	[kg]	[kg]	[Nm]	[A]	[Arms]	[kW]
0751N5...	1.3	3 000	0.08	0.12	3.5	3.85	2.5	0.5	2.2	0.41
0751V5...		6 000							3.0	0.82
0752N5...	2.3	3 000	0.12	0.16	4.3	4.65	2.5	0.5	2.7	0.72
0752V5...		6 000							3.5	1.45
0754N5...	4.0	3 000	0.21	0.25	6.0	6.35	5.0	0.7	3.5	1.26
0952N5...	4.3	3 000	0.30	0.41	6.7	7.50			3.5	1.35
0952V5...		6 000					5.9	2.70		
0953N5...	6.0	3 000	0.41	0.52	8.0	8.80	5.0	0.7	5.2	1.88
0953V5...		6 000							10.3	3.77
0955N5...	9.2	3 000	0.64	0.75	10.5	11.30	11.0	0.8	5.8	2.89
1152N5...	7.4	3 000	0.70	1.07	9.6	10.90	12.0		5.5	2.32
1152V5...		6 000						10.5	4.65	
1153K5...	10.5	2 000	0.97	1.34	11.7	13.00	12.0	0.8	5.3	2.20
1153N5...		3 000							9.2	3.30
1153V5...	13.3	6 000	1.25	1.62	13.8	15.10	12.0	0.8	12.6	6.60
1154K5...		2 000							6.2	2.79
1154N5...	13.3	3 000	1.25	1.62	13.8	15.10	12.0	0.8	10.1	4.18
1154V5...		6 000							17.6	8.36
1156N5...	18.7	3 000	1.80	2.17	17.9	19.20	22.0	1.0	12.0	5.87
1422K5...	12.0	2 000	1.59	2.54	17.2	19.40	20.0		1.0	6.0
1422N5...		3 000						10.4		3.77
1422R5...	17.0	4 250	2.19	3.14	20.1	22.30	20.0	1.0	11.5	5.34
1423K5...		2 000							9.5	3.56
1423N5...	17.0	3 000	2.19	3.14	20.1	22.30	20.0	1.0	11.7	5.34
1423R5...		4 250							16.9	7.57
1424K5...	22.0	2 000	2.79	3.74	23.0	25.20	20.0	1.0	10.4	4.61
1424N5...		3 000							15.6	6.91
1424R5...	35.0	4 250	4.29	5.24	31.7	33.90	20.0	1.0	20.8	9.79
1427N5...		3 000							24.2	11.00
1902K5...	25.0	2 000	5.14	8.25	32.1	36.20	40.0	1.5	16.6	5.24
1902N5...		3 000							19.9	7.85
1902R5...	36.0	4 250	7.10	10.20	37.3	41.40	40.0	1.5	29.2	11.13
1903K5...		2 000							19.7	7.54
1903N5...	36.0	3 000	7.10	10.20	37.3	41.40	40.0	1.5	27.8	11.31
1904K5...		2 000							20.6	9.63
1904N5...	46.0	3 000	9.04	12.10	42.4	46.50	40.0	1.5	30.3	14.45
1905H5...		1 500							20.0	8.80
1905L5...	56.0	2 500	11.00	14.10	47.6	51.70	40.0	1.5	31.4	14.66
1907K5...		2 000							27.9	15.71
1907N5...	75.0	3 000	14.90	18.00	58.0	62.10	80.0	1.5	52.3	23.56
190AK5...		2 000							44.0	20.94



BPH Servomotor Ordering Codes

	BPH	075	1	N	5	Q	A	2	L	0	1
Series											
Size (075, 095, 115, 142, 190)											
Length											
Winding type											
Fixed value					5						
Sensor type											
<ul style="list-style-type: none"> High resolution multi-turn encoder High resolution single-turn encoder Medium resolution multi-turn encoder Medium resolution single-turn encoder 						P	Q	J	K		
Brake											
<ul style="list-style-type: none"> Without brake With brake 							A	F			
Fixed value								2			
Shaft extension											
<ul style="list-style-type: none"> Smooth Keyed 									L	C	
Fixed value										0	
Degree of protection (shaft extension/frame)											
<ul style="list-style-type: none"> IP 65/65 IP 67/67 option 											1
											2

6

BPH Servomotor Outlines

See page 192 for BPH & BPG servomotor outlines.



BPG Servomotor General Characteristics

BPG servomotors are compact very high inertia units, designed for the feeding axes of high-end machine tools, grinding machines, robotics and special machines. They are available in 75 mm, 95 mm, 115 mm, 142 mm and 190 mm frame sizes, with a variety of options.

General Motor Features	As per EN60034-1
Environment Storage Conditions • Temperature Range • Relative Humidity	-20 to +80 °C max. 80% without condensation
Environment Working Conditions • Temperature Range • Altitude	0 to 40 °C without derating, max. 55 °C with derating 0 to 1000 m without derating, max. 3000 m with derating
Continuous Stall Torque Range	From 1.3 to 56 Nm
Degree of protection as per EN60529	IP65 IP67 as option
Connection	By 90° connector
Permanent Magnet Holding Brake	Not available
Motor Transducer	High resolution single turn and multi turn optical encoder Medium resolution single turn and multi turn optical encoder
Mounting Restriction	No mounting restrictions, IMB5 - IMV1 - IMV3 as per EN60034-7
Finishing	Black

BPG Servomotor Technical Characteristics

For peak torque figures please refer to chapter 7 where the drive-motor associations are described.

BPG	Low Speed Continuous Torque	Rated Speed	Rotor Inertia		Motor Weight		Brake		Low Speed Continuous Current	Dimensioning Power
			Without Brake	With Brake	Without Brake	With Brake	Torque	Current		
			[Nm]	[rpm]	[g.m ²]	[g.m ²]	[kg]	[kg]		
0751N5...	1.3	3 000	0.25		4.0				2.2	0.41
0752N5...	2.3	3 000	0.30		4.8				2.7	0.72
0952N5...	4.3	3 000	0.86		7.6				3.5	1.35
0953N5...	6.0	3 000	0.97		8.9				5.2	1.88
1152N5...	7.4	3 000	2.45		11.2				5.5	2.32
1153K5...		2 000							5.3	2.20
1153N5...	10.5	3 000	2.73		13.3				9.2	3.30
1153V5...		6 000							12.6	6.60
1422N5...	12.0	3 000	6.70		20.4				10.4	3.77
1423N5...	17.0	3 000	7.30	-	23.3	-	-	-	11.7	5.34
1424K5...		2 000							10.4	4.61
1424R5...	22.0	4 250	7.90		26.2				20.8	9.79
1427N5...	35.0	3 000	9.70		34.9				24.2	11.00
1902K5...		2 000							16.6	5.24
1902N5...	25.0	3 000	20.90		38.1				19.9	7.85
1903K5...		2 000							19.7	7.54
1903N5...	36.0	3 000	22.90		43.3				27.8	11.31
1904N5...	46.0	3 000	24.80		48.6				30.3	14.45
1905L5...	56.0	2 500	26.80		53.6				31.4	14.66



BPG Servomotor Ordering Codes

	BPG	075	1	N	5	Q	A	2	L	0	1
Series											
Size (075, 095, 115, 142, 190)											
Length											
Winding type											
Fixed value					5						
Sensor type											
<ul style="list-style-type: none"> High resolution multi-turn encoder High resolution single-turn encoder Medium resolution multi-turn encoder Medium resolution single-turn encoder 						P					
						Q					
						J					
						K					
Brake											
<ul style="list-style-type: none"> Brake not available 							A				
Fixed value								2			
Shaft extension											
<ul style="list-style-type: none"> Smooth Keyed 									L		
									C		
Fixed value										0	
Degree of protection (shaft extension/frame)											
<ul style="list-style-type: none"> IP 65/65 IP 67/67 option 											1
											2



BPH & BPG Servomotor Outlines

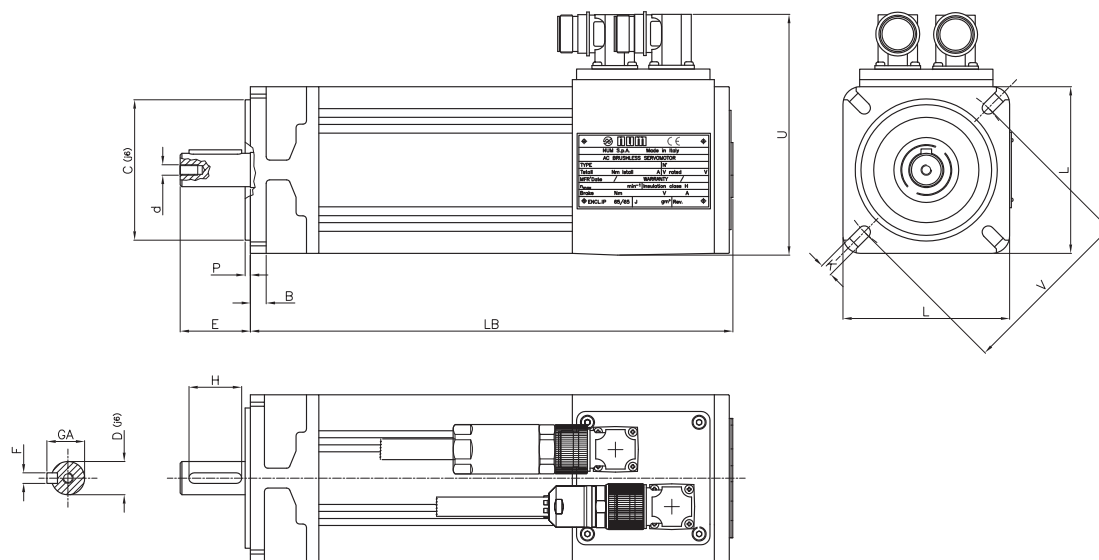

BPH BPG									BPH Shaft					BPG Shaft						
	L	LB ³	C	P	B	V	K	U	D	E	H	F	GA	d	D	E	H	F	GA	d
	[mm]	[mm]	[mm]	[mm]	[mm]	[mm]	[mm]	[mm]	[mm]	[mm]	[mm]	[mm]	[mm]	[mm]	[mm]	[mm]	[mm]	[mm]	[mm]	[mm]
0751...		221							11	23	15	4	12.5	M4x10	14	30	20	5	16	M5x12
0752...	75	250	60	2.5	8	75	6	117	14	30	20	5	16	M5x12						
0754...		308																		
0952...		275													19	40	30	6	21.5	M6x16
0953...	95	304	80	3	9	100	7	137	19	40	30	6	21.5	M6x16						
0955...		362																		
1152...		290							19	40	30	6	21.5	M6x16	24	50	40	8	27	M8x19
1153...	115	319	95	3	10	115	9	166	24	50	40	8	27	M8x19						
1154...		348																		
1156...		406																		
1422...		316																		
1423...	142	345	130	3	14	165	11	193	24	50	40	8	27	M8x19	32	58	46	10	35	M12x28
1424...		374							32	58	45	10	35	M12x28						
1427...		461																		
1902...		355																		
1903...		384																		
1904...	190	413	180	3	17	215	14	242 ¹ or 258 ²	32	58	45	10	35	M12x28	38	80	70	10	41	M12x28
1905...		442																		
1907...		500																		
190A...		605							38	80	70	10	41	M12x28						

¹ 190 2K. 2N. 3K. 4K. 5H

² 190 2R. 3N. 4N. 5L. 7K. AK

³ BPH length doesn't change with or without brake



BHL Servomotor General Characteristics

BHL servomotors are very compact high inertia units, designed for the feeding axes of large machine tools. They are available in one, 260 mm, frame size, with a variety of options.

General Motor Features	As per EN60034-1
Environment Storage Conditions <ul style="list-style-type: none"> Temperature Range Relative Humidity 	-20 to +80 °C max. 80% without condensation
Environment Working Conditions <ul style="list-style-type: none"> Temperature Range Altitude 	0 to 40 °C without derating, max. 55 °C with derating 0 to 1000 m without derating, max. 3000 m with derating
Continuous Stall Torque Range	From 85 to 160 Nm
Degree of protection as per EN60529	Housing IP65, shaft and fan IP54
Connection	Fanless version: connector Fan cooled version: terminal board
Permanent Magnet Holding Brake	24 VDC available as option
Motor Transducer	High resolution single turn and multi turn optical encoder
Mounting Restriction	No mounting restrictions, IMB5 - IMV1 - IMV3 as per EN60034-7
Finishing	Black

BHL Servomotor Technical Characteristics

For peak torque figures please refer to chapter 7 where the drive-motor associations are described.

BHL	Low speed continuous torque	Rated speed	Rotor Inertia		Motor weight		Brake		Low speed continuous current	Dimensioning Power
			without brake	with brake	without brake	with brake	Torque	Current		
			[Nm]	[rpm]	[g.m ²]	[g.m ²]	[kg]	[kg]		
2601N5xx2...	85	3 000	45.0	48.1	95	99	80	1.5	52.0	26.70
2601N1xxV... ¹	120				100	104			75.0	37.70
2602K5xx2...	120	2 000	66.2	69.3	126	130			52.0	25.13
2602K1xxV... ¹	160				131	135			69.3	33.51

¹ BHL motors with forced convection (V) require an auto-transformer for 480Vac network (code: AMOTRF001)



BHL Servomotor Ordering Codes

	BHL	260	1	N	1	Q	A	2	L	0	5
Series											
Size											
Length											
Winding type											
Power connection											
• With terminal box mandatory for forced convection version						1					
• With power connector mandatory for natural convection version						5					
Sensor type											
• High resolution multi-turn encoder						P					
• High resolution single-turn encoder						Q					
Brake											
• Without brake							A				
• With brake							F				
Cooling											
• Natural convection								2			
• With fan (ventilated)								V			
Shaft extension											
• Smooth									L		
• Keyed									C		
Fixed value										0	
Degree of protection (shaft extension/frame/fan if present)											
• IP 54/65/54											5

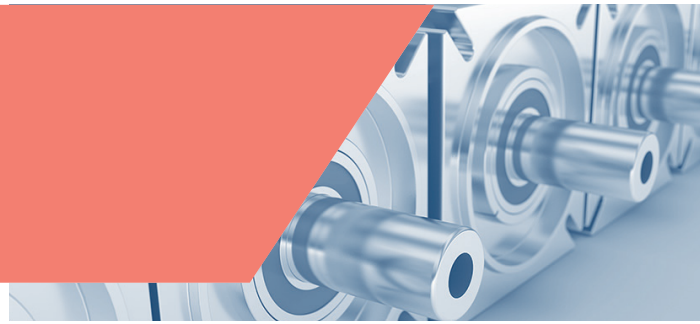

BHL Servomotor Outlines

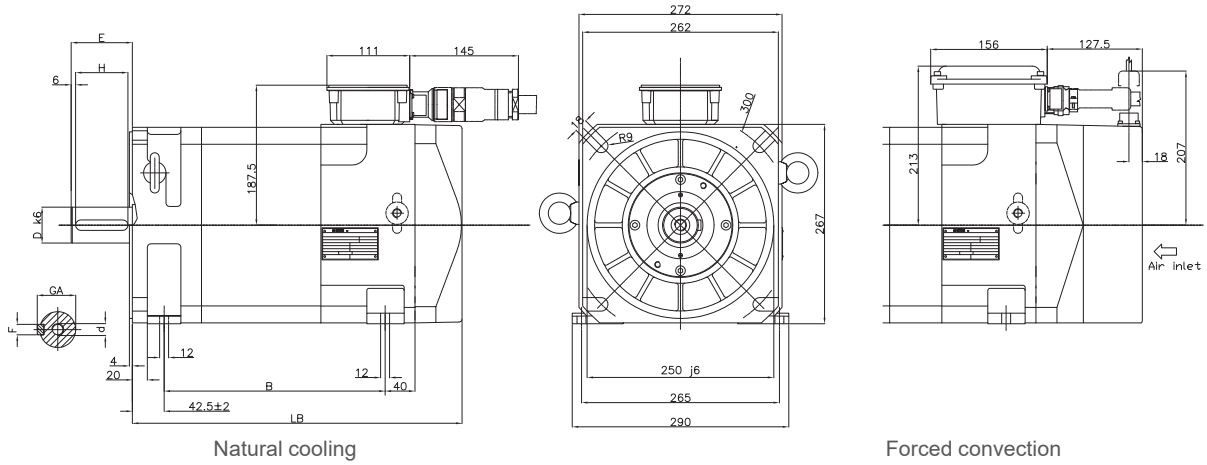

BHL	LB	B	D	E	H	F	GA	d
	[mm]	[mm]	[mm]	[mm]	[mm]	[mm]	[mm]	[mm]
2601x5xx2...	440	296 ± 2	48	82 ± 1	70	14	51.5	M16x36
2601x1xxV...	521	296 ± 2						
2602x5xx2...	510	366 ± 2						
2602x1xxV...	591							



TMX Direct Drive Torque Motors General Characteristics

TMX are very compact torque motors for direct drive applications.

TMX motors are compatible with the major competitor's solutions providing very low cogging torque and very high S1 torque density.

Three motor diameter sizes are available in different lengths and additional sizes are being developed. If the existing motor range do not cover your needs, please get in touch with NUM.

Type of construction	IM 5110 (EN 60034-7)
Cooling	Liquid cooling (EN 60034-5)
Thermal motor protection	2 x KTY84 and PTC triplet
Maximum winding temperature	130°C
Stator insulation class	H (EN 60034-1; UL 1004; CSA 100)
Maximum inlet water temperature	25°C
Installation height above sea level	< 1000 m, then derating is needed
Supply voltage	3ph AC up to 480 Vrms
Electrical connections	cable with cable gland
Feedback system	not previewed
Mechanical architecture	Stator with steel cooling jacked + rotor sleeve with surface permanent magnets
Marking	CE



TMX Direct Drive Torque Motors Technical Characteristics

For peak torque figures, please refer to chapter 7, where the drive-motor associations are described.

TMX	Low speed continuous torque ¹	Low speed continuous current ¹	Peak torque	Peak current	Maximum mechanical speed	Motor weight	
	[Nm]	[Arms]	[Nm]	[Arms]	[rpm]	Stator [kg]	Rotor [kg]
TMX140050D..	33	6.5	57	19.5	1500	6.2	1.2
TMX140070C..	50	13	81	35	1500	8	1.6
TMX210070I..	174	12.6	350	34	500	11	3.5
TMX291050H..	230	18.5	435	53	500	16.6	3.4
TMX291070I..	325	23.5	610	65	500	21	5

¹ Water cooling



TMX Direct Drive Torque Motors Ordering Codes

	TMX	140	070	C	3	A	0	0	512
Series									
Stator diameter									
• 140 mm		140							
• 210 mm		210							
• 291 mm		291							
Stator stack length									
• 50 mm			050						
• 70 mm			070						
Winding type									
• Ke within 2,01 and 3,00 V*sec/rad				C					
• Ke within 3,01 and 4,00 V*sec/rad				D					
• Ke within 7,01 and 8,00 V*sec/rad				H					
• Ke within 8,01 and 9,00 V*sec/rad				I					
Cable type									
• Cables with cable gland					3				
Cable length									
• 2 m						A			
Type of supply									
• Stator and rotor							0		
Spare numbers									0
Drawing number									
• Last 3 digit of the outline drawing number									xxx



TMX Direct Drive Torque Motors Outlines

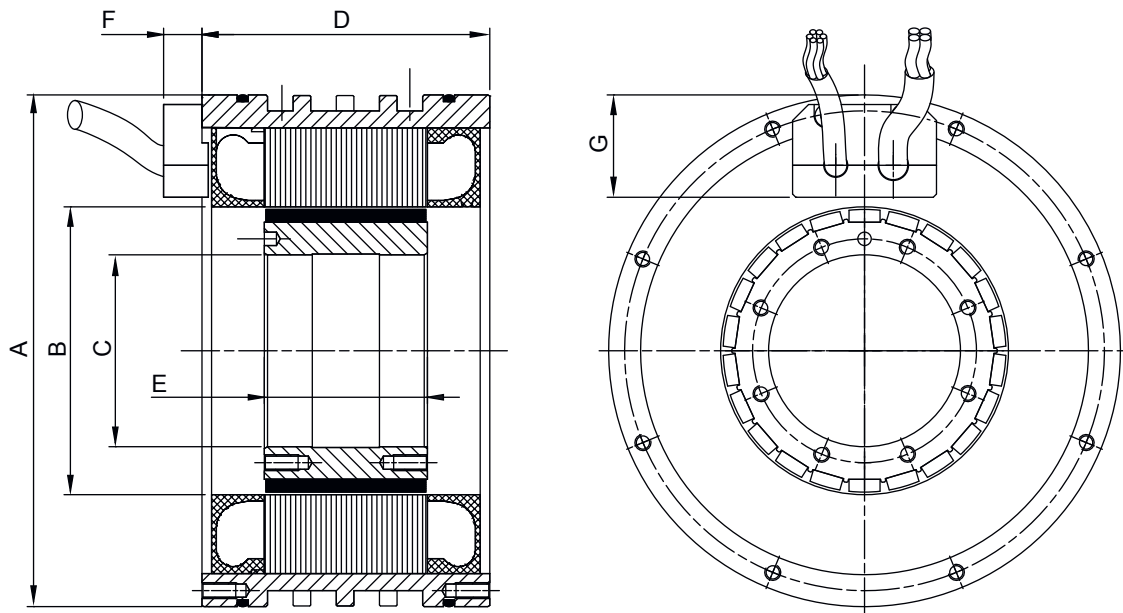

6

TMX	A	B	C	D	E	F	G
	[mm]	[mm]	[mm]	[mm]	[mm]	[mm]	[mm]
TMX140050..	160	90	60	90	51	12	32
TMX140070..	160	90	60	110	71	12	32
TMX210070..	230	170	140	110	71	12	29
TMX291050..	310	230	200	100	51	12	36
TMX291070..	310	230	200	120	71	12	36



AMS & IM Spindlemotors General Characteristics

AMS asynchronous spindle motors incorporate a high resolution encoder and are capable of fast and accurate positioning, making them ideal for C axis control as well as spindle indexing applications. The motors are compact, have a low rotor inertia, and feature a built-in axial fan.

By using the flux vector control capabilities of NUMDrive modules, AMS spindle motors ensure very smooth rotation, even at low speeds.

Special versions of AMS spindle motors (size 132 and 160) are available for applications involving very high radial loads.

General Motor Features	As per EN60034-1
Environment Storage Conditions <ul style="list-style-type: none"> • Temperature Range • Relative Humidity 	-20 to +80 °C max. 80% without condensation
Environment Working Conditions <ul style="list-style-type: none"> • Temperature Range • Altitude 	0 to 40 °C without derating, max. 55 °C with derating 0 to 1000 m without derating, max. 3000 m with derating
Rated Power	From 3.7 up to 55 kW
Degree of Protection as per EN60529	IP65 for the housing IP54 for the fan IP54 for the shaft, optionally IP65
Connection	By terminal board for the power By connector for the encoder
Motor Transducer	High resolution single turn and multi turn optical encoder
Mounting Restriction	No mounting restrictions, IMB5 - IMV1 - IMV3 as per EN60034-7
Vibration Class as per EN60034-14	R class, optionally S class
Fan Input Voltage	400 Vac ± 5% 3 phases, 50/60 Hz (AMS motors) 220 Vac ± 5% 1 phase, 50/60 Hz (IM motors)



AMS Spindlemotors Technical Characteristics

For power figures please refer to chapter 7 where the drive-motor associations are described.

AMS	Connection	Rated Continuous Power	Rated Speed	Max Speed	Rated Torque	Rated Continuous Current	Rotor Inertia	Fan (3 Phases)		Motor Weight			
		[kW]	[rpm]	[rpm]	[Nm]	[Arms]	[g.m ²]	Voltage	Current				
								[V]	[Arms]		[Kg]		
100SB1...	Y	3.7	1500	6500	24	20	9	400	0.11	37			
100MB1...	Y	5.5			35	26	14			49			
100GB1...	Y	9.0			57	39	23			71			
100SD1...	Y	3.7		12000	24	20	9			37			
100MD1...	Y	5.5			35	26	14			49			
100GD1...	Y	9.0			57	39	23			71			
132SA1...	Y	5.0	750	7000	64	26	55		0.20	105			
132SC1...	Y	10.0	1500		64	39							
132SE1...	Δ	15.0	1750		82	52							
132MA1...	Y	7.5	750		75	95	39			131			
132MC1...	Y	15.0	1500			95	52						
132ME1...	Δ	19.5	2000			100	72						
132LA1...	Y	11.0	750		10000	140	52			113	183		
132LE1...	Y	22.0	1250			168	72						
132SF1...	Y	5.0	750			55	64					26	105
132SG1...	Y	10.0	1500				64			39			
132SH1...	Δ	15.0	1750				82			52			
132MF1...	Y	7.5	750			75	95			39		131	
132MG1...	Y	15.0	1500	95	52								
132MH1...	Δ	19.5	2000	93	72								
132LF1...	Y	11.0	750	9000	140	52	113	183					
132LI1...	Y	12.5	680		175	39							
132LH1...	Y	22.0	1250		168	72							
160MA1...	Y	18.0	650	8500	264	52	250	0.30	215				
	Δ		1300		132								
160MB1...	Y	26.0	1200		208	72				250	0.30	215	
	Δ		2400										104
160MC1...	Δ	36.0	1700		202	100				370			290
160LA1...	Y	18.0	500		344	52							
	Δ		1000	172									
160LB1...	Y	26.0	950	260	72	370	290						
	Δ		1900					130					
160LC1...	Δ	36.0	1050	328	100								



IM Spindlemotors Technical Characteristics

For power figures please refer to chapter 7 where the drive-motor associations are described.

IM	Connec- tion Type	Rated Conti- nuous Power	Rated Speed	Max Speed	Rated Torque	Rated Conti- nuous Current	Rotor Inertia	Fan (1 Phase)		Motor Weight	
		[kW]	[rpm]	[rpm]	[Nm]	[Arms]		[g.m ²]	Voltage		Current
		[V]	[Arms]	[Kg]							
18MK14...	YY	55	1050	7500	500	145	570	230	0.8	415	

AMS Spindle Motor Ordering Codes

	AMS	100	S	B	1	Q	22	L	R	0
Series										
Size (100, 132, 160)										
Length										
Winding type										
Fixed value					1					
Sensor type										
<ul style="list-style-type: none"> High resolution multi-turn encoder High resolution single-turn encoder 						P				
						Q				
Fixed value							22			
Shaft extension										
<ul style="list-style-type: none"> Smooth Keyed 								L		
								C		
Vibration class										
<ul style="list-style-type: none"> Class R Class S 									R	
									S	
Degree of protection (shaft extension/frame/fan) and radial load										
<ul style="list-style-type: none"> IP 54/65/54 with standard permissible radial load IP 65/65/54 with standard permissible radial load IP 54/65/54 with high permissible radial load (just for size 132 and 160) IP 65/65/54 with high permissible radial load (just for size 132 and 160) 										0
										1
										2
										3



IM Spindle Motor Ordering Codes

	IM	18	M	K14	C	Q	22	L	R	0
Series										
Size										
Length										
Winding type										
Fixed value					C					
Sensor type						P				
• High resolution multi-turn encoder						Q				
• High resolution single-turn encoder										
Fixed value							22			
Shaft extension								L		
• Smooth								C		
• Keyed										
Vibration class									R	
• Class R									S	
• Class S										
Degree of protection (shaft extension)										0
• IP 54										1
• IP 65										



AMS Spindle Motor Outlines

	Shaft							
	LB	B	D	E	W	F	GA	d
	[mm]	[mm]	[mm]	[mm]	[mm]	[mm]	[mm]	[mm]
100 S	388	179 ± 1.5	32	60	50	10	35	M12x30
100 M	442	233 ± 1.5						
100 G	535	326 ± 1.5	38	80	70	10	41	
132 S	521	296 ± 2	42	110	90	12	45	M16x36
132 M	591	366 ± 2						
132 L	721	496 ± 2	48	110	90	14	51.5	

AMS 100 Motor

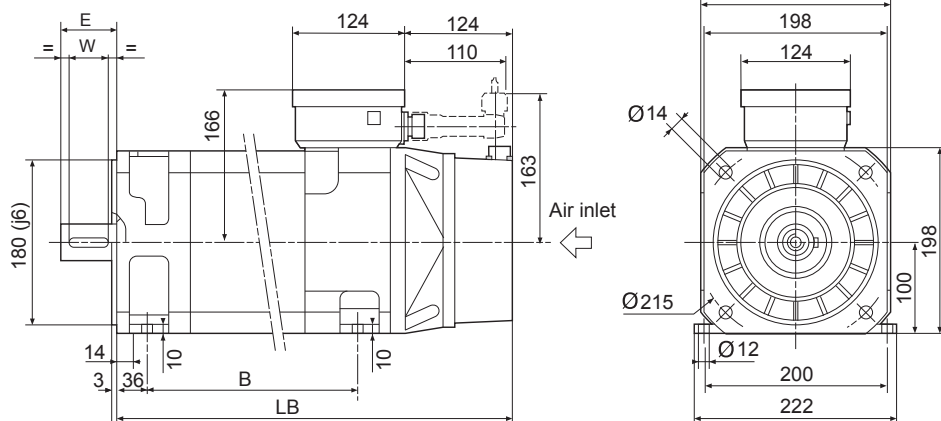
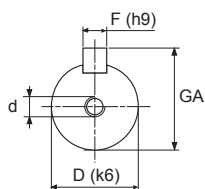

AMS 132 Motor

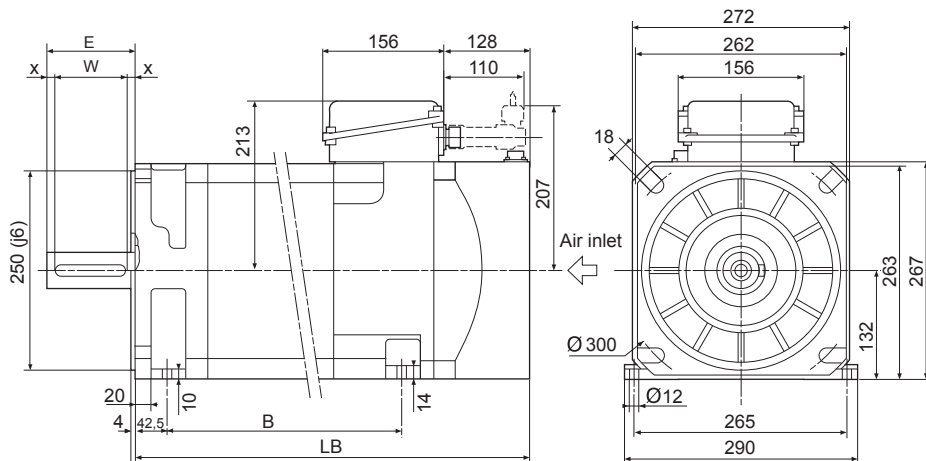

All dimensions in mm



AMS Spindle Motor Outlines

AMS 160 Motor

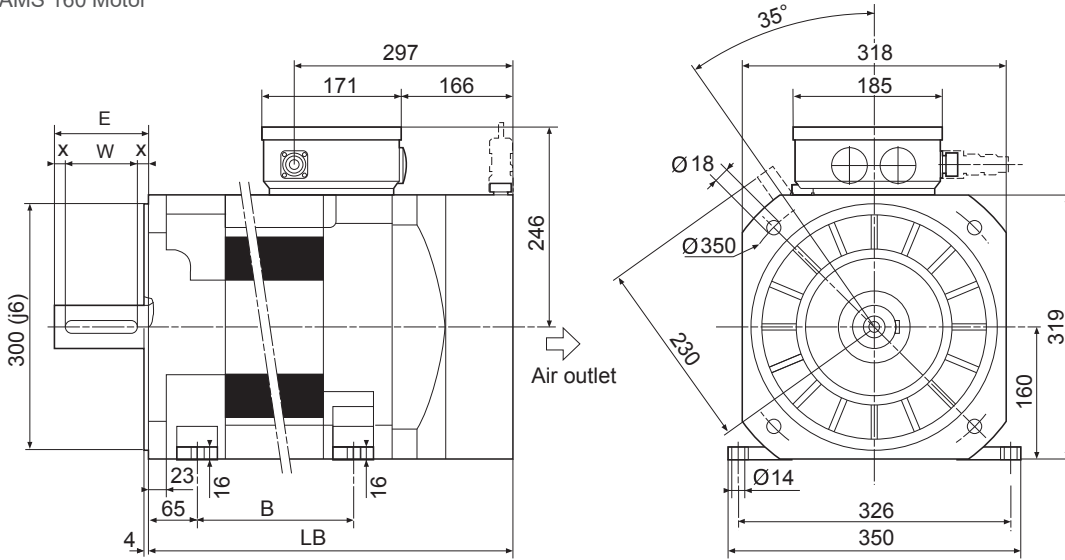

	Shaft							
	LB	B	D	E	W	F	GA	d
	[mm]	[mm]	[mm]	[mm]	[mm]	[mm]	[mm]	[mm]
160 M	682	385 ± 2	55	110	90	16	59	M20x42
160 L	827	530 ± 2						

IM Spindle Motor Outlines

IM 18MK14 Motor

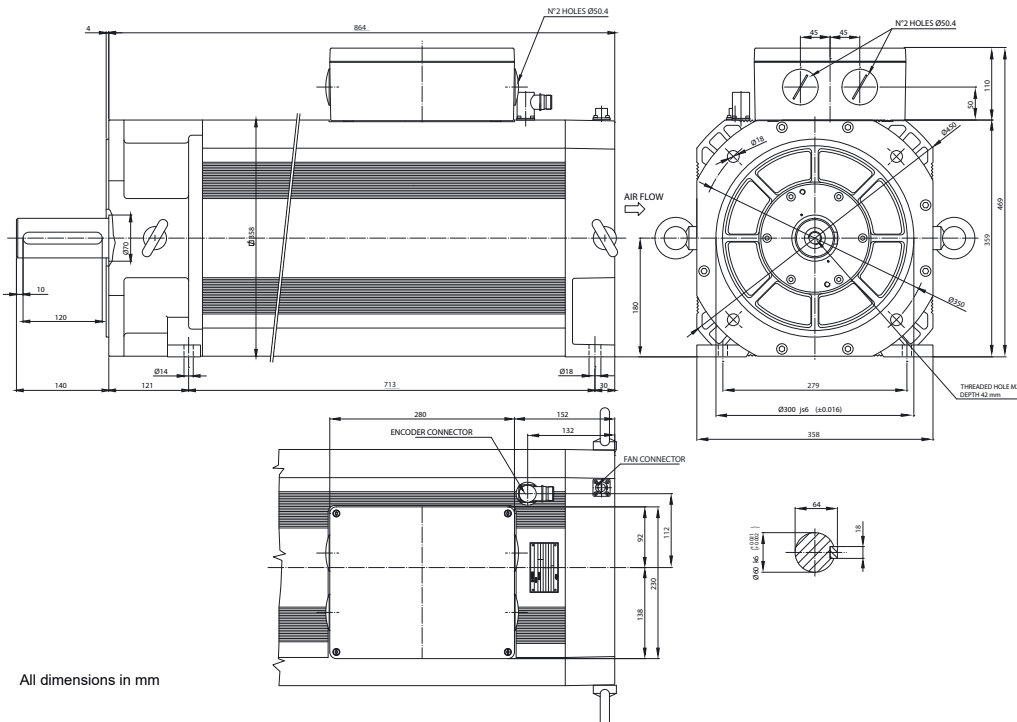

All dimensions in mm



Encoder Characteristics

All NUM motors are equipped with an encoder to provide feedback on the angular position of the rotor for phase switching. The position information is also used to close the controller's position and speed control loops.

Users can choose the type of encoder to suit their application needs, subject to the type of motor and functional safety requirements, as shown in the table below:

Sin/Cos Encoders	Technical Characteristics			
	Encoder P	Encoder Q	Encoder J	Encoder K
Sensor Type	High Resolution Multi-Turn	High Resolution Single-Turn	Medium Resolution Multi-Turn	Medium Resolution Single-Turn
Precision	< ±45 arcseconds		< ±80 arcseconds	
Operating Temperature Range	-40°C / +125°C			
Supply Voltage	7V - 12V			
Resolution per Turn	1024	1024	128	128
Turns	4096	1	4096	1
Electrical Interface	1Vpp SinCos + Hiperface			

Encoders for Single Cable Motor (SHX/SPX)	Technical Characteristics			
	Encoder Y	Encoder Z	Encoder I	Encoder L
Sensor Type	High Resolution Multi-Turn	High Resolution Single-Turn	Medium Resolution Multi-Turn	Medium Resolution Single-Turn
Precision	< ±25 arcseconds		< ±60 arcseconds	
Operating Temperature Range	-20°C / +115°C			
Supply Voltage	7V - 12V			
Measurement Step per Revolution	16777216 (24 bits)		1048576 (20 bits)	
Turns	4096	1	4096	1
Electrical Interface	Fast serial 2-wire protocol			
Functional Safety	no			
Other Info	Motor thermal probe information integrated in the encoder protocol (no need of cabling)			

The implementation of safety functions when using Flexium⁺/NUMDrive X systems does not require the usage of SIL encoders. See NUM-SAMX manual for details.



NUM Custom Motors

As well as the standard motors described on preceding pages, NUM designs and manufactures special motors and built-in (Motorspindle) motors to suit customers' specific needs.

For information about special or built-in motors, please contact your local NUM sales office.



Motorspindle®: stator elements, synchronous and asynchronous technology, for integration in electro spindles.



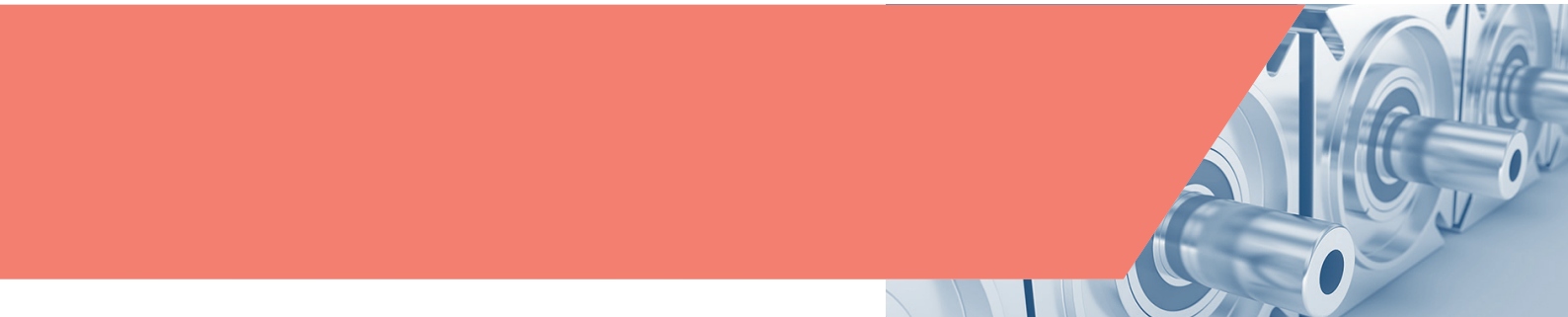

Motor/Drive Associations

Servomotors

Association of BHX & SHX Motors with NUMDrive X



Association of BHX & SHX Motors with NUMDrive X (Switching Frequency 5 kHz)

BHX SHX	MDLUX....		007B	007A	014B	014A	021B	021A	034A	050B	050A	075B	075A	100A	150A	200A	400A
	Rated speed	Low speed contin. torque	Peak torque	Peak torque	Peak torque	Peak torque	Peak torque	Peak torque	Peak torque	Peak torque	Peak torque	Peak torque	Peak torque	Peak torque	Peak torque	Peak torque	Peak torque
	[rpm]	[Nm]	[Nm]	[Nm]	[Nm]	[Nm]	[Nm]	[Nm]	[Nm]	[Nm]	[Nm]	[Nm]	[Nm]	[Nm]	[Nm]	[Nm]	[Nm]
0751V5...	6 000	1.2	3.5	3.5	4.3	4.3	4.3										
0752V5...	6 000	2.1	3.4	3.4	6.6	6.6	7.8	7.8		7.8							
0951V5...	6 000	2.4	4	4	6.4	6.4	7.5	7.5		7.5							
0952N5...	3 000	4.3	7.7	7.7	13.2	13.2	14.5	14.5		14.5							
0952V5...	6 000				7.8	7.8	10.5	10.5	14.5	14.5		14.5					
1261N5...	3 000	4.5	7	7	11.5	11.5	13	13		13							
1261V5...	6 000				7	7	9.5	9.5	12.4	13							
1262N5...	3 000	8.4			13.8	13.8	20	20	27	27		27					
1262V5...	6 000								10.5	16	22	22	27	27			
1263R5...	4 500	11						16.5	25	34	34	37					
1552N5...	3 000	12			16	16	23	23	33	39	39	39					
1552R5...	4 500								17	26.5	35	35	39				
1554N5...	3 000		20						24	38	53	53	69	69			

7

Association of BHX & SHX Motors with NUMDrive X (Switching Frequency 10 kHz)

BHX SHX	MDLUX....		007B	007A	014B	014A	021B	021A	034A	050B	050A	075B	075A	100A	150A	200A	400A
	Rated speed	Low speed contin. torque	Peak torque	Peak torque	Peak torque	Peak torque	Peak torque	Peak torque	Peak torque	Peak torque	Peak torque	Peak torque	Peak torque	Peak torque	Peak torque	Peak torque	Peak torque
	[rpm]	[Nm]	[Nm]	[Nm]	[Nm]	[Nm]	[Nm]	[Nm]	[Nm]	[Nm]	[Nm]	[Nm]	[Nm]	[Nm]	[Nm]	[Nm]	[Nm]
0751V5...	6 000	1.2	3.5	3.5	4.3	4.3	4.3										
0752V5...	6 000	2.1	3.4	3.4	6.6	6.6	7.8	7.8		7.8							
0951V5...	6 000	2.4	4	4	6.4	6.4	7.5	7.5		7.5							
0952N5...	3 000	4.3	7.7	7.7	13.2	13.2	14.5	14.5		14.5							
0952V5...	6 000				7.8	7.8	10.5	10.5	14.5	14.5		14.5					
1261N5...	3 000	4.5	7	7	11.5	11.5	13	13		13							
1261V5...	6 000								9.5	12.4	13	13	13				
1262N5...	3 000	8.4			13.8	13.8	20	20	27	27							
1262V5...	6 000									22	22	27	27				
1263R5...	4 500	11							34	34	37						
1552N5...	3 000	12						23	33	39	39	39					
1552R5...	4 500									35	35	39	39				
1554N5...	3 000		20								53	53	69	69			

In case the motor is associated to a bi-axes drive, the motor's low speed cont. torque depends on which motor type is connected at the same power unit. Refer to NUMDrive X manual M00030EN chapter 8.6 for details.

Motor/Drive Associations

Servomotors

Association of BPX & SPX Motors with NUMDrive X



Association of BPX & SPX Motors with NUMDrive X (Switching Frequency 5 kHz)

BPX SPX	MDLUX....		007B	007A	014B	014A	021B	021A	034A	050B	050A	075B	075A	100A	150A	200A	400A
	Rated speed	Low speed contin. torque	Peak torque	Peak torque	Peak torque	Peak torque	Peak torque	Peak torque	Peak torque	Peak torque	Peak torque	Peak torque	Peak torque	Peak torque	Peak torque	Peak torque	Peak torque
	[rpm]	[Nm]	[Nm]	[Nm]	[Nm]	[Nm]	[Nm]	[Nm]	[Nm]	[Nm]	[Nm]	[Nm]	[Nm]	[Nm]	[Nm]	[Nm]	[Nm]
0551V5...	6 000	0.5	1.5	1.5													
0751V5...	6 000	1.4	3.5	3.5	4.3	4.3	4.3										
0752V5...	6 000	2.3	3.4	3.4	6.6	6.6	7.8	7.8		7.8							
0951V5...	6 000	2.7	4	4	6.4	6.4	7.5	7.5		7.5							
0952N5...	3 000	5	7.7	7.7	13.2	13.2	14.5	14.5		14.5							
0952V5...	6 000				7.8	7.8	10.5	10.5	14.5	14.5		14.5					
1261N5...	3 000	5.2	7	7	11.5	11.5	13	13		13							
1261V5...	6 000				7	7	9.5	9.5	12.4	13		13					
1262N5...	3 000	9.8			13.8	13.8	20	20	27	27		27					
1262V5...	6 000									22	22	27	27				
1263R5...	4 500	12.6						16.5	25	34	34	37					
1552N5...	3 000	13.8				16	23	23	33	39	39	39					
1552R5...	4 500								17	26.5	35	35	39				
1554N5...	3 000	23								53	53	69	69				

Association of BPX & SPX Motors with NUMDrive X (Switching Frequency 10 kHz)

BPX SPX	MDLUX....		007B	007A	014B	014A	021B	021A	034A	050B	050A	075B	075A	100A	150A	200A	400A
	Rated speed	Low speed contin. torque	Peak torque	Peak torque	Peak torque	Peak torque	Peak torque	Peak torque	Peak torque	Peak torque	Peak torque	Peak torque	Peak torque	Peak torque	Peak torque	Peak torque	Peak torque
	[rpm]	[Nm]	[Nm]	[Nm]	[Nm]	[Nm]	[Nm]	[Nm]	[Nm]	[Nm]	[Nm]	[Nm]	[Nm]	[Nm]	[Nm]	[Nm]	[Nm]
0551V5...	6 000	0.5	1.5	1.5													
0751V5...	6 000	1.4	3.5	3.5	4.3	4.3	4.3										
0752V5...	6 000	2.3	3.4	3.4	6.6	6.6	7.8	7.8		7.8							
0951V5...	6 000	2.7	4	4	6.4	6.4	7.5	7.5		7.5							
0952N5...	3 000	5	7.7	7.7	13.2	13.2	14.5	14.5		14.5							
0952V5...	6 000							10.5	14.5	14.5		14.5					
1261N5...	3 000	5.2	7	7	11.5	11.5	13	13		13							
1261V5...	6 000							9.5	12.4	13	13	13					
1262N5...	3 000	9.8						20	27	27		27					
1262V5...	6 000									22	22	27	27				
1263R5...	4 500	12.6								34	34	37					
1552N5...	3 000	13.8								39	39	39					
1552R5...	4 500									35	35	39	39				
1554N5...	3 000	23								53	53	69	69				

In case the motor is associated to a bi-axes drive, the motor's low speed contin. torque depends on which motor type is connected at the same power unit. Refer to NUMDrive X manual M00030EN chapter 8.6 for details.

Motor/Drive Associations

Servomotors

Association of BPH Motors with NUMDrive X

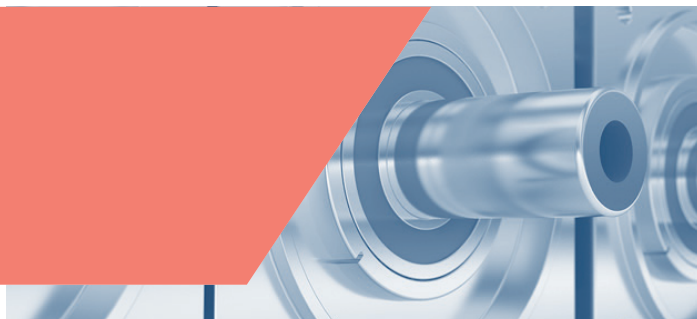

Association of BPH Motors with NUMDrive X (Switching Frequency 5 kHz)

BPH	MDLUX...		007B	007A	014B	014A	021B	021A	034A	050B	050A	075B	075A	100A	150A	200A	400A	
	Rated speed	Low speed contin. torque	Peak torque	Peak torque	Peak torque	Peak torque	Peak torque	Peak torque	Peak torque	Peak torque	Peak torque	Peak torque	Peak torque	Peak torque	Peak torque	Peak torque	Peak torque	
	[rpm]	[Nm]	[Nm]	[Nm]	[Nm]	[Nm]	[Nm]	[Nm]	[Nm]	[Nm]	[Nm]	[Nm]	[Nm]	[Nm]	[Nm]	[Nm]	[Nm]	
0751N5...	3 000	1.3			4.8	4.8	4.8											
0751V5...	6 000				3.9	3.9	3.9			3.9								
0752N5...	3 000	2.3			7.5	7.5	7.5											
0752V5...	6 000				5.9	5.9	5.9			5.9								
0754N5...	3 000	4			11	11	11											
0952N5...	3 000	4.3			11	11	11											
0952V5...	6 000				7.2	7.2	10	10			10		10					
0953N5...	3 000	6			11.2	11.2	16	16										
0953V5...	6 000									14	14	14	14					
0955N5...	3 000	9.2			15.7	15.7	22	22										
1152N5...	3 000	7.4			11.9	11.9	16	16										
1152V5...	6 000									14	14	14	14					
1153K5...	2 000	10.5			17.2	17.2	24	24										
1153N5...	3 000									22	22	22	22					
1153V5...	6 000									18	18	18	18					
1154K5...	2 000	13.3			19.8	19.8	27	27										
1154N5...	3 000									27	27	27	27					
1154V5...	6 000										23	23	23					
1156N5...	3 000	18.7								33	33	33	33					
1422K5...	2 000	12			19.2	19.2	22	22										
1422N5...	3 000									20	27	27	31					
1422R5...	4 250									19	19	19	19					
1423K5...	2 000	17								33	33	33	33					
1423N5...	3 000									28	28	28	28					
1423R5...	4 250										28	28	28					
1424K5...	2 000	22								41	41	41	41					
1424N5...	3 000										41	41	41					
1424R5...	4 250												45	45				
1427N5...	3 000	35										71	71					
1902K5...	2 000	25									40	40	40					
1902N5...	3 000										35	35	35	35				
1902R5...	4 250												36	36	36			
1903K5...	2 000	36									52	52	52	52				
1903N5...	3 000												54	54	54			
1904K5...	2 000	46										90	90					
1904N5...	3 000												69	69	69			
1905H5...	1 500	56									82	82	82	82				
1905L5...	2 500												79	79	79			
1907K5...	2 000	75										120	120	120				
1907N5...	3 000																125	125
190AK5...	2 000	100														145	145	

In case the motor is associated to a bi-axes drive, the motor's low speed cont. torque depends on which motor type is connected at the same power unit. Refer to NUMDrive X manual M00030EN chapter 8.6 for details.

Motor/Drive Associations

Servomotors

Association of BPH Motors with NUMDrive X



Association of BPH Motors with NUMDrive X (Switching Frequency 10 kHz)

BPH	MDLUX...		007B	007A	014B	014A	021B	021A	034A	050B	050A	075B	075A	100A	150A	200A	400A	
	Rated speed	Low speed contin. torque	Peak torque	Peak torque	Peak torque	Peak torque	Peak torque	Peak torque	Peak torque	Peak torque	Peak torque	Peak torque	Peak torque	Peak torque	Peak torque	Peak torque	Peak torque	
	[rpm]	[Nm]	[Nm]	[Nm]	[Nm]	[Nm]	[Nm]	[Nm]	[Nm]	[Nm]	[Nm]	[Nm]	[Nm]	[Nm]	[Nm]	[Nm]	[Nm]	
0751N5...	3 000	1.3			4.8	4.8	4.8											
0751V5...	6 000				3.9	3.9	3.9			3.9								
0752N5...	3 000	2.3			7.5	7.5	7.5			7.5								
0752V5...	6 000				5.9	5.9	5.9			5.9								
0754N5...	3 000	4			11	11	11			11								
0952N5...	3 000	4.3			11	11	11			11								
0952V5...	6 000				7.2	7.2	10	10		10		10						
0953N5...	3 000	6			11.2	11.2	16	16		16		16						
0953V5...	6 000									14	14	14						
0955N5...	3 000	9.2			15.7	15.7	22	22		22		22						
1152N5...	3 000	7.4			11.9	11.9	16	16		16		16						
1152V5...	6 000									14	14	14						
1153K5...	2 000	10.5			17.2	17.2	24	24		24		24						
1153N5...	3 000									22	22	22						
1153V5...	6 000									18	18	18						
1154K5...	2 000	13.3						27		27		27						
1154N5...	3 000									27	27	27						
1154V5...	6 000									23	23	23						
1156N5...	3 000	18.7								33	33	33						
1422K5...	2 000	12			19.2	19.2	22	22		22		22						
1422N5...	3 000									27	27	31						
1422R5...	4 250									19	19	19						
1423K5...	2 000	17								33	33	33						
1423N5...	3 000									28	28	28						
1423R5...	4 250									28	28	28						
1424K5...	2 000	22								41	41	41						
1424N5...	3 000									41	41	41						
1424R5...	4 250											45	45					
1427N5...	3 000	35										71		71				
1902K5...	2 000	25								40	40	40						
1902N5...	3 000											35	35					
1902R5...	4 250														36			
1903K5...	2 000	36										52	52					
1903N5...	3 000												54		54			
1904K5...	2 000	46										90	90					
1904N5...	3 000														69			
1905H5...	1 500	56										82	82					
1905L5...	2 500														79			
1907K5...	2 000	75										120		120				
1907N5...	3 000																125	
190AK5...	2 000		100															145

In case the motor is associated to a bi-axes drive, the motor's low speed contin. torque depends on which motor type is connected at the same power unit. Refer to NUMDrive X manual M00030EN chapter 8.6 for details.

Motor/Drive Associations

Servomotors

Association of BPG Motors with NUMDrive X



Association of BPG Motors with NUMDrive X (Switching Frequency 5 kHz)

BPG	MDLUX...		007B	007A	014B	014A	021B	021A	034A	050B	050A	075B	075A	100A	150A	200A	400A
	Rated speed	Low speed contin. torque	Peak torque	Peak torque	Peak torque	Peak torque	Peak torque	Peak torque	Peak torque	Peak torque	Peak torque	Peak torque	Peak torque	Peak torque	Peak torque	Peak torque	Peak torque
	[rpm]	[Nm]	[Nm]	[Nm]	[Nm]	[Nm]	[Nm]	[Nm]	[Nm]	[Nm]	[Nm]	[Nm]	[Nm]	[Nm]	[Nm]	[Nm]	[Nm]
0751N5...	3 000	1.3			4.8	4.8	4.8										
0752N5...	3 000	2.3			7.5	7.5	7.5			7.5							
0952N5...	3 000	4.3			11	11	11			11							
0953N5...	3 000	6			11.2	11.2	16	16		16		16					
1152N5...	3 000	7.4			11.9	11.9	16	16		16		16					
1153K5...	2 000				17.2	17.2	24	24		24		24					
1153N5...	3 000	10.5							22	22	22	22					
1153V5...	6 000								18	18	18	18					
1422N5...	3 000	12							20	31	31	31					
1423N5...	3 000	17							28	28	28	28					
1424K5...	2 000								41	41	41	41					
1424R5...	4 250	22										45	45				
1427N5...	3 000	35										71	71				
1902K5...	2 000									40	40	40					
1902N5...	3 000	25								35	35	35	35				
1903K5...	2 000									52	52	52	52				
1903N5...	3 000	36										54	54	54			
1904N5...	3 000	46										69	69	69			
1905L5...	2 500	56										79	79	79			

In case the motor is associated to a bi-axes drive, the motor's low speed cont. torque depends on which motor type is connected at the same power unit. Refer to NUMDrive X manual M00030EN chapter 8.6 for details.

Motor/Drive Associations

Servomotors

Association of BPG Motors with NUMDrive X



Association of BPG Motors with NUMDrive X (Switching Frequency 10 kHz)

BPG	MDLUX...		007B	007A	014B	014A	021B	021A	034A	050B	050A	075B	075A	100A	150A	200A	400A
	Rated speed	Low speed contin. torque	Peak torque	Peak torque	Peak torque	Peak torque	Peak torque	Peak torque	Peak torque	Peak torque	Peak torque	Peak torque	Peak torque	Peak torque	Peak torque	Peak torque	Peak torque
	[rpm]	[Nm]	[Nm]	[Nm]	[Nm]	[Nm]	[Nm]	[Nm]	[Nm]	[Nm]	[Nm]	[Nm]	[Nm]	[Nm]	[Nm]	[Nm]	[Nm]
0751N5...	3 000	1.3			4.8	4.8	4.8										
0752N5...	3 000	2.3			7.5	7.5	7.5			7.5							
0952N5...	3 000	4.3			11	11	11			11							
0953N5...	3 000	6			11.2	11.2	16	16		16		16					
1152N5...	3 000	7.4			11.9	11.9	16	16		16		16					
1153K5...	2 000				17.2	17.2	24	24		24		24					
1153N5...	3 000	10.5								22	22	22					
1153V5...	6 000									18	18	18					
1422N5...	3 000	12								27	27	31					
1423N5...	3 000	17								28	28	28					
1424K5...	2 000									41	41	41					
1424R5...	4 250	22										45	45				
1427N5...	3 000	35										71		71			
1902K5...	2 000									40	40	40					
1902N5...	3 000	25										35	35				
1903K5...	2 000											52	52				
1903N5...	3 000	36										54		54			
1904N5...	3 000	46												69			
1905L5...	2 500	56												79			

In case the motor is associated to a bi-axes drive, the motor's low speed cont. torque depends on which motor type is connected at the same power unit. Refer to NUMDrive X manual M00030EN chapter 8.6 for details.

Motor/Drive Associations

Servomotors

Association of BHL Motors with NUMDrive X



Association of BHL Motors with NUMDrive X (Switching Frequency 5 kHz)

		MDLUX...	007B	007A	014B	014A	021B	021A	034A	050B	050A	075B	075A	100A	150A	200A	400A	
BHL	Rated speed	Low speed contin. torque	Peak torque	Peak torque	Peak torque	Peak torque	Peak torque	Peak torque	Peak torque	Peak torque	Peak torque	Peak torque	Peak torque	Peak torque	Peak torque	Peak torque	Peak torque	
	[rpm]	[Nm]	[Nm]	[Nm]	[Nm]	[Nm]	[Nm]	[Nm]	[Nm]	[Nm]	[Nm]	[Nm]	[Nm]	[Nm]	[Nm]	[Nm]	[Nm]	
2601N5xx2...	3000	85														165	210	
2601N1xxV...		120																210
2602K5xx2...	2000	120														230	290	
2602K1xxV...		160																290

Association of BHL Motors with NUMDrive X (Switching Frequency 10 kHz)

		MDLUX...	007B	007A	014B	014A	021B	021A	034A	050B	050A	075B	075A	100A	150A	200A	400A		
BHL	Rated speed	Low speed contin. torque	Peak torque	Peak torque	Peak torque	Peak torque	Peak torque	Peak torque	Peak torque	Peak torque	Peak torque	Peak torque	Peak torque	Peak torque	Peak torque	Peak torque	Peak torque		
	[rpm]	[Nm]	[Nm]	[Nm]	[Nm]	[Nm]	[Nm]	[Nm]	[Nm]	[Nm]	[Nm]	[Nm]	[Nm]	[Nm]	[Nm]	[Nm]	[Nm]		
2601N5xx2...	3000	85															210		
2601N1xxV...		112																210	
2602K5xx2...	2000	120																290	
2602K1xxV...		160																	290

7

V = Ventilated version

Motor/Drive Associations

Servomotors

Association of TMX Motors with NUMDrive X



Association of TMX Motors with NUMDrive X (Switching Frequency 5 kHz)

TMX	MDLUX....		007B	007A	014B	014A	021B	021A	034A	050B	050A	075B	075A	100A	150A	200A	400A
	Rated speed	Low speed contin. torque	Peak torque	Peak torque	Peak torque	Peak torque	Peak torque	Peak torque	Peak torque	Peak torque	Peak torque	Peak torque	Peak torque	Peak torque	Peak torque	Peak torque	Peak torque
	[rpm]	[Nm]	[Nm]	[Nm]	[Nm]	[Nm]	[Nm]	[Nm]	[Nm]	[Nm]	[Nm]	[Nm]	[Nm]	[Nm]	[Nm]	[Nm]	[Nm]
TMX140050D.. Water cooled	1500	33			43	43	51	51	57	57							
TMX140070C.. Water cooled	1500	50							70	81	81	81					
TMX210070I.. Water cooled	500	174							285	350	350	350					
TMX291050H.. Water cooled	500	230								360	360	435	435				
TMX291070I.. Water cooled	500	325								442	442	560	560	610			

Association of TMX Motors with NUMDrive X (Switching Frequency 10 kHz)

TMX	MDLUX....		007B	007A	014B	014A	021B	021A	034A	050B	050A	075B	075A	100A	150A	200A	400A
	Rated speed	Low speed contin. torque	Peak torque	Peak torque	Peak torque	Peak torque	Peak torque	Peak torque	Peak torque	Peak torque	Peak torque	Peak torque	Peak torque	Peak torque	Peak torque	Peak torque	Peak torque
	[rpm]	[Nm]	[Nm]	[Nm]	[Nm]	[Nm]	[Nm]	[Nm]	[Nm]	[Nm]	[Nm]	[Nm]	[Nm]	[Nm]	[Nm]	[Nm]	[Nm]
TMX140050D.. Water cooled	1500	33						51	57	57							
TMX140070C.. Water cooled	1500	50								81	81	81					
TMX210070I.. Water cooled	500	174								350	350	350					
TMX291050H.. Water cooled	500	230								360	360	435	435				
TMX291070I.. Water cooled	500	325										560	560	610			



General Description

AMS Motor Power vs Speed and Torque vs Speed Characteristics

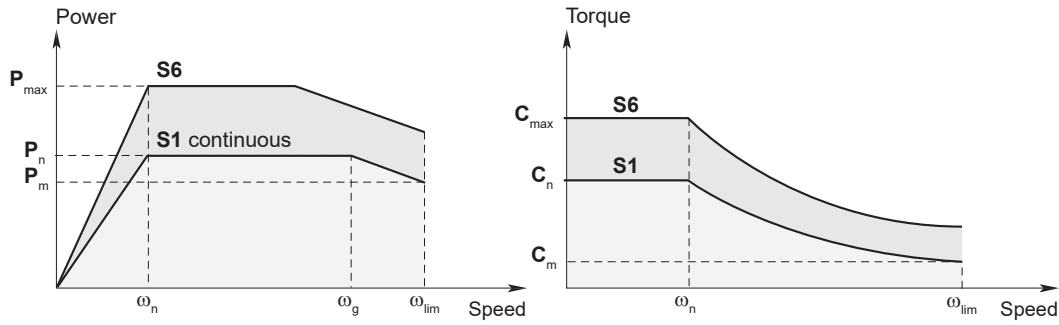

- P_n = Rated continuous power (S1)
- P_{max} = Overload power (S6)
- P_m = Continuous power at maximum speed (S1)
- ω_n = Rated speed
- C_n = Rated torque
- C_{max} = Overload torque (S6)
- C_m = Continuous torque at maximum speed (S1)
- ω_g = Maximum speed at constant power (S1)
- ω_{lim} = Maximum speed
- I_{cont} = Rated continuous current (S1)
- I_{ms} = Overload current with the associated drive (S6)

7

Services

	S2	S3	S6
Load			
Electrical losses			
Temperature			
Time	—	$f_m = \frac{N}{N+R} \times 100 (\%)$	$f_m = \frac{N}{N+V} \times 100 (\%)$

- N** = Operation at power P_{max}
- R** = Idle
- V** = Off-load operation
- f_m = Duty cycle

Motor/Drive Associations

Spindle Motors

Association of AMS and IM Spindle Motors with NUMDrive X

Association of AMS Motors with NUMDrive X (Switching Frequency 5 kHz)

AMS...		Connection	MDLUX... 5 kHz	Continuous operation S1							Overload S6												
				Pn	ω_n	ω_g	ω_{lim}	Pm	Cn	Icont	Pmax	Cmax	Ims	10 min									
				(kW)	(rpm)	(rpm)	(rpm)	(kW)	(Nm)	(Arms)	(kW)	(Nm)	(Arms)	(%)									
100	SB	Y	050A	3.7	1 500	6 500	6 500	3.7	24	20	6	40	35	22									
			050B												15 *								
	MB	Y	075A												5.5	10	80	53	13				
			075B																				
	GB	Y	100A												9	17	120	71	16				
	SD	Y	050A												3.7	12 000	1.8	24	20	6	40	35	22
			050B																				
	MD	Y	075A																				
075B																							
GD	Y	100A	9	17	120	71	16																
132	SA	Y	075A	5	750	6 000	7 000	2.8	64	26	10	150	53	16									
			075B																				
	SC	Y	100A	10	1 500	8	64	39	19	122	71	20											
	SE	Δ	150A	15	1 750	4 000	10	82	52	29	160	106	13										
	MA	Y	100A	7.5	750	6 000	5.7	95	39	15	190	71	20										
	MC	Y	150A	15	1 500	12.5								52	30	190	106	16					
	ME	Δ	200A	19.5	2 000	6 500	19	100	72	35	149	106	30										
	LA	Y	150A	11	750	6 000	9	140	52	23	292	106	16										
	LE	Y	200A	22	1 250	4 200	15	168	72	36	229	106	30										
	SF	Y	075A	5	750	6 000	10 000	2	64	26	10	150	53	16									
			075B																				
	SG	Y	100A	10	1 500	6	39	19	122	71	20												
	SH	Δ	150A	15	1 750	4 000	7.5	82	52	29	160	106	13										
	MF	Y	100A	7.5	750	6 000	4	95	39	15	190	71	20										
	MG	Y	150A	15	1 500	52								30	190	106	16						
	MH	Δ	200A	19.5	2 000	6 500	13.5	93	72	35	149	106	30										
	LF	Y	150A	11	750	6 000	9 000	7	140	52	23	292	106	16									
	LI	Y	100A	12.5	680	2 300	3	175	39	19	270	71	16										
LH	Y	200A	22	1 250	4 200	12	168	72	36	229	106	30											
160	MA	Y	150A	18	650	1 300	8 500	2.7	264	52	29	570	106	15									
															Δ	1 300	2 600	5.4	132	29	255	106	15
	MB	Y	200A	26	1 200	2 400	7.3	208	72	36	290	106	35										
														Δ	2 400	5 500	14.5	104	36	145	106	35	
	MC	Δ	200A	36	1 700	2 800	11.8	202	100	47	265	141	10										
	LA	Y	150A	18	500	1 000	6 500	2.8	344	52	27	740	106	15									
															Δ	1 000	2 500	5.6	172	27	400	106	15
	LB	Y	200A	26	950	1 900	7.6	260	72	36.4	364	106	35										
Δ														1 900	4 000	15.2	130	36.4	182	106	35		
LC	Δ	200A	36	1 050	2 100	11.6	328	100	48	437	141	10											

* Performance limited by drive type association (Bi-Axes drive)

Motor/Drive Associations

Spindle Motors

Association of AMS and IM Spindle Motors with NUMDrive X



Association of IM Motor with NUMDrive X (Switching Frequency 5 kHz)

IM ...	Connection	MDLUX...	Continuous operation S1							Overload S6			
			Pn	wn	wg	wlim	Pm	Cn	Icont	Pmax	Cmax	Ims	10 min
			(kW)	(rpm)	(rpm)	(rpm)	(kW)	(Nm)	(A _{rms})	(kW)	(Nm)	(A _{rms})	(%)
18MK14	YY	400A	55	1 050	2 100	7 500	16.5	500	145	76	690	200	40

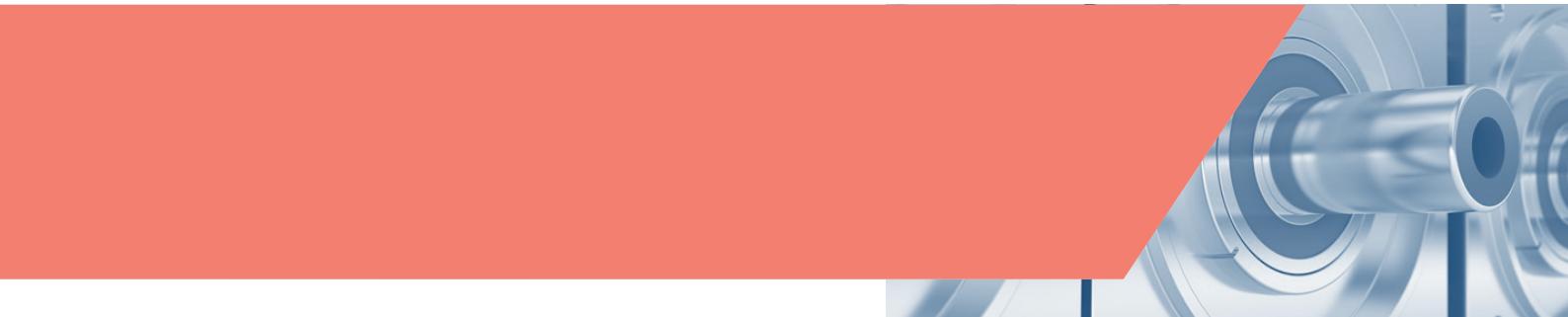

Description

NUMDrive X

The modern design of NUMDrive X servo drives makes them the ideal counterpart to the powerful Flexium⁺ CNC.

One distinguishing feature of the NUMDrive X is its high power density. The servo drives offer an enormous amount of computing and drive power within a very small space and thus have one of the highest power/volume ratios available. A high degree of integration and efficiency has allowed us to achieve an extremely compact design that makes NUMDrive X one of the smallest high-end drives on the market. Thanks to a small depth and a modular width (a multiple of 50 mm) the cabinet layout is greatly simplified.

The range is characterized by a wide choice of current from a few amperes up to 282 Arms, Bi-Axes versions are available up to 2x 53 Arms to enable each application to be optimized at the lowest cost. For the maximum contour precision, speeds and cost-effectiveness, the NUMDrive X servo drives can be exactly adapted to the particular machine and application.

NUMDrive X is a modular system that is optimized for multi-axes applications. Use of a common power supply unit means that only one mains connection, one line filter and one braking resistor are required per system, reducing cabling and overall costs. The system's modularity also facilitates energy exchange between different axes via the DC bus, offers the possibility of using stored energy for retraction purposes, and – in the case of regenerative power supplies – allows energy to be re-injected into the mains to reduce machine operating cost. Such system conception also leads the way for a greener approach.

NUMDrive X offers a choice of two performance levels:

- Standard-Performance (SP) drives
- High-Performance (HP) drives

Featuring high internal resolution, a short sampling time and specially developed algorithms, the HP versions are designed for sophisticated and complex applications in precision machine tools. The position control loop is closed with a very high bandwidth, achieving exceptional precision and speed at the mechanical interface of the machine (motor axis, linear motor). NUMDrive X accepts almost all measuring systems and can control a broad range of motors (servo, torque, linear, asynchronous motors) from NUM or other manufacturers. This ensures that a solution can be optimized from the technical and economic perspectives.

The HP versions of NUMDrive X also incorporate unique functionality known as DEMX (Drive Embedded Macro). This allows users to create their own real-time macro which can interact with all physical and virtual drive resources – even to the extent of manipulating the regulation algorithms. Users can design and implement filters and monitors, define test points and create pilot outputs that obey user-stipulated rules.

The SP versions of NUMDrive X are suited to systems and precision machine tools of medium complexity, as well as cost-sensitive applications.

Within the NUMSafe architecture, NUMDrive X provides the safe motion functionalities by means of two different modules:

- NUM-STOX is the basic module for implementing the Safe Torque Off function certified up to SIL 3 according to IEC 61508. This allows the re-alization of E-STOP functions category 0 and 1 according to EN60204-1
- NUM-SAMX is the extended functionality module which provides a huge number of safe motion monitoring functions. STO Safe Torque Off, SLS Safely Limited Speed, SOS Safe Operational Stop, SS1 Safe Stop 1, SS2 Safe Stop 2, SLP Safe Limited Position, SDM (Safe Direction Monitoring) and SCA Safe CAMs

Every machine builder has experienced the complexity of encoder wiring and knows that it takes time and effort to install and debug satisfactorily. NUMDrive X introduces a revolutionary innovation to overcome these issues. The drive incorporates a full digital encoder interface which uses a two-wire communication protocol. The two wires are integrated in the power cable. For more detailed characteristics on such encoders please refer to the Motors chapter.

For controlling auxiliary axes or auxiliary spindles, the NUMDrive C with CANopen interface is the most suitable solution. The CAN interface complies with a subset of the Device Profile DS402. The EDS (Electronic Data Sheet) files are available for the application of Mono-Axis and Bi-Axes versions.

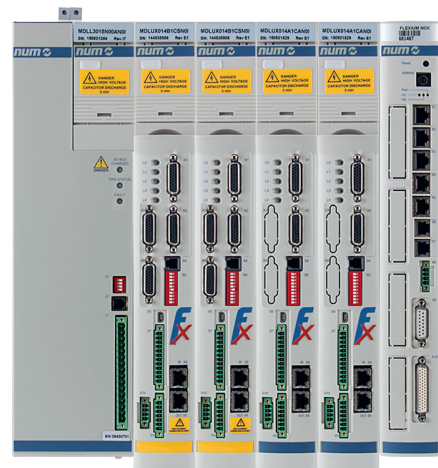

System Overview

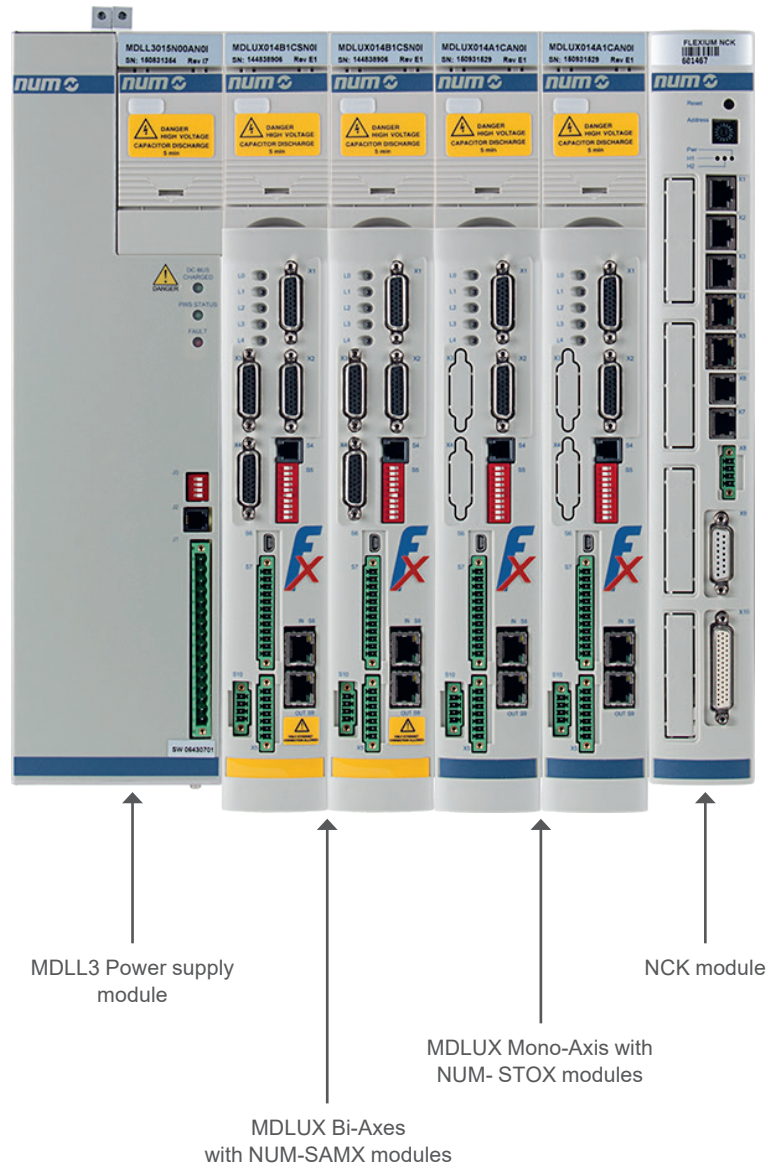

MDLUX general description (i.e. High Performance Bi-Axes module with NUM-SAMX)

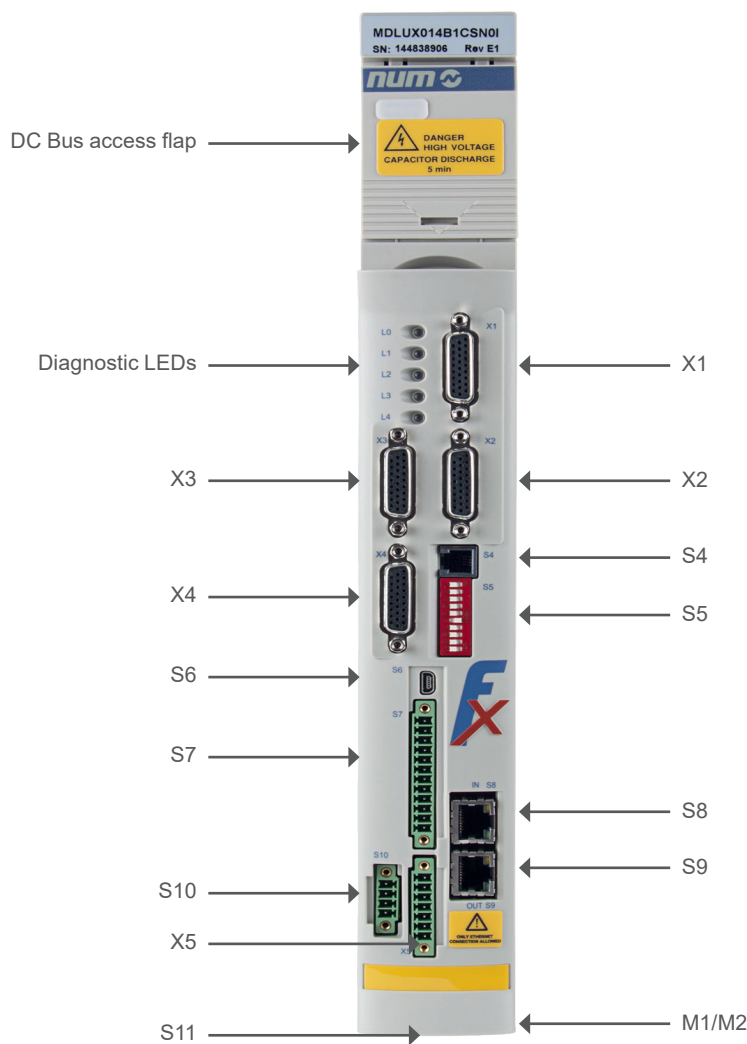

X1	Sub D HD 26 pins F	Motor sensor (Axis1) connections
X2	Sub D HD 26 pins F	Motor sensor (Axis2) connections
X3	Sub D HD 26 pins F	Direct measure (Axis1) connections
X4	Sub D HD 26 pins F	Direct measure (Axis2) connections
X5	7 screws pins	2-wires encoder connections for Motor 1 / Motor 2
S4	RJ10 (4P/4C)	WPMX tool connection
S5	Dip switches (x10)	Physical address axis / spindle digital bus 1&2
S6	Mini USB	WPMX tool connection
S7	12 screws pins	+24 VDC customer, programmable IN/OUT, General purpose input
S8, S9	RJ45 (8P/8C)	EtherCAT NUM-SAMX connection
S10	4 screws pins	Motors brake control
S11	2x HDMI F	Module/module DISC NT+ digital bus interconnections
M1/M2	6 pins screws	Motor power and brake connector AEOCON018

General Characteristics

Power Supply AC/DC Converter <ul style="list-style-type: none"> • Input Voltage • Input Frequency • Rated Power • Dissipation of Braking Energy 	400 Vrms -10% to 480 Vrms +6% 3 phases 50/60Hz ± 5% from 15 kW up to 120 kW continuous power reinjection in mains or braking resistors
Rated Output Current (DC/AC Converter)	from 4.2 Arms up to 282 Arms continuous current
Environment Storage Conditions <ul style="list-style-type: none"> • Temperature Range • Relative Humidity 	0 to + 70°C max. 75% without condensation
Environment Working Conditions <ul style="list-style-type: none"> • Temperature Range • Relative Humidity • Vibration Stressing • Altitude • Pollution Degree • Electromagnetic Compatibility 	0 to 40°C without derating, max 60°C with derating max. 75% without condensation Complies with EN 61800-5-1 0 to 1000 m without derating, max 3000 m with derating 2, installation category II Conforms to EN 61800-3
Functional Safety with NUM-SAMX <ul style="list-style-type: none"> • Safety Integrity Level (SIL) • PL 	up to 3 (IEC61800-5-2) e (EN13849-1)
Functional Safety with NUM-STOX <ul style="list-style-type: none"> • Safety Integrity Level (SIL) • PL 	up to 3 (IEC61800-5-2) d (EN13849-1)

Power Supply Technical Characteristics (MDLL)

MDLL power supplies are designed to be used in conjunction with NUMDrive C and NUMDrive X. MDLLs supply the DC bus voltage and the control voltage (auxiliary voltage).

MDLLs are available in various power ratings and with dissipation of the braking energy by external resistor or with reinjection into the mains.

MDLQ is an auxiliary power supply used whenever the available built-in auxiliary power of the MDLL isn't sufficient (high number of drives). Refer to the installation manual for more information.

Passive Power Supply

MDLL3 Power Supplies		MDLL3015N00AN0I	MDLL3030N00AN0I	MDLL3050N00AN0I	MDLL3120N00AN0I
Rated Power (S1)	kW	15	30	50	120
S3 Power (4s ON - 6s OFF)	kW	40	45	97	150
Peak Power	kW	50	50	97	175
Maximum Continuous Braking Power	kW	15	30	20	20
Peak Braking Power	kW	51	61	120	170
Rated Input Voltage	V	400 Vrms -10% to 480 Vrms +6% 50/60Hz ± 5% 3 phases			
Rated Input Current	Arms	31	62	100	194
DC Bus Voltage at Rated Power	VDC	540 VDC with 400 Vrms input, 650 VDC with 480 Vrms input			
Dissipation of Braking Energy		On external braking resistor			
Auxiliary Rated Power	W	230		180	200
Protection Degree (EN60529)		IP20		IP00	
Overall Dimensions (WxHxD)	mm	100 x 355 x 206		200 x 355 x 206	300 x 355 x 206
Weight	kg	5.5		11.5	19

Regenerative Power Supply

MDLL3 Power Supplies		MDLL3025N00RN0I	MDLL3050N00RN0I	MDLL3120N00RN0I
Rated Power (S1)	kW	25	50	120
S3 Power (4s ON - 6s OFF)	kW	50	97	150
Peak Power	kW	50	97	175
Maximum Continuous Braking Power	kW	25	50	120
Peak Braking Power	kW	61	120	170
Rated Input Voltage	V	400 Vrms -10% to 480 Vrms +6% 50/60Hz ± 5% 3 phases		
Rated Input Current	Arms	50	100	194
DC Bus Voltage at Rated Power	VDC	540 VDC with 400 Vrms input, 650 VDC with 480 Vrms input		
Dissipation of Braking Energy		Reinjection in mains		
Auxiliary Rated Power	W	180		200
Protection Degree (EN60529)		IP00		
Overall Dimensions (WxHxD)	mm	200 x 355 x 206		300 x 355 x 206
Weight	kg	11.5		19

Regenerative Power Supply with controlled DC Bus Voltage

MDLL3 Power Supplies		MDLL3025N00HN0I	MDLL3050N00HN0I	MDLL3120N00HN0I
Rated Power (S1)	kW	25	50	120
S3 Power (4s ON - 6s OFF)	kW	50	97	150
Peak Power	kW	50	97	190
Maximum Continuous Braking Power	kW	25	50	120
Peak Braking Power	kW	61	120	200
Rated Input Voltage	V	400 Vrms -10% to 480 Vrms +6% 50/60Hz ± 5% 3 phases		
Rated Input Current	Arms	36	72	173
DC Bus Voltage at Rated Power	VDC	Configurable DC Bus voltage: 600, 650, 700 VDC		
Dissipation of Braking Energy		Reinjection in mains		
Auxiliary Rated Power	W	180		200
Protection Degree (EN60529)		IP00		
Overall Dimensions (WxHxD)	mm	200 x 355 x 206		300 x 355 x 206
Weight	kg	11.5		19

Passive Power Supply single phase 230 Vrms

MDLL3 Power Supplies		MDLL3005M00AN0I
Rated Power (S1)	kW	5
S3 Power (4s ON - 6s OFF)	kW	6
Peak Power	kW	6
Maximum Continuous Braking Power	kW	5
Peak Braking Power	kW	9
Rated Input Voltage	V	230Vrms -10% + 230Vrms +10% (Single-phase)
Rated Input Current	Arms	31
DC Bus Voltage at Rated Power	VDC	300 VDC with 230Vrms input
Dissipation of Braking Energy		On braking resistor
Auxiliary Rated Power	W	200
Protection Degree (EN60529)		IP20
Overall Dimensions (WxHxD)	mm	100 x 355 x 206
Weight	kg	5.5

Auxiliary Power Supply for Control Voltage

MDLQ3 Power Supply		MDLQ3001N00
Auxiliary Rated Power	W	250
Input Voltage	V	400 Vrms -10% to 480 Vrms +6% 50/60Hz ± 5% 2 phases
Protection Degree (EN60529)		IP20
Overall Dimensions (WxHxD)	mm	50 x 355 x 206
Weight	kg	2.8

The MDLQ auxiliary power supply is only required if the MDLL's auxiliary output has insufficient power to meet the control voltage supply needs of the complete drive line-up. See installation manual M00030 for details.

Servo Drive Interoperability and Functions (MDLUX)

		Bi-Axes SP	Mono-Axis HP	Bi-Axes HP
Interface	High speed digital bus DISC NT+	●	●	●
Control Performance	Standard performance control loops	●	●	●
	High performance control loops	-	●	●
Compatible Motors	Closed loop: synchronous rotary motors	● ¹	●	●
	Closed loop: synchronous torque and linear motors	-	●	●
	Closed loop: asynchronous motors	●	●	●
	Open loop: asynchronous motors (V/F mode)	●	●	●
Compatible Motor Sensor	Single cable motor encoder (SHX, SPX motors)	●	●	●
	EnDat 2.1 & EnDat 2.2 encoder	●	●	●
	1 Vpp toothed wheel / encoder	●	●	●
	Renishaw RESOLUTE™ encoders with BiSS interface	●	●	●
	Magnescape encoders	●	●	●
Compatible Direct Measure Sensors	EnDat 2.1 & EnDat 2.2 encoder / linear scale	-	●	●
	Hall sensors	-	●	●
	1 Vpp encoder / linear scale (also with coded references)	-	●	●
	Renishaw RESOLUTE™ encoder with BiSS interface	-	●	●
	Magnescape encoders	-	●	●
Special Functions	Spindle operation for synchronous and asynchronous motors	●	●	●
	Synchronous motor phasing without movement	●	●	●
	Spindle-Axis commutation	-	●	●
	Star/Delta commutation on the fly (for asynchronous motor)	-	●	●
	Rotary axis with mechanical ratio not 2 ⁿ	●	●	●
	AP03: Anti-backlash function	-	○	○
	AP04: Torque duplication	-	○	○
	AP05: Winding duplication	-	○	○
	DEMX: Drive Embedded Macro ²	-	○	○
	Coherence control between motor and direct measure sensor	-	●	●
Various active damping functions	-	●	●	
Various freely settable filters	●	●	●	
EPS: Electrical Position Synchronization	-	●	●	
AP01: Absolute position with motor's multi-turn encoder and incremental direct measure sensor	-	●	●	

¹ for standard performance, max. 8 pole pairs motors

² Subject to international export control

● Standard ○ Optional - Not Available

Servo Drive Interoperability and Functions (MDLUX)





		Bi-Axes SP	Mono-Axis HP	Bi-Axes HP
Safety Functions Compliant with EN 61800-5-2	NUM-STOX module with Safe Torque Off	○	○	○
	NUM-SAMX module with	○	○	○
	• STO Safe Torque Off			
	• SLS Safely Limited Speed			
	• SOS Safe Operational Stop			
	• SS1 Safe Stop 1			
	• SS2 Safe Stop 2			
	• SLP Safe Limited Position			
	• SDM Safe Direction Monitoring			
	• SCA Safe CAMs			

● Standard ○ Optional - Not Available

Servo Drive Technical Characteristics (MDLUX)

MDLUX servo drive modules must always be selected to suit the associated motor. They are available in 15 ratings as shown below.

All MDLUX modules have the same depth and height, and their width varies in standard modular increments (multiples of 50mm), allowing easy mounting in electrical cabinets. A built-in brake management scheme eliminates the need for an external control relay.

MDLUX Module Size	Type	Reference	Rated Current	Maximum Current
Size 1, 50mm 	Mono-Axis	MDLUX007A1xxN0I MDLUX014A1xxN0I MDLUX021A1xxN0I MDLUX034A1xxN0I	4.4 Arms 8.9 Arms 13 Arms 13 Arms	5 Arms 10 Arms 15 Arms 24 Arms
	Bi-Axes	MDLUX007B1xxN0I MDLUX014B1xxN0I MDLUX021B1xxN0I	3.1 + 3.1 Arms 6.3 + 6.3 Arms 6.3 + 6.3 Arms	5 + 5 Arms 10 + 10 Arms 15 + 15 Arms
Size 2, 100mm 	Mono-Axis	MDLUX050A1xxN0I MDLUX075A1xxN0I	28 Arms 34 Arms	35 Arms 53 Arms
	Bi-Axes	MDLUX050B1xxN0I	20 + 20 Arms	35 + 35 Arms
Size 3, 150mm 	Mono-Axis	MDLUX100A1xxN0I MDLUX150A1xxN0I	45 Arms 60 Arms	71 Arms 106 Arms
	Bi-Axes	MDLUX075B1xxN0I	29 + 29 Arms	53 + 53 Arms
Size 4, 200mm 	Mono-Axis	MDLUX200A1xxN0I	100 Arms	141 Arms
Size 6, 300mm 	Mono-Axis	MDLUX400A1xxN0I	200 Arms	282 Arms

Mono-Axis Drive up to 50A

Mono-Axis		MDLUX007A		MDLUX014A...		MDLUX021A...		MDLUX034A...		MDLUX050A...	
Switching Frequency	kHz	5.0	10.0	5.0	10	5	10	5	10	5	10
Rated Current (S1)	Arms	4.4	4.4	8.9	6	13	8	13	8	28	18
Maximum Current	Arms	5		10		15		24		35	
Auxiliary Power Consumption ¹	W	18.5								22.5	
Protection Degree (EN60529)		IP20									
Overall Dimensions (WxHxD)	mm	50x355x206								100x355x206	
Weight	kg	3								5.9	

Mono-Axis Drive up to 400A

Mono-Axis		MDLUX075A...		MDLUX100A...		MDLUX150A...		MDLUX200A...		MDLUX400A...	
Switching Frequency	kHz	5	10	5	10	5	10	5	10	5	10
Rated Current (S1)	Arms	34	23	45	34	60	40	100	70	200	130
Maximum Current	Arms	53		71		106		141		282	
Auxiliary Power Consumption ¹	W	22.5		32		32		42.5		27.5	
Protection Degree (EN60529)		IP20		IP00							
Overall Dimensions (WxHxD)	mm	100 x 355 x 206		150 x 355 x 206				200 x 355 x 206		300 x 355 206	
Weight	kg	5.9		8.2				11		15	

Bi-Axes Drive

Bi-Axes		MDLUX007B...		MDLUX014B...		MDLUX021B...		MDLUX050B...		MDLUX075B...	
Switching Frequency	kHz	5	10	5	10	5	10	5	10	5	10
Rated Current (S1)	Arms	3.1+3.1	3.1+3.1	6.3+6.3	4.2+4.2	6.3+6.3	4.2+4.2	20+20	13+13	29+29	20+20
Maximum Current	Arms	5+5		10+10		15+15		35 + 35		53+53	
Auxiliary Power Consumption ¹	W	21.5						28.5		35	
Protection Degree (EN60529)		IP20									
Overall Dimensions (WxHxD)	mm	50 x 355 x 206						100 x 355 x 206		150 x 355 x 206	
Weight	kg	3						6.2		8.2	

¹ Without considering sensor power supply. Add 1W for each connected sensor (motor or direct).

Refer to installation manual for more information and dimensioning rules.

NUMDrive X

Servo Drive and Power Supply

Outlines Size 1

MDLUX & MDLL Outlines (Size 1)

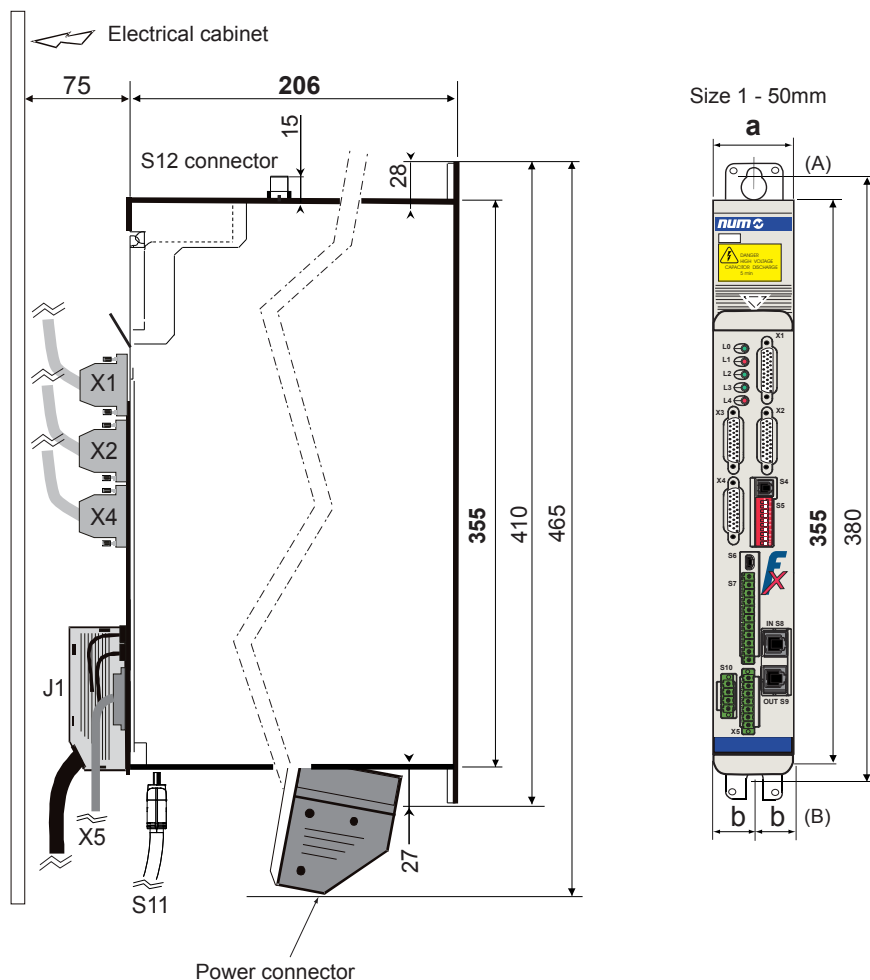

8

Module Description	Code	Module Size	Dimensions	
			a	b
NUMDrive X Modules	MDLUX007A1xxN0I MDLUX014A1xxN0I MDLUX021A1xxN0I MDLUX034A1xxN0I MDLUX007B0xxN0I MDLUX014B1xxN0I MDLUX021B1xxN0I	Size 1 - 50mm	50	25
Additional 250W AUX Module	MDLQ3001N00			

NUMDrive X

Servo Drive and Power Supply

Outlines Size 2

MDLUX & MDLL Outlines (Size 2)

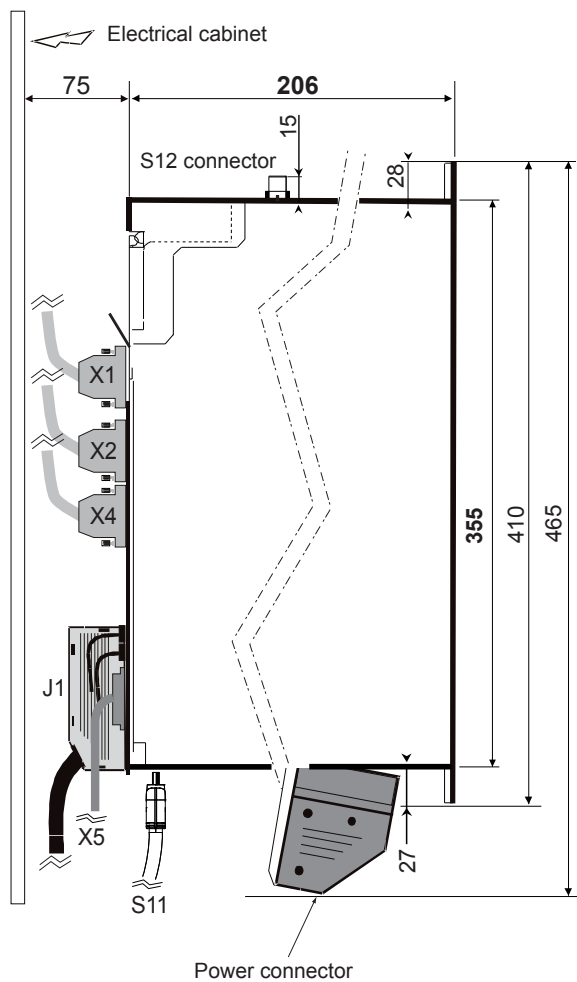

Size 2 - 100mm

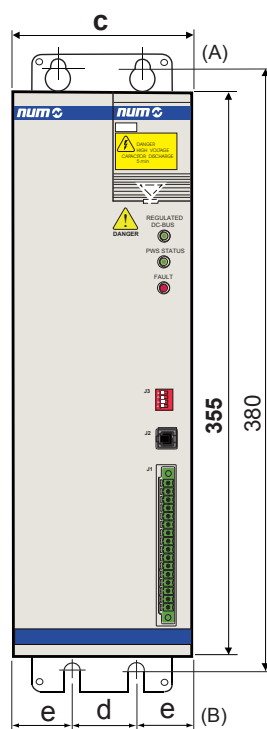

Module Description	Code	Module Size	Dimensions		
			c	d	e
MDLL3 Module	MDLL3015N00AN0I MDLL3030N00AN0I MDLL3005N00AN0I MDLC3010N00	Size 2 - 100mm	100	50	25
NUMDrive X Modules	MDLUX050A1xxN0I MDLUX075A1xxN0I MDLUX050B1xxN0I				

NUMDrive X

Servo Drive and Power Supply
Outlines Size 3

MDLUX Outlines (Size 3)

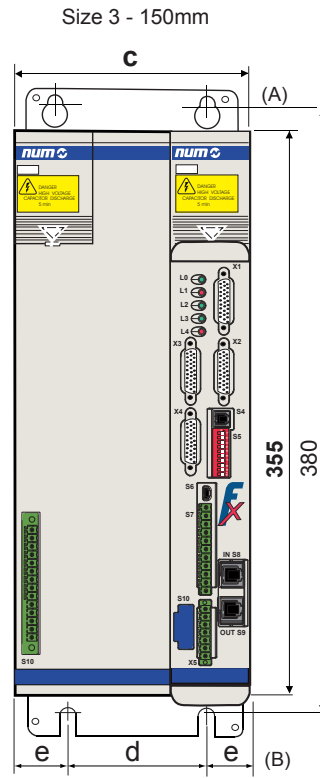
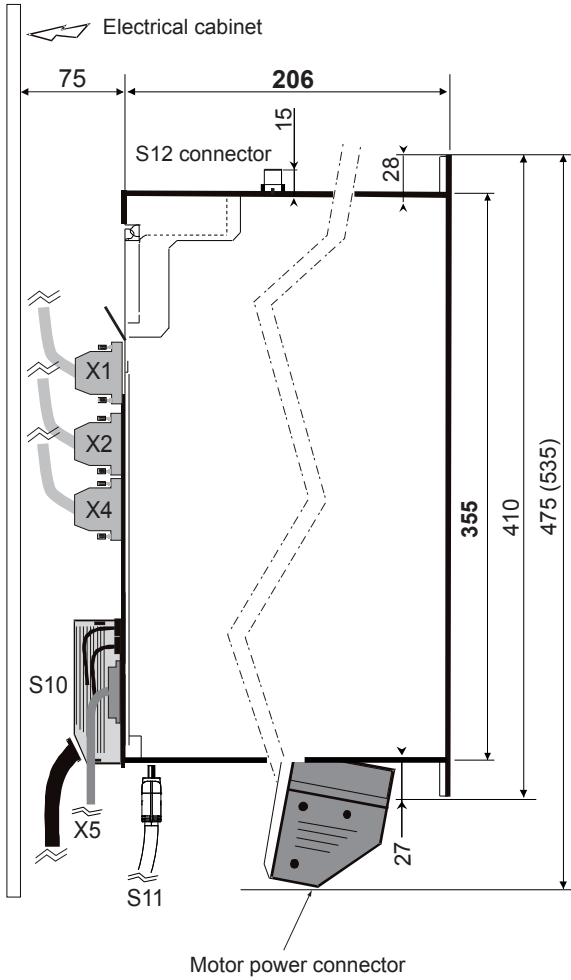

8

Module Description	Code	Module Size	Dimensions				
			a	b	c	d	e
NUMDrive X Modules	MDLUX100A1xxN0I MDLUX150A1xxN0I MDLUX075B1xxN0I	Size 3 - 150mm	50	25	150	100	25

NUMDrive X

Servo Drive and Power Supply
Outlines Size 4

MDLUX & MDLL Outlines (Size 4)

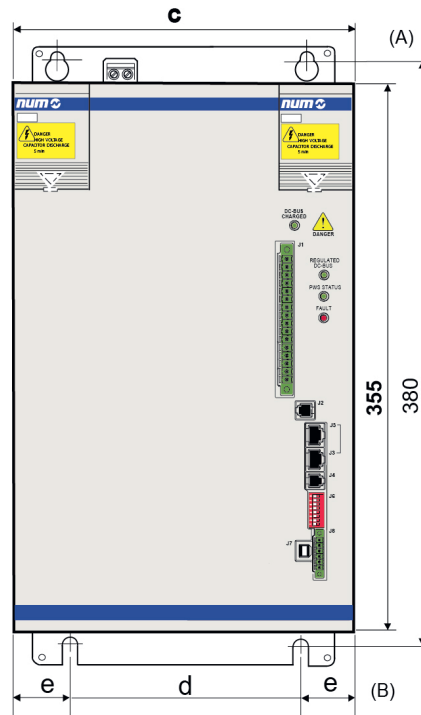
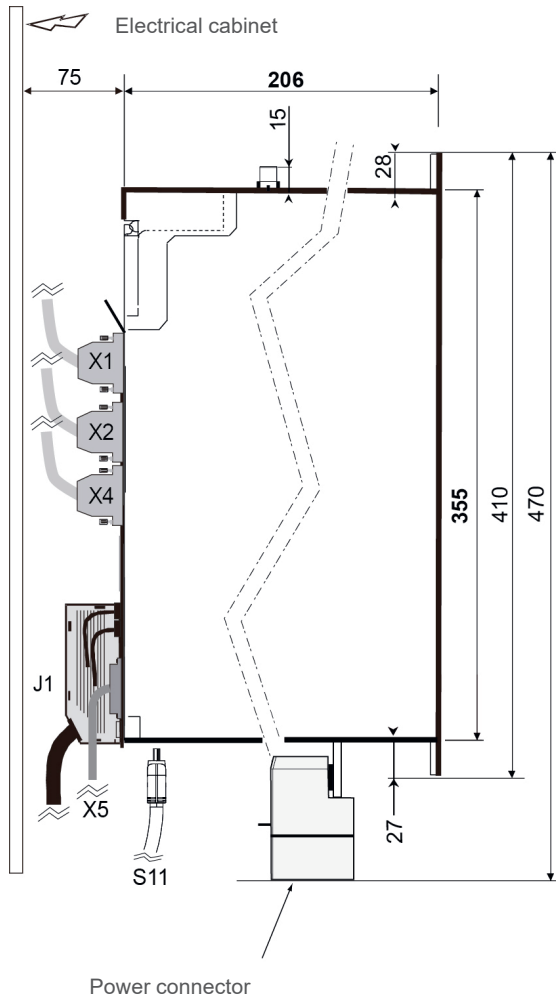

Module Description	Code	Module Size	Dimensions				
			a	b	c	d	e
MDLL3 Module	MDLL3025N00RN0I MDLL3050N00RN0I MDLL3025N00HN0I MDLL3050N00HN0I MDLL3050N00AN0I	Size 4 - 200mm	50	25	200	150	25
NUMDrive X Modules	MDLUX200A1xxN0I						

NUMDrive X

Servo Drive and Power Supply
Outlines Size 6

MDLUX & MDLL Outlines (Size 6)

MDLL3 and MDLUX size 6 overall dimensions
(with fan and metallic plate)

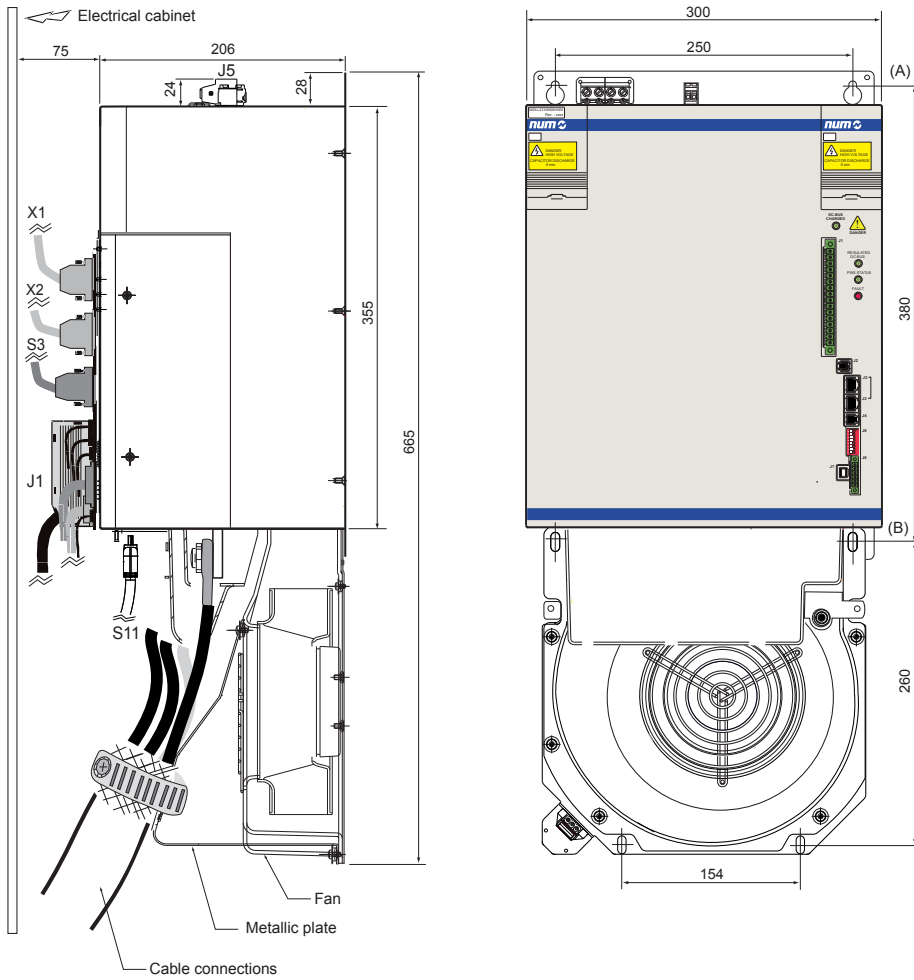

8

Module Description	Code	Module Size
MDLL3 Module	MDLL3120N00AN0I MDLL3120N00RN0I MDLL3120N00HN0I	Size 6 - 300mm
NUMDrive X Modules	MDLUX400A1xxN0I	

Power Supply

	MDLL	3	015	N	00	A	N	0	I
Series									
Evolution Index									
Rated Power									
• Size 2: Pn 5kW			005						
• Size 2: Pn 15kW			015						
• Size 2: Pn 30kW			030						
• Size 4: Pn 25kW			025						
• Size 4: Pn 50kW			050						
• Size 6: Pn 120kW ⁶			120						
Mains Supply									
• From 230Vac -10% to 230Vac +6% 50/60Hz +/-5%, Single phase				M ¹					
• From 400Vac -10% to 480Vac +6% 50/60Hz +/-5%, 3 phases				N ²					
Options									
• None					00				
Type									
• Passive power supply ^{3,4}						A			
• Regenerative power supply ^{3,5}						R			
• Regulated DCBus power supply ^{3,5}						H			
Version									
• Standard NUM							N		
Standard NUM								0	
Heat-Sink Position									
• Internal heat-sink									I

¹ Available only on Pn 5kW rated power

² Not available on Pn 5kW rated power

³ An external braking resistor must be always used

⁴ Not available on Pn 25kW

⁵ Not available on Pn 5kW, Pn 15kW and Pn 30kW rated power

⁶ An external fan AGOFAN001 + AEOKIT003 must be always taken in account

Servo Drive

	MDLUX	014	A	1	C	F	N	0	I
Series									
Rated Power									
Mono-Axis									
• Size 1: In 4.4Arms, Ipeak 5Arms		007							
• Size 1: In 8.9Arms, Ipeak 10Arms		014							
• Size 1: In 13Arms, Ipeak 15Arms		021							
• Size 1: In 13Arms, Ipeak 24Arms		034							
• Size 2: In 28Arms, Ipeak 35Arms		050							
• Size 2: In 34Arms, Ipeak 53Arms		075							
• Size 3: In 45Arms, Ipeak 71Arms		100							
• Size 3: In 60Arms, Ipeak 106Arms		150							
• Size 4: In 100Arms, Ipeak 141Arms		200							
• Size 6: In 200Arms, Ipeak 282Arms ¹		400							
Bi-Axes									
• Size 1: In 3.1+3.1Arms, Ipeak 5+5Arms		007							
• Size 1: In 6.3+6.3Arms, Ipeak 10+10Arms		014							
• Size 1: In 6.3+6.3Arms, Ipeak 15+15Arms		021							
• Size 2: In 20+20Arms, Ipeak 35+35Arms		050							
• Size 3: In 29+29Arms, Ipeak 53+53Arms		075							
Axis Number									
• Mono-Axis			A						
• Bi-Axes			B						
Communication									
• DISC NT+ ²				1					
Version									
• Standard Performance ³					A				
• High Performance					C				
• High Performance with external link ⁴					D				
Safety									
• Without Safety module						A			
• Certified NUM-STOX (Safe Torque Off) module according to EN61800-5-2 up to SIL 3						E			
• Certified NUM-SAMX G2 Safety module according to EN61800-5-2 up to SIL 3						F			
Standard NUM							N		
Fixed Value								0	
Heat-Sink Position									I
• Internal heat-sink									I

¹ An external AGOFAN001 and AEOKIT005 must be always taken in account

² DISC NT+ bus HDMI-HDMI cable connection AEOFRU015Mxxxx must be always taken in account for each drive, because it has been remove from the customer connection. One AEOFRU011Mxxxx DB25-HDMI cable must be always taken in account for the first drive located on the right of the power supply. One FXHC08152x HDMI-RJ45 cable must be always taken in account for the last drive to be connected with the NCK module

³ Not available with Mono-Axis version

⁴ Not available for Bi-Axes version, required for Mono-Axis tandem function



General Characteristics

NUM's EtherCAT Terminal is a modular system available with different configurable devices:

- Gateway modules CTMG1100
- Extension modules CTMG1110
- Digital and Analogue I/O modules CTMTxxxx
- Safe PLC modules CTMP6900 and CTMP1960-2600 ¹
- Safe I/O modules CTMS1904, CTMS2904 and CTMS2912
- Technology modules CTMTxxxx

Machine builders can easily create their own configurations from a mix of different devices. Each line-up requires a gateway to receive messages from the EtherCAT field bus and propagate them to the different devices via the internal E-bus. Please also refer to chapter 2 for further information on NUM's EtherCAT process and terminal combinations.

NUM EtherCAT Terminals Mixed Combination

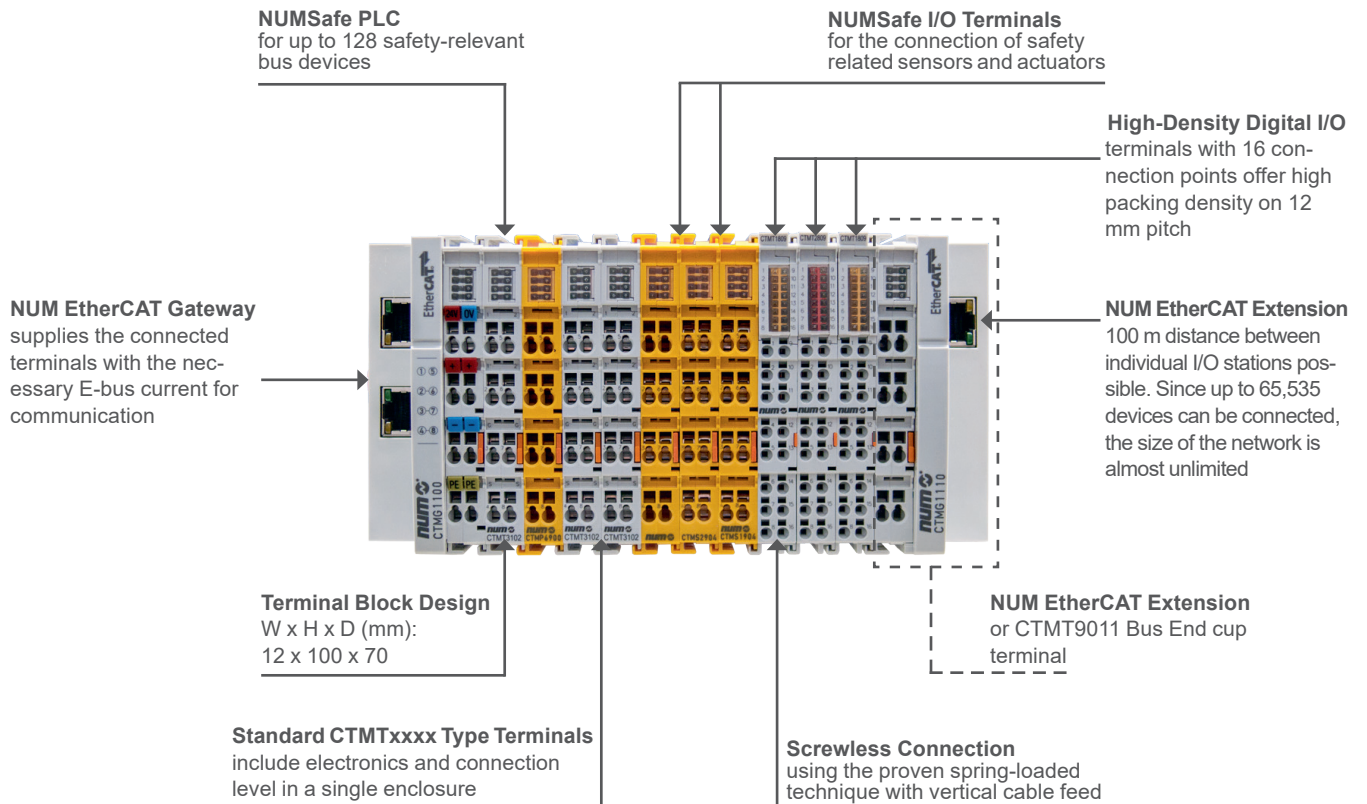

¹ For more detailed information on the Safe PLC and Safe I/O modules please refer to the M00033, M00034 and M00035 manuals.



Structure

Robust housings, secure contacts and solidly built electronics are prominent features of NUM components. An I/O station consists of an EtherCAT Gateway and almost any number of terminals. Since up to 65,535 devices can be connected, the size of the network is almost unlimited. The electronic terminal blocks are attached to the EtherCAT Gateway. The contacts are made as the terminal clicks into place, without any other manipulation.

This means that each electronic terminal block can be individually exchanged. It can be placed on a standard DIN rail.

A clearly arranged connection panel with LEDs for status display and push-in contact labels ensures clarity in the field. 3-wire conductors with an additional connection for a protective conductor, enable direct connection of sensors and actuators.

Free Mix of Signals

Suitable EtherCAT Terminals are available for all common digital and analog signal types encountered in the world of automation. NUM EtherCAT Terminals enable bit-precise composition of the required I/O channels.

The digital EtherCAT Terminals are designed as 2-, 4-, 8- or 16-channel terminals.

In the 16-channel variant, digital input and output signals are arranged in an ultra-compact way within a standard terminal housing across a width of only 12mm. The standard analog signals of ± 10 V, 0...10 V, 0...20mA and 4...20mA are all available as 1-, 2-, 4- and 8-channel variants within a standard housing.



Gateways and Terminals

Description	Commercial Reference	Task / Connection Technology	E-bus Power Consumption [mA]
Gateway EtherCAT gateway EtherCAT extension	CTMG1100 CTMG1110	Connects EtherCAT with terminal Extends EtherCAT connection	70 130
Digital Input 4-channel digital input terminal 24 VDC, 3 ms 8-channel digital input terminal 24 VDC, 3 ms HD EtherCAT Terminal, 4-channel digital input 24 VDC HD EtherCAT Terminal, 16-channel digital input 24 VDC	CTMT1004 CTMT1008 CTMT1804 CTMT1809	2-wire connection 1-wire connection 3-wire connection 1-wire connection	90 90 100 100
Digital Inputs and Outputs EtherCAT Terminal, 8 digital Input- and Output channels	CTMT1859	1-wire connection	130
Digital Output 4-channel digital output terminal 24 VDC, 0.5 A 8-channel digital output terminal 24 VDC, 0.5 A 4-channel digital output terminal 24 VDC, 2A 2-channel relay output terminal 230 VAC, 2A 2-channel relay output terminal, 125 VAC, 1A HD EtherCAT Terminal, 16-channel digital output 24 VDC, 0.5 A	CTMT2004 CTMT2008 CTMT2024 CTMT2602 CTMT2612 CTMT2809	2-wire connection 1-wire connection 2-wire connection Relay output 1-wire connection Relay output 1-wire connection	100 110 110 170 150 140
Analog Input 2-channel analog input terminal -10...+10 V, differential input, 16 bits 2-channel analog input terminal 4...20 mA, differential input, 16 bits 2-channel analog input terminal 0...10 V, single-ended, 16 bits 2-channel input terminal PT100 (RTD) for 2- or 3-wire connection	CTMT3102 CTMT3122 CTMT3162 CTMT3202	2 (differential) Inputs 2 (differential) Inputs 2 (single-ended) Inputs 2 Inputs, 2-/3 wire (default 3-wire) connection	180 180 180 190
Analog Output 2-channel analog output terminal 0...10 V, 16 bits 2-channel analog output terminal 4...20 mA, 16 bits 2-channel analog output terminal -10...+10 V, 16 bits	CTMT4102 CTMT4122 CTMT4132	2 (single ended) Outputs, 2-wire 2 (single ended) Outputs, 2-wire 2 (single ended) Outputs, 2-wire	210 190 210
Communication Serial interface 1 x RS232 Serial interface 1 x RS422/RS485 EtherCAT Profibus Master ¹ EtherCAT IO-Link Master ²	CTMT6001 CTMT6021 CTMT6731 CTMT6224		120 220 350 500
System Terminals End cap Potential supply, 24 VDC Potential supply, 24 VDC, with diagnostics Power supply terminals for E-bus	CTMT9011 CTMT9100 CTMT9110 CTMT9410	24V Input, to refresh E-bus	0 0 90 0
Encoder Terminals 1-channel encoder interface, differential inputs 1-channel encoder interface	CTMT5101 CTMT5151	Incremental encoder interface 5 V DC RS422 (TTL) Incremental encoder interface 24 V DC	130 130

NUM EtherCAT product identification

CTMx: Communication to machine
CTMG: Gateway
CTMT: Terminals

Important Remark

CTMT2602 and CTMT2612 requires a potential separation terminal

¹ Dedicated option required: FXSW282306

² Dedicated option required: FXSW282312



Ordering Code

NUM's EtherCAT terminals usually have an 8-digit identifier, which is printed on the device or attached to it on a sticker.

CTMx xxxx

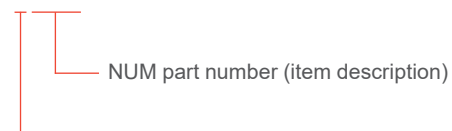

- G = Gateway
- T = Terminal
- P = Safe PLC
- S = Safe Terminal

Example

Example of EtherCAT Gateway Terminal **CTMG1100**

- **CTM** Structure of production
- **G** Gateway identification
- **1100** Part number

Please also refer to the previous page for more detailed information.

Technical Data

For detailed technical information about NUM's CTMG or CTMT EtherCAT terminals, please refer to reference manual M00032EN-00.

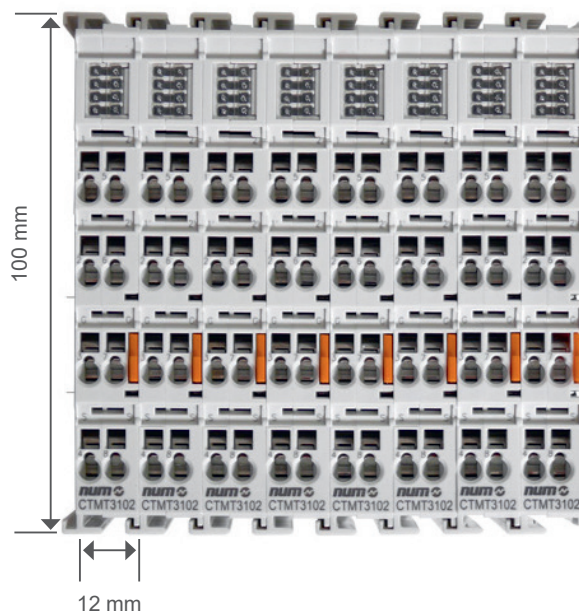

Note 1:

Nearly all types of CTMT terminals have the same dimensions.

Note 2:

NUM's CTMG and CTMT EtherCAT terminals are available from stock. For information about particular logic components, or to check their availability, please contact your local NUM sales office.



Main Accessories Overview

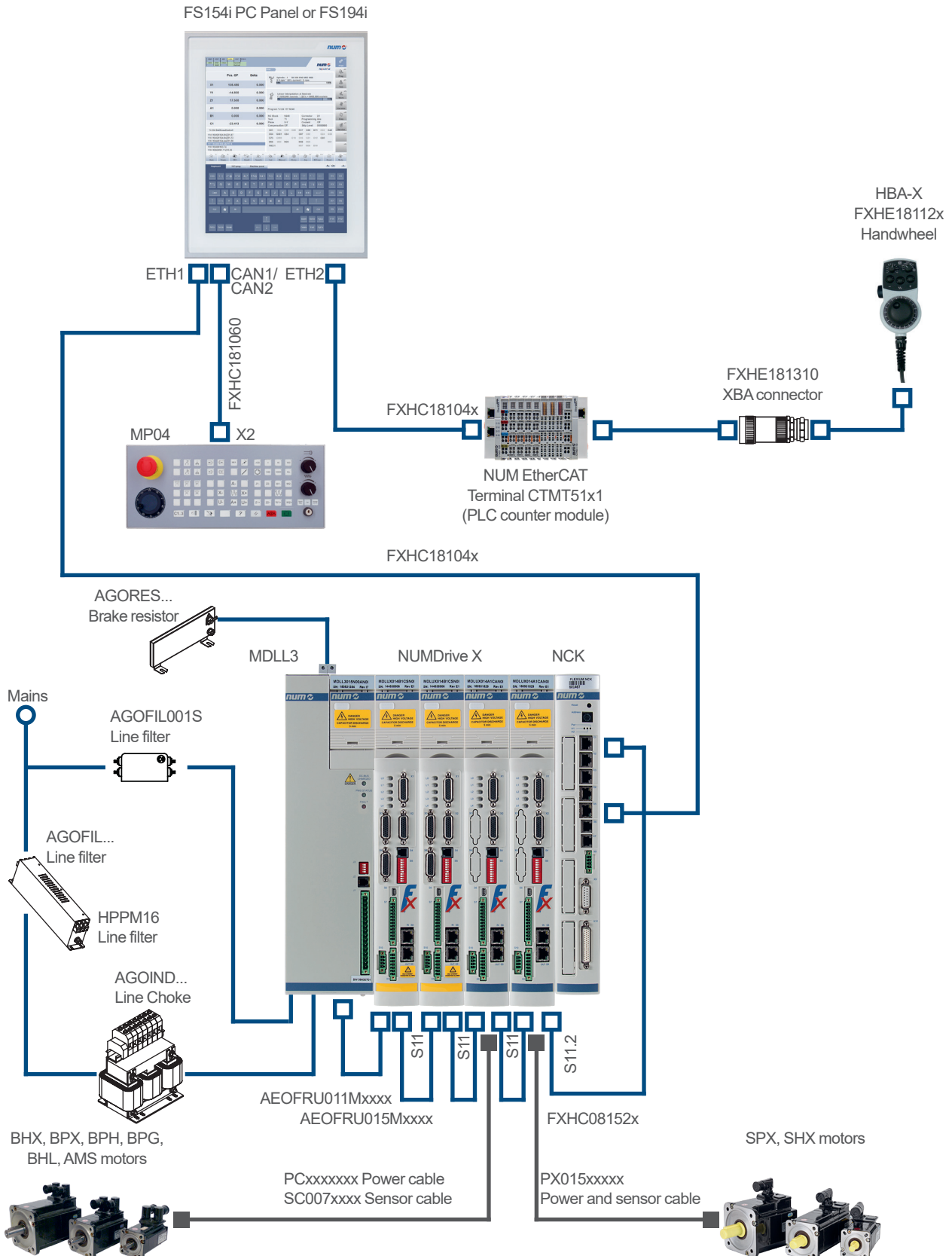

Multi-NCK Clock-Synchro Configuration

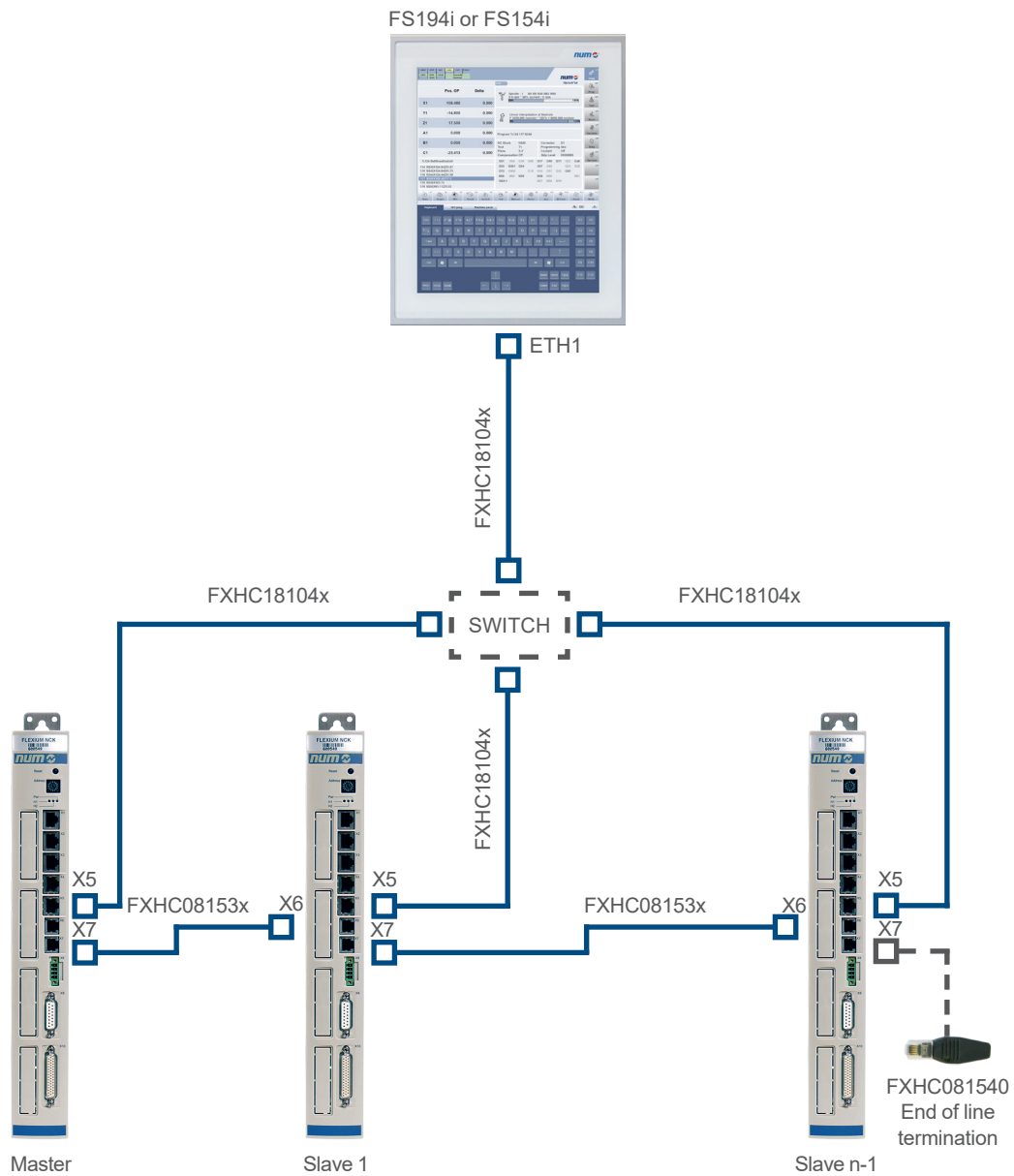

NUMDrive X with NUM-SAMX Module

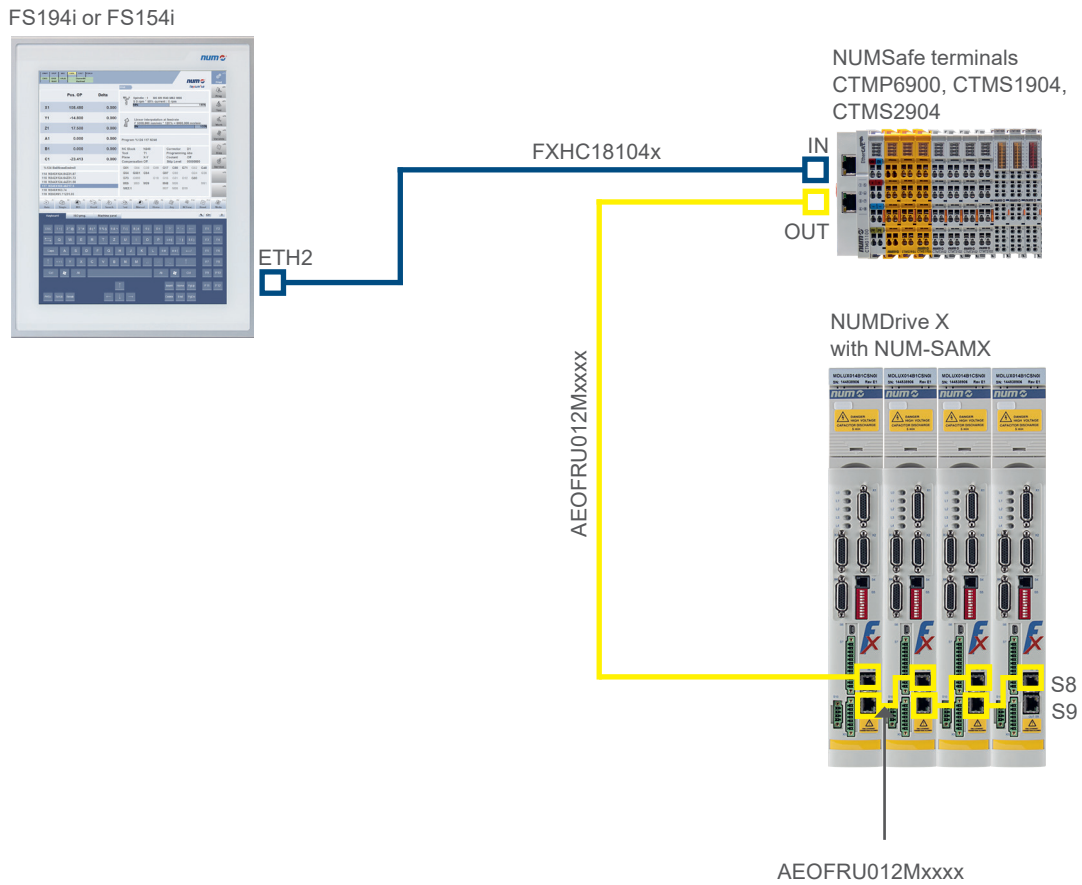



NUMDrive X with NUM-STOX Module

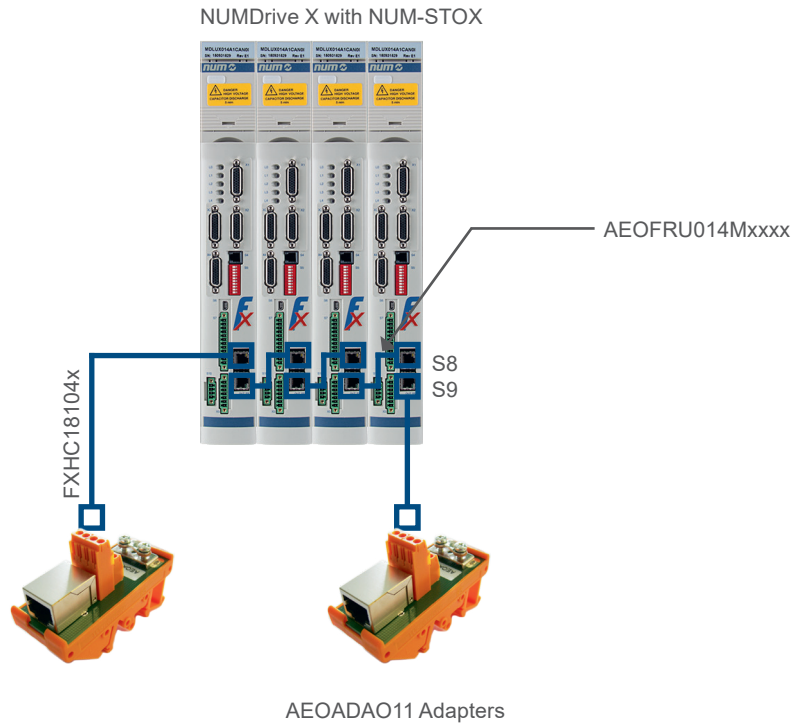

NUMDrive X with Tandem Application

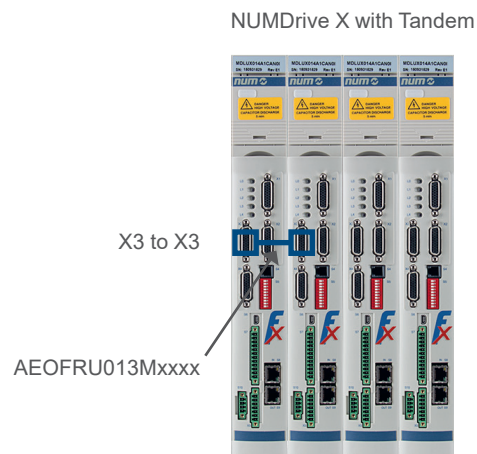

Mixed Configuration NUMDrive X with NUMDrive C CANopen Modules

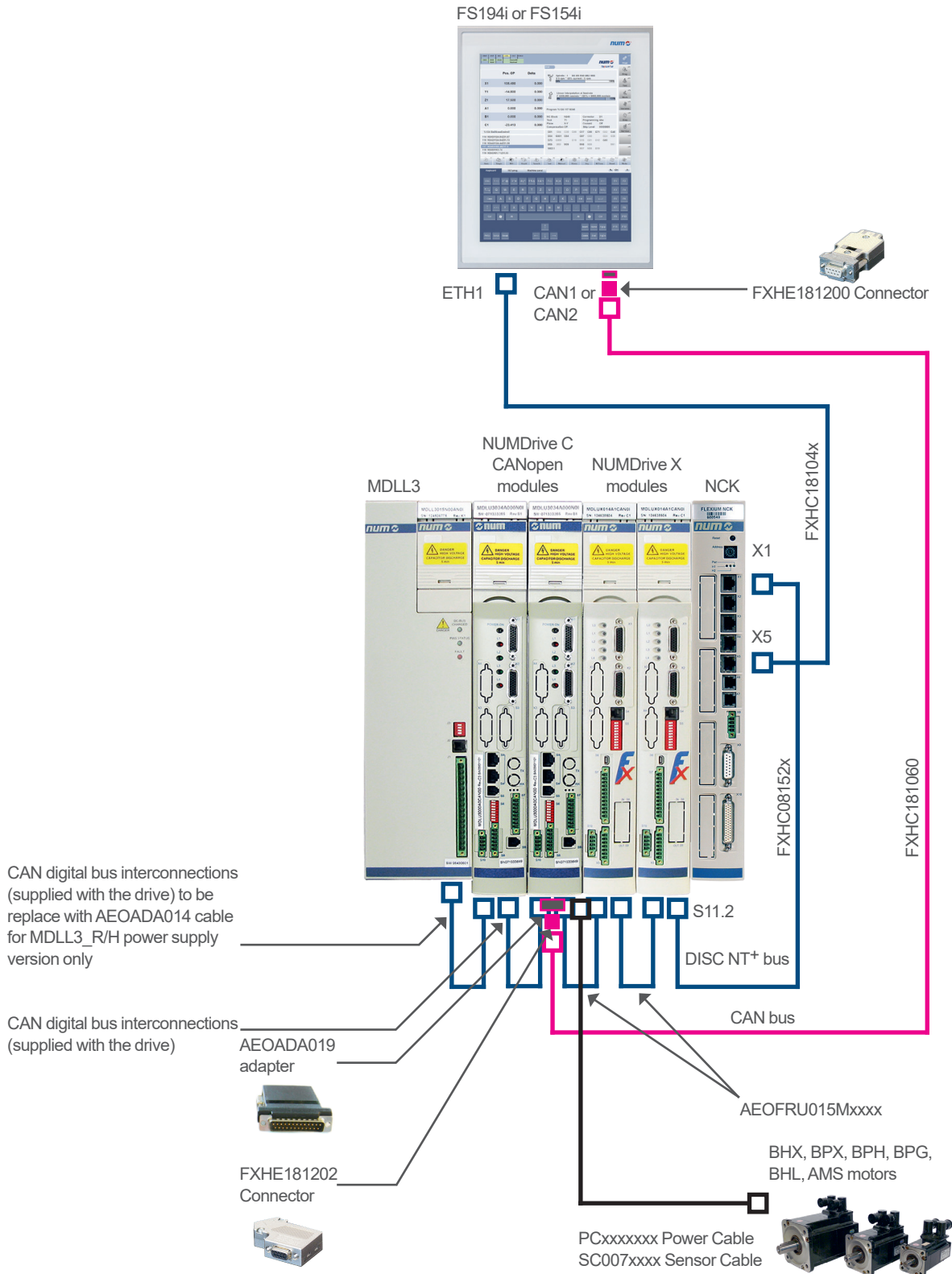



System Cables

Accessories	Order Code	Description	
NCK to NUMDrive X Cable	FXHC081520 FXHC081521 FXHC081522 FXHC081523 FXHC081524	0.6 m length 1 m length 2.5 m length 5 m length 10 m length	
NCK to FS154i or 192i Cable	FXHC181040 FXHC181041 FXHC181042 FXHC181043 FXHC181044 FXHC181045 FXHC181046	0.5 m length 1 m length 2 m length 5 m length 10 m length 20 m length 30 m length	
NCK Clock-Synchro Cable	FXHC081530 FXHC081531 FXHC081532	0.2 m length 2.5 m length 5 m length	
CAN Cable PVC, Purple, Shielded in Pairs	FXHC181060	Cable only. Required length must be specified in the order.	
End of Line Termination	FXHC081540	End terminal RJ45 for Multi-NCK. Clock-Synchro version	



System Cables

Accessories	Order Code	Description	
MDLL3 / MDLUX	AEOFRU011M0002 AEOFRU011M0003 AEOFRU011M0004	MDLUX size 1 - 2 MDLUX size 3 MDLUX size 4 - 6	
Cable for NUM-SAMX Connections (Yellow Cable RJ45)	AEOFRU012M0001 AEOFRU012M0002 AEOFRU012M00A2 AEOFRU012M0003 AEOFRU012M0004 AEOFRU012M0015 AEOFRU012M0020 AEOFRU012M0030	MDLUX size 1 MDLUX size 2 MDLUX size 3 MDLUX size 4 MDLUX size 6 Cable length 1.5 m Cable length 2 m Cable length 3m	
Cable for Tandem: • Anti-Backlash • Torque Duplication • Winding Duplication	AEOFRU013M0001 AEOFRU013M0002 AEOFRU013M00A2 AEOFRU013M0003 AEOFRU013M0004	MDLUX size 1 MDLUX size 2 MDLUX size 3 MDLUX size 4 MDLUX size 6	
Cable for NUM-STOX Connection (RJ45)	AEOFRU014M0001 AEOFRU014M0002 AEOFRU014M00A2 AEOFRU014M0003 AEOFRU014M0004	MDLUX size 1 MDLUX size 2 MDLUX size 3 MDLUX size 4 MDLUX size 6	
MDLUX DISC NT+ Cable for MDLUX Digital Bus Interconnections	AEOFRU015M0001 AEOFRU015M0002 AEOFRU015M00A2 AEOFRU015M0003 AEOFRU015M0004	MDLUX size 1 MDLUX size 2 MDLUX size 3 MDLUX size 4 MDLUX size 6	



System Connectors

Accessories	Order Code	Description	
Connector Kit for Flexium+: <ul style="list-style-type: none"> • X9 Analog I/Os • X10 Digital I/Os 	FXHE181301	X9 sub D 15 pin male connector X10 sub HD 44 pin male connector	
CAN Connector	FXHE181200	CAN female connector axial with integrated bus termination	
CAN Connector	FXHE181201	CAN female connector 90°	
CAN Connector	FXHE181202	CAN male/female connector 90° with prog. unit	



NUMSmartBackup

Accessories	Order Code	Description	
NUMSmartBackup 64GB	FXHE557102	The NUMSmartBackup system is a tool to backup or restore all Flexium iPCs	



NUMDrive X Connectors Kit

Accessories	Order Code	Description	
MDLUX Size 1 Power and Brake Connector	AEOCON018	<p>Suitable for: MDLUX007A1xxN0I MDLUX014A1xxN0I MDLUX021A1xxN0I MDLUX034A1xxN0I MDLUX007B1xxN0I MDLUX014B1xxN0I MDLUX021B1xxN0I</p> <p>Drive power connector with polarization key.</p>	
Drive Side Sensor Connector (X1, X2, X3, X4)	AEOCON012	<p>Suitable for all MDLUX</p> <p>Sensor connector Sub D HD 26 pin M. (4/40" screw thread connector).</p>	
MDLUX Size 2 and 3 Power and Brake Connector	AEOCON013	<p>Suitable for: MDLUX050A1xxN0I MDLUX075A1xxN0I MDLUX050B1xxN0I MDLUX100A1xxN0I MDLUX075B1xxN0I</p> <p>Drive power connector, brake connectors + fixing device, metallic strip and polarization keys.</p>	
MDLUX Size 3 Power and Brake Connector	AEOCON015	<p>Suitable for: MDLUX150A1xxN0I</p> <p>Drive power connector, brake connectors + fixing device, metallic strip and polarization keys.</p>	



NUMDrive X Adapters

Accessories	Order Code	Description	
RJ45 NUM-STOX Cable to Terminal Adapter	AEOADA011	NUM-STOX adapter with wire terminal connections (8 screw terminals)	
CAN BUS Adapter MDLUXMD-LU3	AEOADA019	1 Sub D 25 pin M 1 HDMI 1 Sub D 9 pin F	
CAN BUS Adapter MDLU3-MDLL3	AEOADA020	1 Sub D 25 pin M 1 Sub D 25 pin F 1 Sub D 9 pin F Cable length 20 cm	
MDLUX Dual Row Adapter	AEOADA021	1 Sub D 9 pin F 1 HDMI 2 RJ45	
MDLUX Dual Ring Adapter	AEOADA022	2 HDMI 1 RJ45	



MDLL3 Size 6 Power Supply Connection Kit

Accessories	Order Code	Description
MDLL3120N00AN01 MDLL3120N00RN01 MDLL3120N00HN01 Power Supply Connection Kit	AEOKIT003	Mandatory connection kit. See figure.

AEOKIT003



Metallic strip 50 mm for DC Bus



Self locking nut M8



Self locking nut M3



Eyebolt M8



Plug connector AUX



Metallic strip



16 pin connector



Plastic protection



Shell for 16 pin connector



Metallic plate for cable and shield fixing

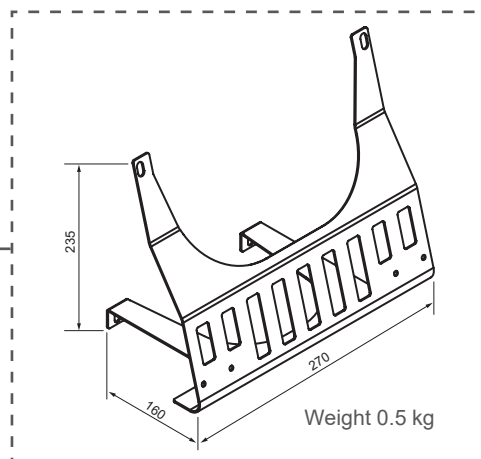



MDLUX Size 6 Drive Connection Kit

Accessories	Order Code	Description
MDLUX400A1xxN01 Drive Connection Kit	AEOKIT005	Mandatory connection kit. See figure.

AEOKIT005



Metallic strip 50 mm for DC Bus



Self locking nut M8



Self locking nut M3



Eyebolt M8



Plug connector AUX



Metallic strip



7 pin connector



Brace connector



Plastic protection



12 pin connector



Metallic plate for cable and shield fixing

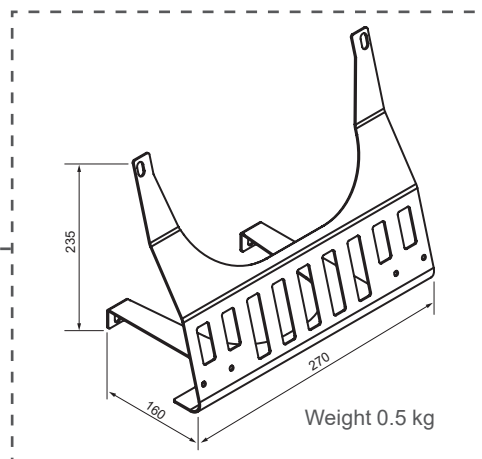



Fan Kit for NUMDrive X Size 6 AGOFAN001

Accessories	Order Code	Description
Fan Module	AGOFAN001	Mandatory for: MDLL3120N00HN0I MDLL3120N00AN0I MDLL3120N00RN0I MDLUX400A000N0I

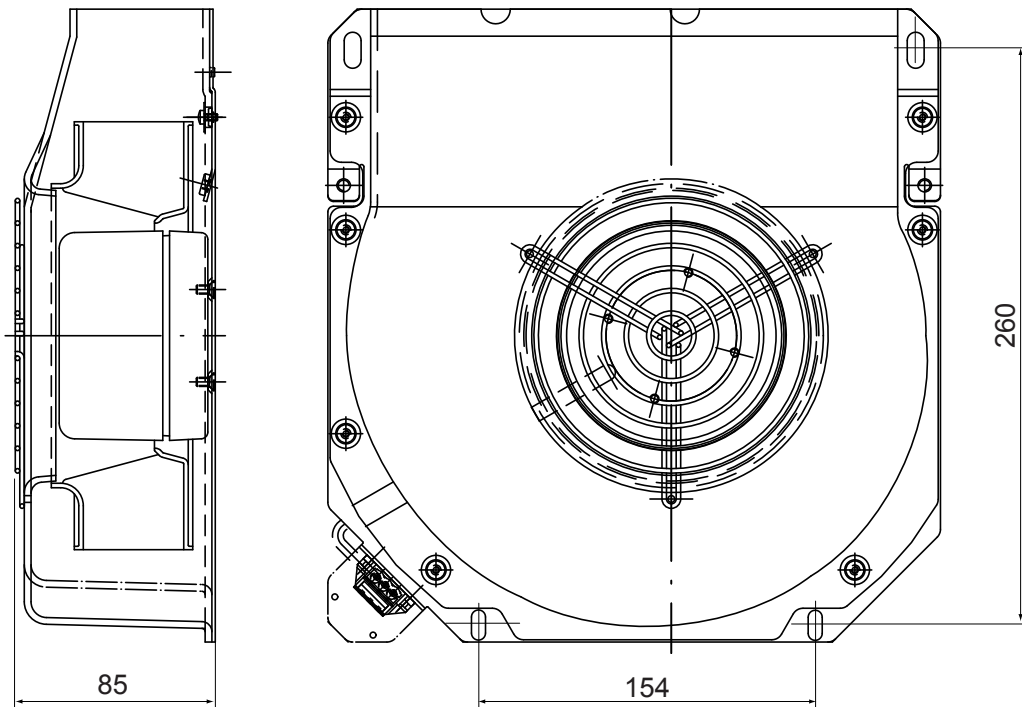



Socket for Portable Handwheel HBA-X FXHE181310

Accessories	Order Code	Description
Socket for Portable HBA-X	FXHE181310	XBA-X connector Please also refer to "Main accessories overview" section.

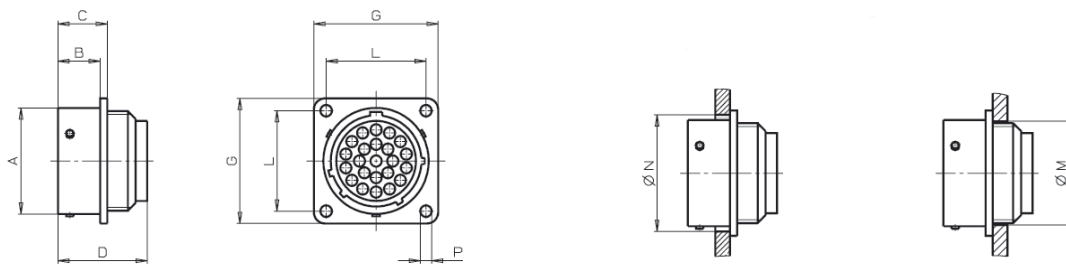
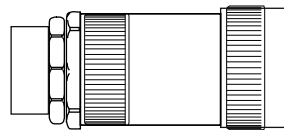



Overview Power Supply and Accessories

Power Supply MDLL	Line Filter 1	Line Filter 2: Auxillary Power Supply	Line Filter 3	Line Choke	Fan Module	Power Supply Connection Kit
MDLL3005M00AN0I	AGOFIL028	AGOFIL001S				
MDLL3015N00AN0I	AGOFIL024A	AGOFIL001S				
MDLL3025N00RN0I	AGOFIL026	AGOFIL001S	HPPM166	AGOIND006		
MDLL3025N00HN0I	AGOFIL026	AGOFIL001S	HPPM166	AGOIND001		
MDLL3030N00AN0I	AGOFIL025A	AGOFIL001S				
MDLL3050N00AN0I	AGOFIL026	AGOFIL001S		AGOIND007		
MDLL3050N00RN0I	AGOFIL026	AGOFIL001S	HPPM166	AGOIND007		
MDLL3050N00HN0I	AGOFIL026	AGOFIL001S	HPPM166	AGOIND002		
MDLL3120N00AN0I	AGOFIL027	AGOFIL001S		AGOIND008	AGOFAN001	AEOKIT003
MDLL3120N00RN0I	AGOFIL027	AGOFIL001S	HPPM166	AGOIND009	AGOFAN001	AEOKIT003
MDLL3120N00HN0I	AGOFIL027	AGOFIL001S	HPPM166	AGOIND009	AGOFAN001	AEOKIT003
MDLQ3001N00		AGOFIL001S				



Line Filter AGOFIL024A, 025A, 026, 027

Technical Data	AGOFIL024A	AGOFIL025A	AGOFIL026	AGOFIL027
MDLL3 Association	MDLL3015N00AN0I	MDLL3030N00AN0I	MDLL3025N00RN0I MDLL3025N00HN0I MDLL3050N00AN0I MDLL3050N00RN0I MDLL3050N00HN0I	MDLL3120N00AN0I MDLL3120N00RN0I MDLL3120N00HN0I
Rated Voltage	480 VAC 50/60 Hz			
Rated Current (refer. to 50°C amb. temp)	42 Arms	75 Arms	100 Arms	180 Arms
Test Voltage	3470 VDC, 2s (line to ground) 1700 VDC, 2s (line to line)			
Leakage Current	Normal condition < 3mA Fault condition 260mA (only one phase remaining)			
Standard	EN61800-3 category C3 - I <100mA (second environment (industrial low-voltage supply network))			
Terminal Block Cross Section: LINE/LOAD	10 mm ²	16 mm ²	50 mm ²	95 mm ²
Weight	2.8 kg	4.4 kg	4.7 kg	7.5 kg

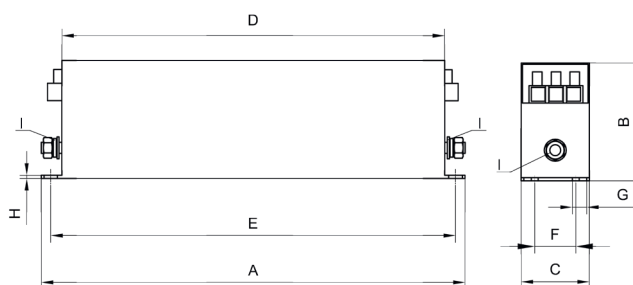

(I) Earth point connections (M6 or M10). Screw tightening torque: 1.9 - 2.1 Nm.

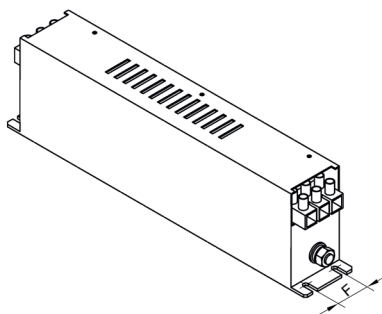

Line Filter	A	B	C	D	E	F	G	H	I
AGOFIL024A	310	85	50	280	395	30	5.4	2	M6
AGOFIL025A	270	135	80	240	255	60	6.5	3	M6
AGOFIL026	270	150	90	240	255	65	6.5	3	M10
AGOFIL027	380	170	120	350	362	102	6.5	3	M10

10



Line Filter AGOFIL028

Technical Data	AGOFIL028
MDLL3	MDLL3005M00AN01
Rated Voltage	250 VAC 50/60Hz
Rated Current (refer. to 40°C amb. temp)	20 A
Terminal Cross Section	Faston 6.3 x 0.8 mm
Weight	0.3 kg

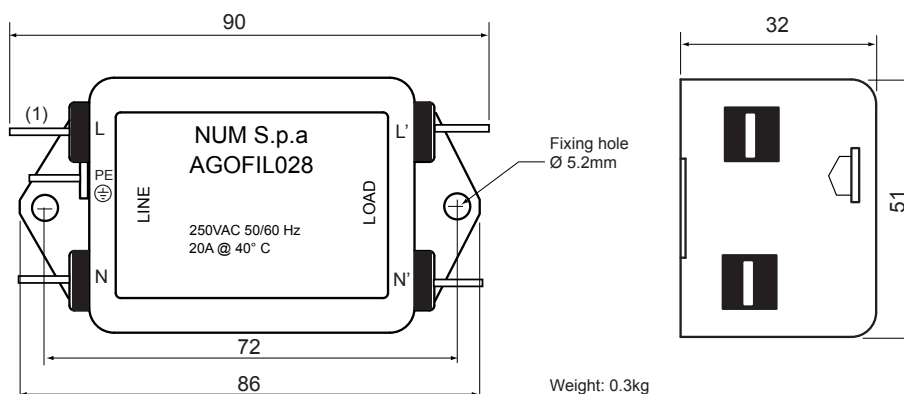

(1) Terminal cross section: Faston 6.3x0.8mm



Filter AGOFIL001S for Auxiliary Power Supply (mandatory for all power supplies)

Technical Data	AGOFIL001S
MDLL3, MDLQ Association	All MDLL3 and MDLQ power supply
Rated Voltage	480 VAC 50/60 Hz
Rated Current (refer. to 40°C amb. temp)	3 A
Leakage Current	0.5 mA
Terminal Cross Section	Faston 6.3 x 0.8 mm
Weight	0.3 kg

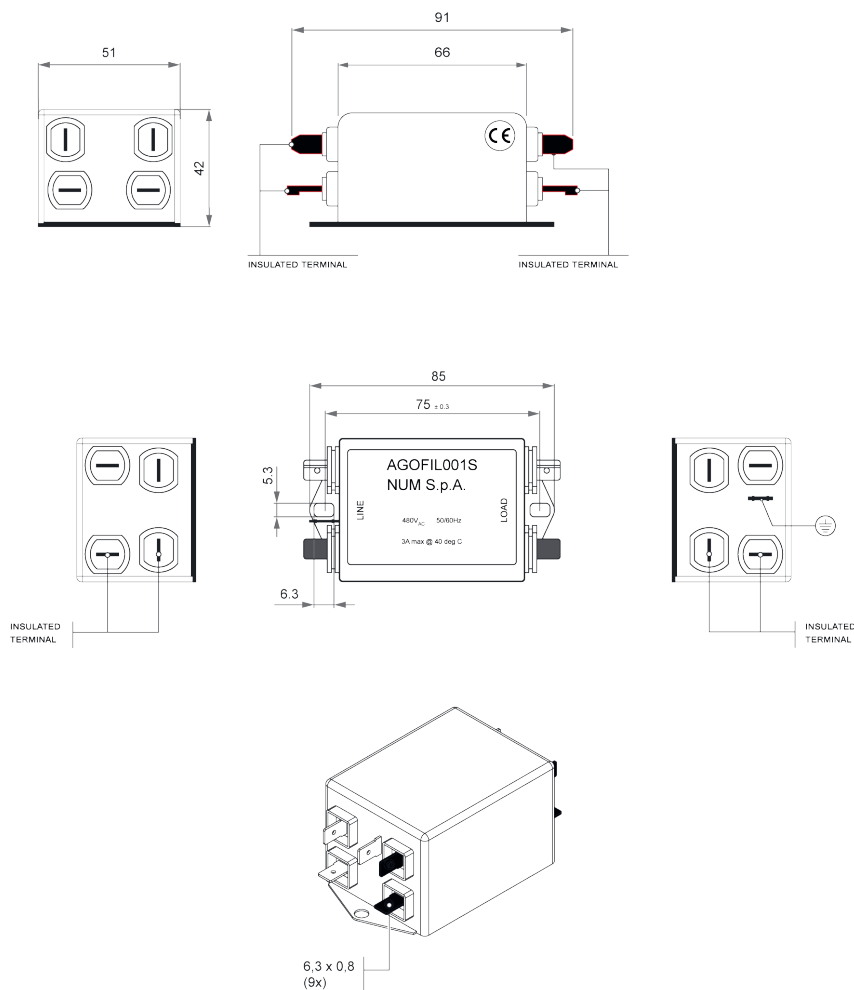

10



Line Filter HPPM166

Technical Data	HPPM166
MDLL3 Association	MDLL3025N00HNOI MDLL3050N00HNOI MDLL3025N00RNOI MDLL3050N00RNOI MDLL3120N00RNOI MDLL3120N00HNOI
Rated Voltage	440 VAC 50/60 Hz
Rated Current	20 A
Capacitance	3 x 16.6µF
Terminal Connections	M8 bolt
Weight	1.2 kg

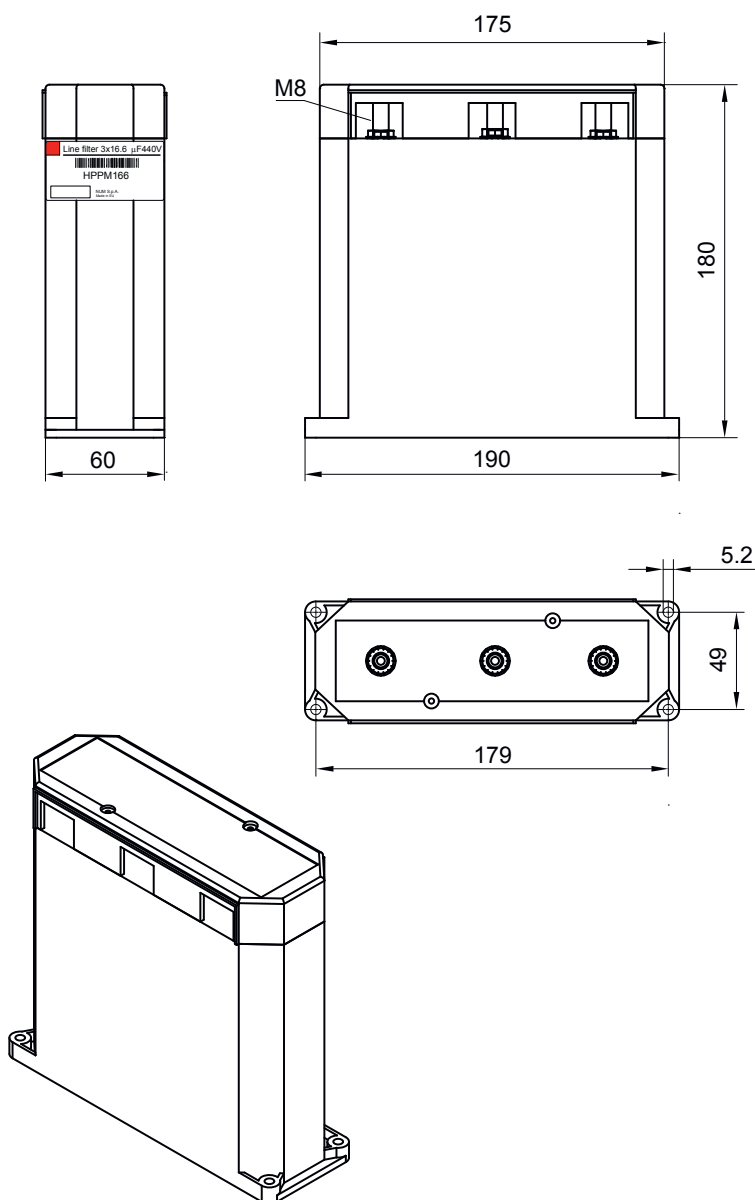



Line Chokes

Line Choke	AGOIND001	AGOIND002	AGOIND006	AGOIND007	AGOIND008	AGOIND009
MDLL3..... Association	...025N00HN0I	...050N00HN0I	...025N00RN0I	...050N00AN0I ...050N00RN0I	...120N00AN0I	...120N00HN0I ...120N00RN0I
Rated Voltage	67 Arms	103 Arms	60 Arms	100 Arms	230 Arms	210 Arms
Inductance	0.45 mH	0.27 mH	0.5 mH	0.3 mH	0.15 mH	0.15 mH
Losses	250 W	350 W	94 W	260 W	400 W	300 W
Degree of Protection	IP00					
Weight	13 kg	18 kg	11 kg	16 kg	45 kg	56 kg

AGOIND001 and AGOIND002 - Overall Dimensions

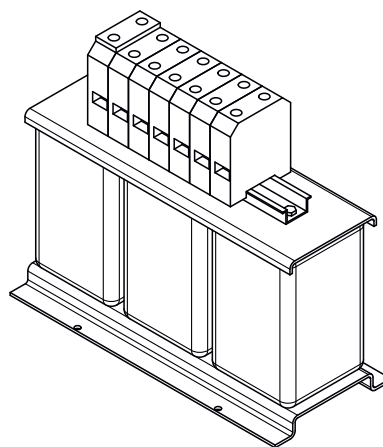
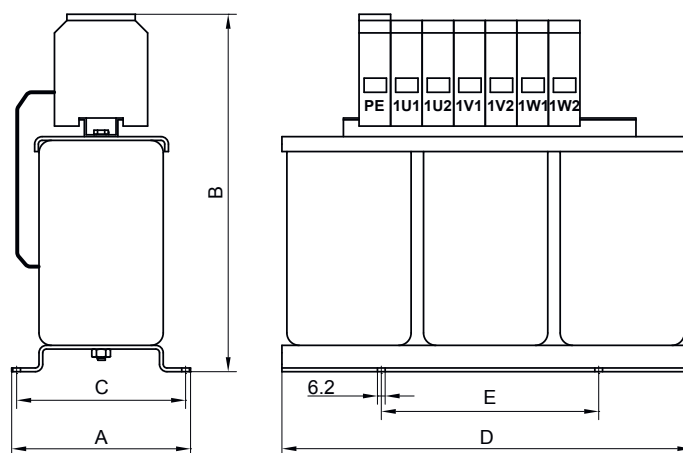

10

Line Choke	A	B	C	D	E	Terminal Block Cross Section
AGOIND001	150	230	136	330	175	35 mm ²
AGOIND002	150	280	136	330	175	50 mm ²



Line Chokes Overall Dimensions

AGOIND006 - Overall Dimensions

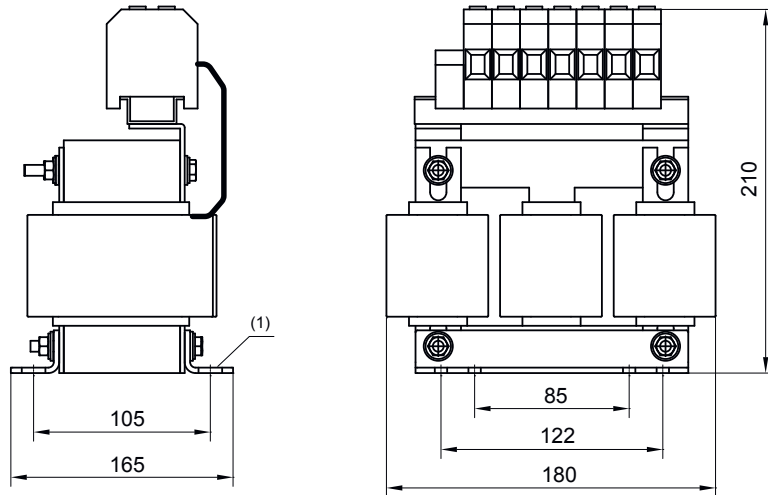

(1) 8x (Ø6x12)

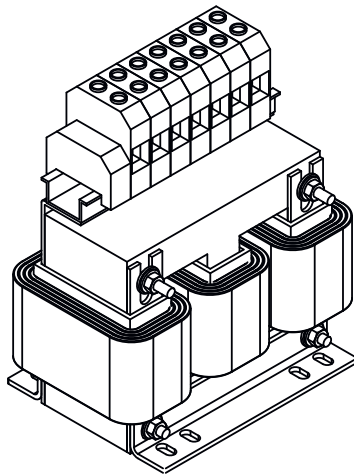



Line Chokes Overall Dimensions

AGOIND007 - Overall Dimensions

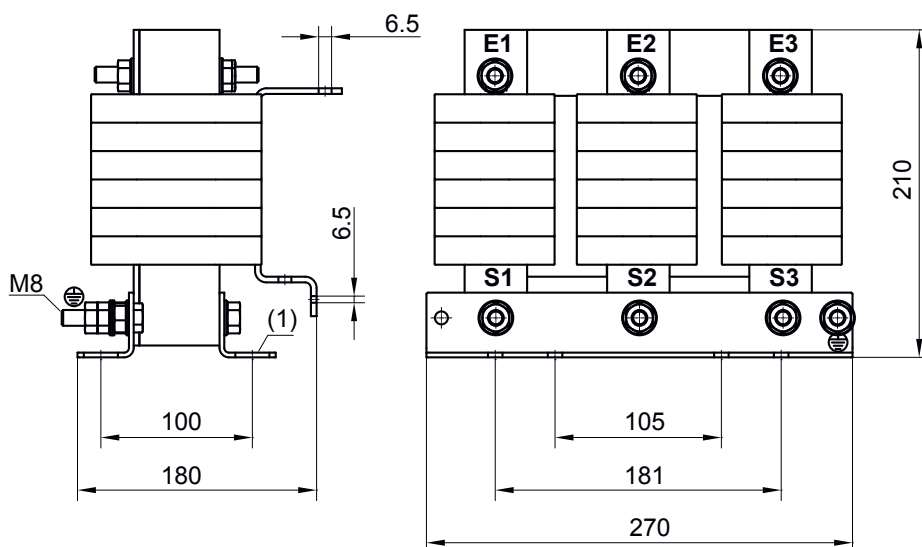

(1) 8x (Ø11x22)

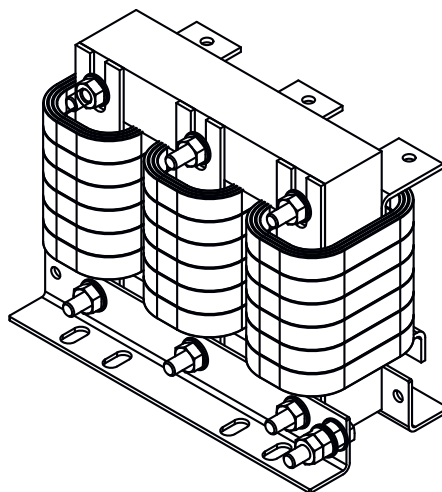



Line Chokes Overall Dimensions

AGOIND008 - Overall Dimensions

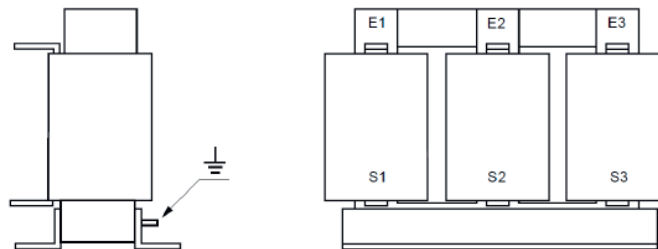
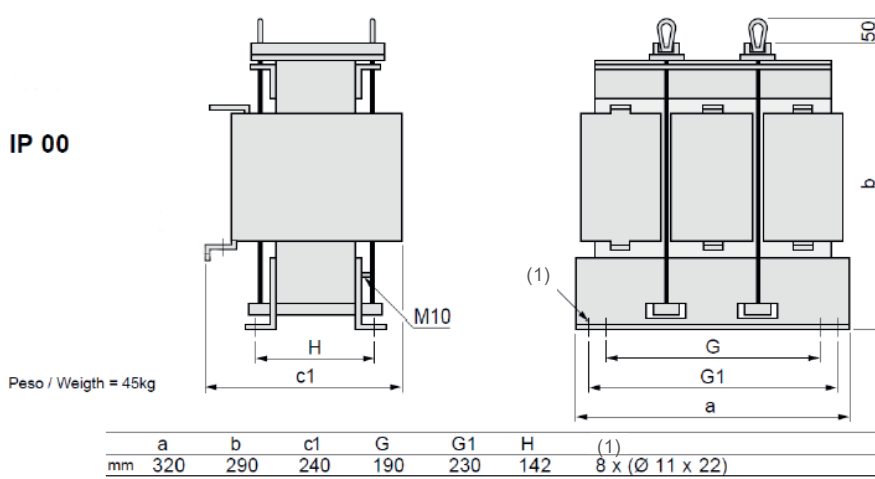



Line Chokes Overall Dimensions

AGOIND009 - Overall Dimensions

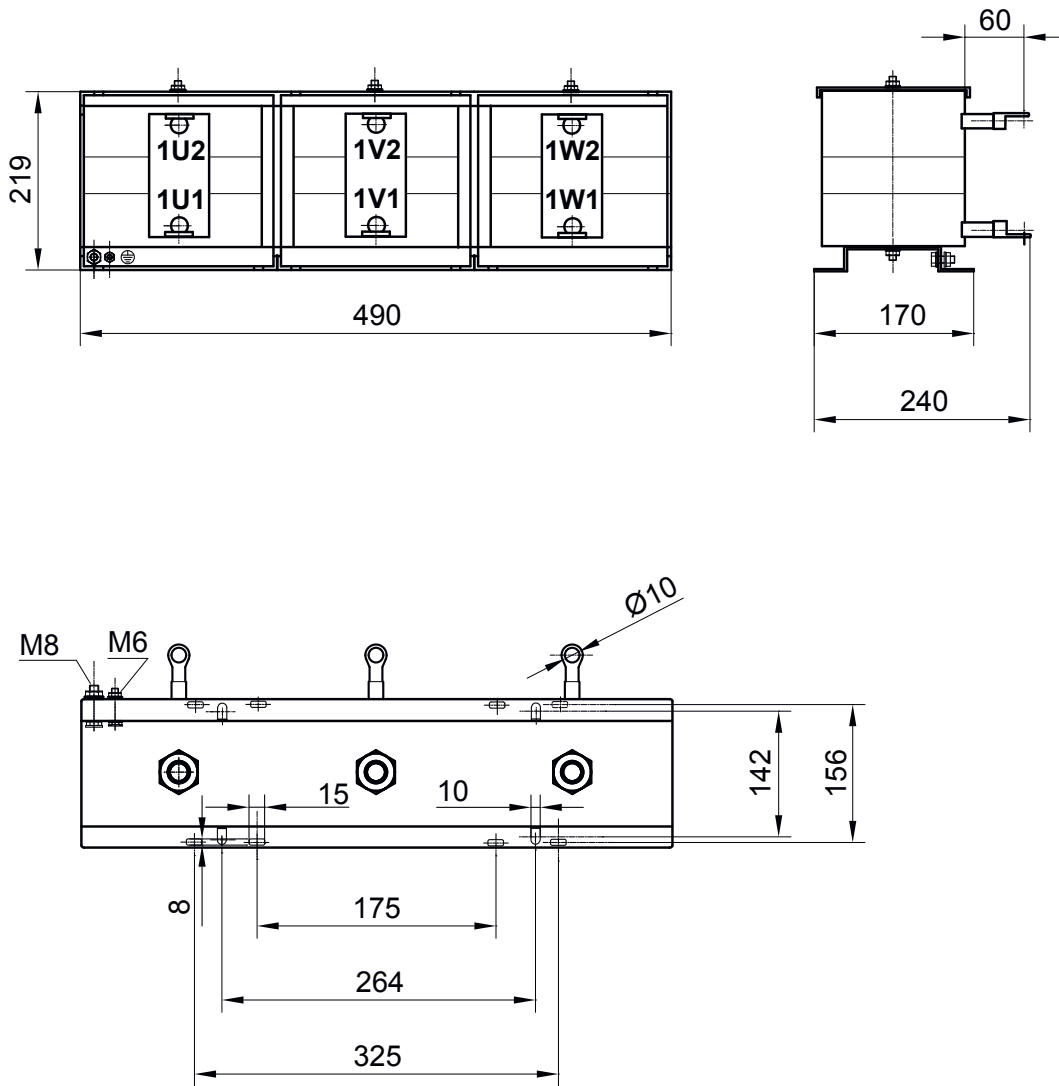







Braking Resistor

External Braking Resistor	AGORES008	AGORES009	AGORES010	AGORES011
Continuous Nominal Power (Environment Temperature 40°C)	480 W	480 W	2500 W	2500 W
Resistive Value	17 Ω	8.5 Ω	5.6 Ω	8.5 Ω
Resistor Thermal Protection by means of Thermal Switches	Thermal switch 1 fitted on the frame with N.C contact Contact interruption 10A/250 VAC Contact open >400°C for AGORES008/9 Contact open >160 °C for AGORES010/011			
Energy Pulse <500 ms	12 kJ	12 kJ	125 kJ	125 kJ
Weight	0.35 kg	0.35 kg	5.6 kg	5.6 kg

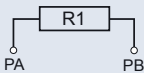
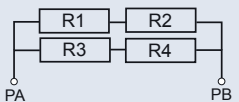
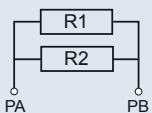

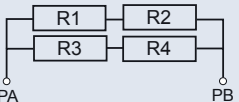
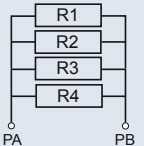
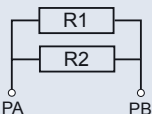
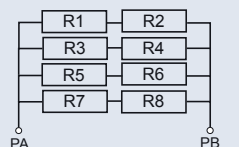

Braking Resistor Operating Examples

MDLL3 Association	Braking Resistor	Connection Configuration	Value [Ω]	P cont. [W]	Peak Power <100ms [kW]
MDLL3015N00AN01 MDLL3005M00AN01	AGORES008		17	480	30
	AGORES008 (X4)			1920	30
MDLL3030N00AN01 MDLL3025N00RN01 MDLL3025N00HN01	AGORES008 (X2)		8.5	960	61
	AGORES009			480	61
	AGORES009 (X4)			1920	61
MDLL3050N00RN01 MDLL3050N00HN01	AGORES008 (X4)		4.25	1920	120
	AGORES009 (X2) Basic Configuration			960	120
	AGORES009 (X8)			3840	120
	AGORES010			2500	100

10

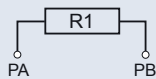
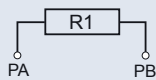
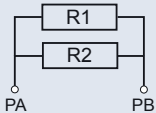
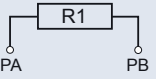
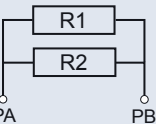
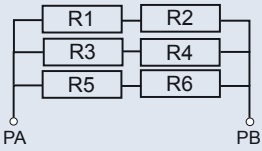
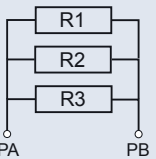

Braking Resistor Operating Examples

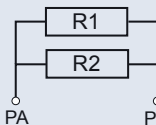
MDLL3 Association	Braking Resistor	Connection Configuration	Value [Ω]	P cont. [W]	Peak Power <100ms [kW]
MDLL3050N00AN01	AGORES010		5.6	2500	100
	AGORES011		8.5	2500	60
	AGORES011 (X2)		4.25	5000	120
MDLL3120N00HN01	AGORES010		5.6	2500	100 (Peak power <1s)
	AGORES010 (X2)		2.8	5000	200 (Peak power <1s)
MDLL3120N00AN01	AGORES010 (X6)		3.73	15000	120 (Peak power <2s)
	AGORES011 (X3)		2.8	7500	160 (Peak power <1s)
MDLL3120N00RN01	AGORES010		5.6	2500	100 (Peak power <1s)
	AGORES010 (X2)		2.8	5000	200 (Peak power <1s)



Braking Resistor Overall Dimensions

AGORES008, AGORES009 - Overall Dimensions

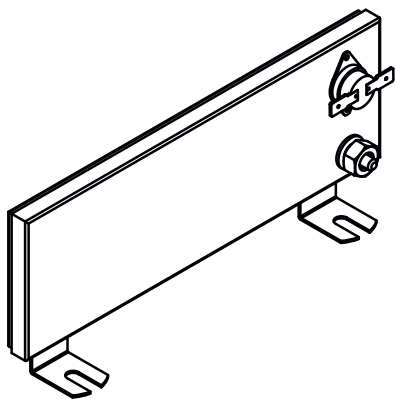
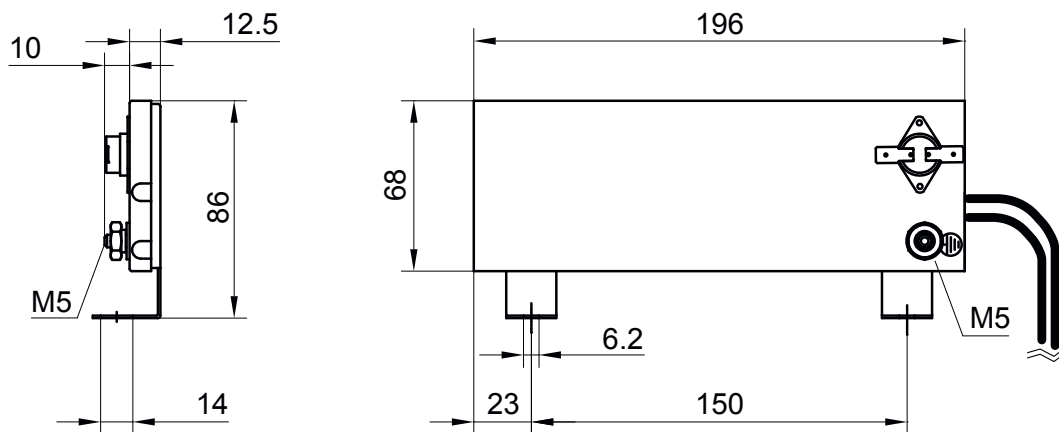

Braking Resistor Overall Dimensions

AGORES010, AGORES011 - Overall Dimensions

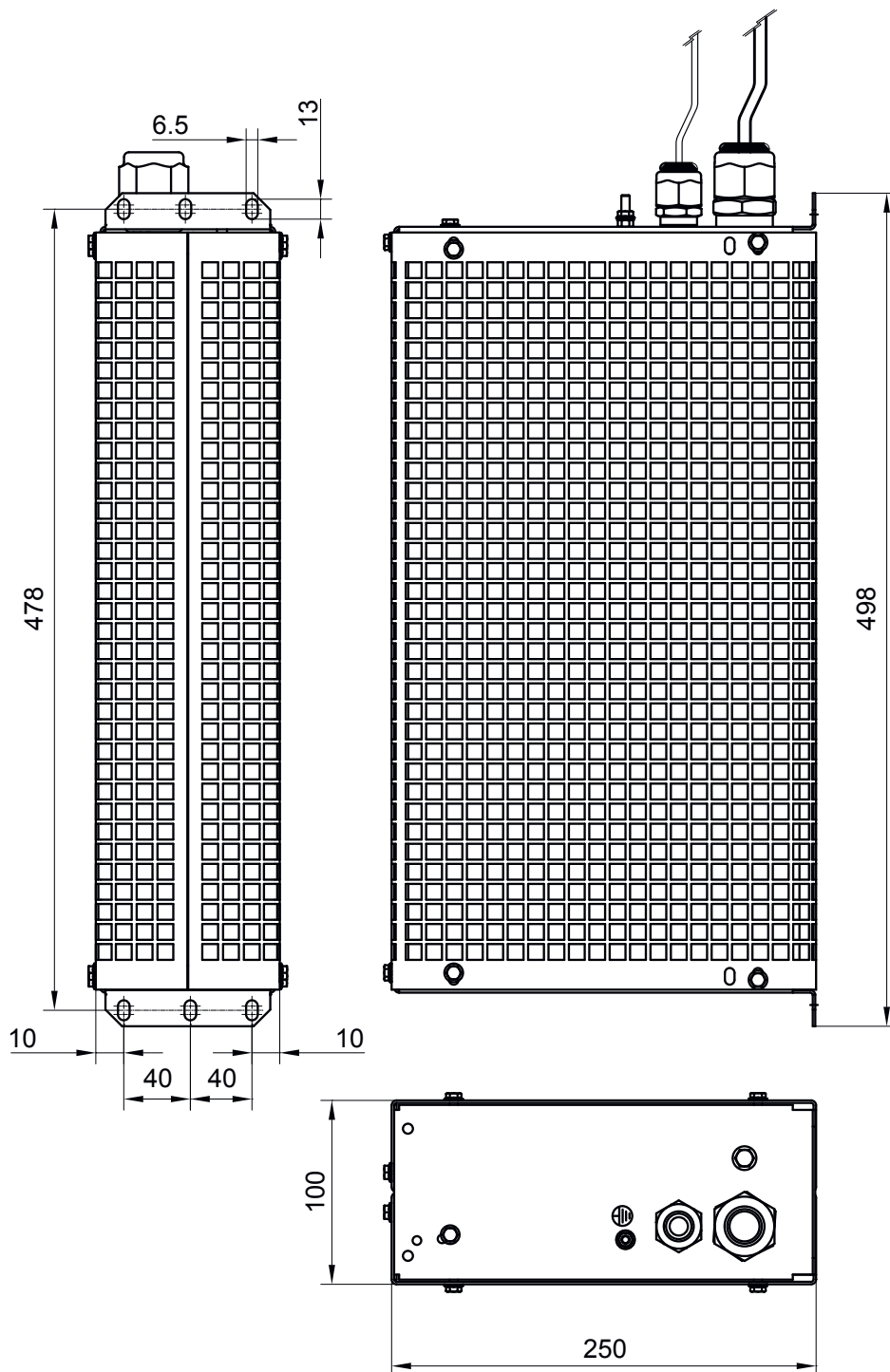

Vibration Detector (VDR)



Vibration Detector (VDR)

NUM vibration detector (accelerometer) can be directly connected to NUMDrive X and it's sampled at 100 microseconds; it can be used in for different applications:

- Cost effective solution for implementing an active damping close loop function (without the need of a machine sensor like linear scale).
- Dumping the tool center point vibrations
- Use the acceleration information to optimize the milling/turning process (avoid chattering for example)
- Detect and log machine crashes
- Estimate tool life and tool breakage even associated with NUMmonitor
- Detect spindle vibrations (bearing issues)
- Detect mechanical backlash
- Compensate cross-axes deformation

Technical Data	VDX1002A00AC000
Acceleration range	±2g
Direction of measurement	mono-axis, normal to mounting plane
Max measurable frequency	2 kHz
Output signal type	analogue (differential) 1 Vpp
Max output	60% of 1 Vpp at 2g
Power supply input	8+15V
Working temperature range	0-85 °C
Storage temperature range	0+100°C
Case material	aluminium
Weight	~55g
Mounting	2 screws M4x30 ISO4762 (DIN912)
Protection degree	IP67 (with plugged female connector)

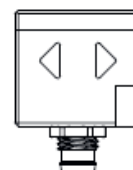
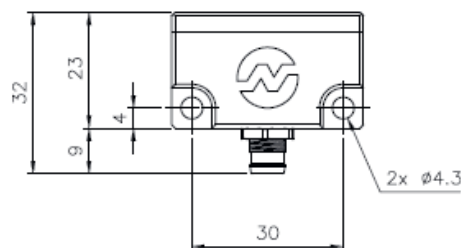
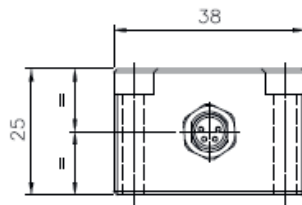



Auto-Transformer for BHL260 Fan (with 460V Network)

Technical Data	AMOTRAF001
Rated Power	500 VA
Input / Output Voltage	460 Vrms / 400 Vrms 3phases
Frequency	50/60 Hz
Protection Class as per EN60529	IP00
Weight	2.8 kg

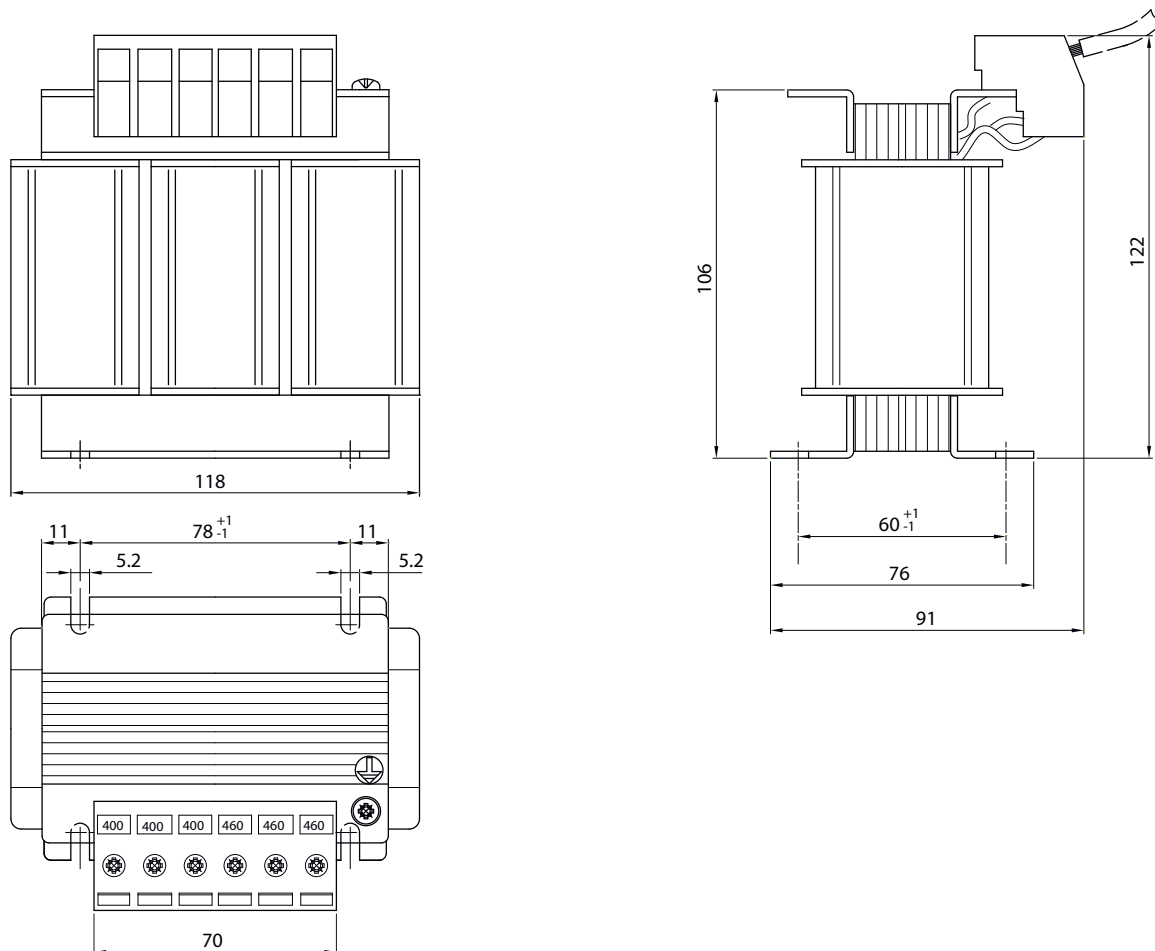



MDLC3010N00

Technical Data	MDLC3010N00
Rated input voltage	420 to 700 VDC
Module capacity	8250 μ F
Weight	6 kg



Motor Cables

The cables are available with different conductor sizes, characteristics and compositions. Options include High Performance and Basic Performance power cables, as well as combined power/sensor cables for use with SHX and SPX motors.

The cables comply with with UL and cUL recognized, DESINA and EC standards:

- Multi-strand conductors provide flexibility for movement
- The motor thermal probe is connected by the sensor motor cable
- The brake is connected by the power cable
- The connection between the power / sensor cable and the moving part of the connector must be made using the crimping tool

High Performance Power Cables

Cable Code	Brake Wires	Cable Composition	External Diameter (mm)
PC015BH00	Yes	(([3+T] x 1.5 mm ² + (2x1.5 mm ²))	11.8 ± 0.5
PC040BH00	Yes	(([3+T] x 4 mm ² + (2x1.5 mm ²))	14.4 ± 0.6
PC060BH00	Yes	(([3+T] x 6 mm ² + (2x1.5 mm ²))	16.3 ± 0.7
PC100BH00	Yes	(([3+T] x 10 mm ² + (2x1.5 mm ²))	19.2 ± 0.8
PC215BH00	Yes	(([3+T] x AWG04 + (2x1.5 mm ²))	24.7 ± 0.9
PC015NH00	No	(([3+T] x 1.5 mm ²)	10.6 ± 0.5
PC040NH00	No	(([3+T] x 4 mm ²)	13.2 ± 0.6
PC100NH00	No	(([3+T] x 10 mm ²)	18.1 ± 0.8

Operating Temperature	-30°C ... to + 80°C
Storage Temperature	-50°C ... to + 80°C
Nominal Voltage	Power: U ₀ /U = 0.6/1KV (VDE), U = 1000V (UL AWM/CSA AWM), Brake U = 24V (VDE)
Bending Radius (Dynamic)	≥ 7.5 x external diameter
Bending Radius (Static)	≥ 4 x external diameter
Maximum Speed	300 m/min
Maximum Acceleration	50 m/sec ²
Cycles	10.000.000
Torsion max	+/- 30°/m
Pulling Force (Dynamic)	≤ 20 N/mm ²
Pulling Force (Static)	≤ 50 N/mm ²
Capacitance [pF/m] Power • Conductor/Conductor • Conductor/Shield	sec. 1.5-2.5 mm ² <90 (Typical 80), sec. 4.0-6.0 mm ² <110 (Typical 90) <160 (Typical 130), <180 (Typical 140)
Capacitance [pF/m] Brake • Conductor/Conductor • Conductor/Shield	sec. 1.5 mm ² <120 (Typical 100) <200 (Typical 170)
Oil Resistant	HD 22.10 S2 (VDE 0282 p.10)//VDE 0472 p.803 B//EN 60811.2.1
Flame Resistant	EN 60332-1-1 // EN 60332-1-3 // FT1// UL 1581 sce.1061//EN 50265.2.1
UL/CSA LISTED, DESINA	Yes
Jacket Colour	PUR - Orange - RAL2003
Resistivity of Cable at 20°C [Ohm/km]	1.5 mm ² = 13.3, 4 mm ² = 4.95, 6 mm ² = 3.3, 10 mm ² = 1.91, 21 mm ² = 0.83
Max Useful Length	75 m



High Performance Power Cables for Single Cable Motor

Cable Code	Brake Wires	Cable Composition	External Diameter (mm)
PX007BH00	Yes	(3 x 0.75 mm ²) + T x 0.75 mm ² + (2x0.75 mm ²) + (2x AWG26)	12 ± 0.5
PX015BH00	Yes	(3 x 1.5 mm ²) + T x 1.5 mm ² + (2x1.5 mm ²) + (2x AWG22)	14.4 ± 0.5

Operating Temperature	-40°C ... to + 80°C
Storage Temperature	-40°C ... to + 80°C
Nominal Voltage	Power: U _o /U = 0.6/1KV (VDE) Brake U = 24V (VDE)
Bending Radius (Dynamic)	≥ 7.5 x external diameter
Bending Radius (Static)	≥ 5 x external diameter
Maximum Speed	300 m/min
Maximum Acceleration	50 m/sec ²
Cycles	5.000.000
Torsion max	+/- 30°/m
Pulling Force (Dynamic)	≤ 20 N/mm ²
Pulling Force (Static)	≤ 50 N/mm ²
Oil Resistant	UL 1581 – VDE 0472 part 803 A/B
Flame Resistant	CEI 20-35-1-2 – EN 50265-1-2 – IEC 60332-1-2 – UL VW-1 – CSA FT1
UL/CSA LISTED, DESINA	Yes
Jacket Colour	PUR - Orange - RAL2003
Resistivity of Cable at 20°C [Ohm/km]	AWG26 ≤ 131 , 0.75mm ² ≤ 39 AWG22 ≤ 59 , 1.50mm ² ≤ 13.3
Max Useful Length	(PX007) 20 m (PX015) 75 m



Basic Performance Power Cables

NUM Basic Performance cables are normally used where high flexibility is not strictly required.

Cable Code	Brake Wires	Cable Composition	External Diameter (mm)
PC015BL00	Yes	(([3+T] x 1.5 mm ² + (2x1.5 mm ²))	10.4 ± 0.4
PC040BL00	Yes	(([3+T] x 4 mm ² + (2x1.5 mm ²))	13 ± 0.5
PC015NL00	No	(([3+T] x 1.5 mm ²)	8.1 ± 0.4
PC040NL00	No	(([3+T] x 4 mm ²)	11.0 ± 0.5

Operating Temperature	-10°C ... to + 80°C
Storage Temperature	-20°C ... to + 80°C
Nominal Voltage	- Power : U _o /U = 0.6/1KV (VDE) - U = 1000 V (UL AWM/CSA AWM) - Brake U = 24 V (VDE)
Bending Radius (Dynamic)	≥ 15 x external diameter
Bending Radius (Static)	≥ 5 x external diameter
Maximum Speed	30 m/min
Maximum Acceleration	2 m/sec ²
Cycles	2.000.000
Torsion max	Not admitted
Pulling Force (Dynamic)	≤ 20 N/mm ²
Pulling Force (Static)	≤ 50 N/mm ²
Capacitance [pF/m] Power • Conductor/Conductor • Conductor/Shield	sec. 1.5-2.5 mm ² <90 (Typical 80), sec. 4.0-6.0 mm ² <110 (Typical 90) <160 (Typical 130), <180 (Typical 140)
Capacitance [pF/m] Brake • Conductor/Conductor • Conductor/Shield	sec. 1.5 mm ² <120 (Typical 100) <200 (Typical 170)
Oil Resistant	VDE 0472 p.803 B//EN 60811.2.1
Flame Resistant	EN 60332-1-1 // EN 60332-1-3 // FT1// UL 1581 sce.1061//EN 50265.2.1
UL/CSA LISTED, DESINA	Yes
Jacket Colour	Thermoplastic compound - Orange - RAL2003
Resistivity of Cable at 20°C [Ohm/km]	- 1.5 mm ² = 13.3, 4 mm ² = 4.95
Max Useful Length	75 m



Sensor Cable

Cable Code	Cable Composition	External Diameter (mm)
SC007SH00	(3x (2x 0.14 mm ²) + 4x 0.14 mm ² + 2x 0.50 mm ²)	9 ± 0.4mm
Operating Temperature	-20°C ... to + 60°C	
Storage Temperature	-50°C ... to + 60°C	
Nominal Voltage	UL AWM – CSA AWM U = 30 V	
Bending Radius (Dynamic)	≥ 10.5 x external diameter	
Bending Radius (Static)	≥ 7 x internal diameter	
Maximum Speed	220 m/min	
Maximum Acceleration	10 m/sec ²	
Cycles	10.000.000	
Torsion max	+/- 30°/m	
Pulling Force (Dynamic)	≤ 50 N/mm ²	
Pulling Force (Static)	≤ 120 N/mm ²	
Oil Resistant	VDE 0282 p.10 HD 22.10 S1	
Flame Resistant	EN 60332-1 - EN 50265-2-1	
UL/CSA LISTED, DESINA	Yes	
Jacket Colour	Green - RAL6018	
Resistivity of Cable at 20°C [Ohm/km]	0.14mm ² ≤ 149 Ohm/km 0.50mm ² ≤ 41 Ohm/km	
Max Useful Length	75 m	

Fan Cable for BHL and AMS Motors

Cable Code	Cable Composition	External Diameter (mm)
NC010NL00	([3+T] x1,5 mm ² (not shielded))	8 ± 0.2



Raw Cable Ordering Codes

Raw Power Cable Ordering Code ¹

	PC	015	B	H	0	0
Cable Type						
• Power Cable						
Cable Section						
• Cable Section 1.5 mm ²		015				
• Cable Section 4 mm ²		040				
• Cable Section 6 mm ²		060				
• Cable Section 10 mm ²		100				
• Cable Section 21.5 mm ²		215				
Brake						
• With Brake			B			
• Without Brake			N			
Application						
• High Performance				H		
• Basic Performance				L		
Cable Alone						
• Fixed Value					0	0

Raw Power Cable Ordering Code ¹

	SC	007	S	H	0	0
Cable Type						
• Sensor Cable						
Identification Number		007				
Variant			S			
Application						
• High Performance				H		
Cable Alone						
• Fixed Value					0	0

¹ Note: the required length of raw cable (max 75 m) is specified as 'quantity' in the order.



Raw Cable Ordering Codes

Raw Power / Sensor Cable Ordering Code ¹

	PX	015	B	H	0	0
Cable Type						
• Power and signal cable (for SHX, SPX motors)						
Cable section						
• Power cable section 0.75 mm ²		007				
• Power cable section 1.5 mm ²		015				
Brake						
• With brake			B			
Application						
• High Performance				H		
Cable Alone						
• Fixed Value					0	0

Raw Power Cable Ordering Code ¹

	NC	010	N	L	0	0
Cable Type						
• Others Cable						
Identification Number						
		010				
Variant						
			N			
Application						
• Basic Performance				L		
Cable Alone						
• Fixed Value					0	0

10

¹ Note: the required length of raw cable (max 20 m for PX007, max 75 m for PX015 and NC010) is specified as 'quantity' in the order.

Ordering Raw Cable - Example

Cable Code Example	Raw Cable Length Definition
PC015BH00 „Quantity“ 50 m Raw Cable Length Definition	The raw cable length is defined as 'quantity' in the order. In this case the raw power + brake cable length is 50 m.



Power Assembly Cable Ordering Code

	PC	015	B	H	0	0	M	000	0
Cable Type									
• Power Cable									
Cable Section									
• Cable Section 1.5 mm ²		015							
• Cable Section 4 mm ²		040							
• Cable Section 10 mm ²		100							
Brake									
• With Brake			B						
• Without Brake			N						
Application									
• High Performance				H					
• Basic Performance				L					
Motor Connector									
• Without connector					0				
• AMOCON004D					4				
• AMOCON005D					5				
Drive Connector									
• Without connector						0			
• AEOCON018						1			
• AEOCON013						2			
• AEOCON015						5			
Cable Assembly									
Cable Length									
• Meter (m)									
Cable Length									
• 0.1 meter (dm)									

Note:

- The max cable length is 75 m
- Not all combinations of cable/connector couplings are possible



Power and brake cable



Sensor Assembly Cable Ordering Code

	SC	007	S	H	0	0	M	000	0
Cable Type									
• Sensor Cable									
Identification number		007							
Variant			S						
Application									
• High Performance				H					
Motor Connector									
• Without connector						0			
• CONN125D00						1			
• AMOCON002D						2			
Drive Connector									
• Without connector							0		
• AEOCON012							4		
Cable Assembly									
Cable Length									
• Meter (m)									
Cable Length									
• 0.1 meter (dm)									

Note:

- The max cable length is 75 m
- Not all combinations of cable/connector couplings are possible



Sensor cable



Single Motor Cable Assembly (for SHX and SPX Motors) Ordering Code

	PX	007	B	H	6	0	M	000	0
Cable Type									
• Power and signal cable (for SHX, SPX motors)									
Cable Section									
• Power cable section 0.75 mm ²									
• Power cable section 1.5 mm ²									
Brake									
• With brake									
Application									
• High Performance									
Motor Connector									
• Without connector									
• AMOCON006D									
Drive Connector									
• Without connector									
• AEOCON018									
• AEOCON013									
Cable Assembly									
Cable Length									
• Meter (m)									
Cable Length									
• 0.1 meter (dm)									

Note:

- The max cable length is: 20m for PX007 and 75m for PX015
- Not all combinations of cable/connector couplings are possible
- Whenever the drive connector is not required add 50 cm of cable for the encoder connections



Encoder cable (power/sensor)



Fan Assembly Cable (for AMS, BHL Motors) Ordering Code

	NC	010	N	L	7	0	M	000	0
Cable Type • Fan Cable									
Identification number		010							
Variant			N						
Application • Basic Performance				L					
Motor Connector • CONN113D00					7				
Drive Connector • Without connector						0			
Cable Assembly									
Cable Length • Meter (m)									
Cable Length • 0.1 meter (dm)									



Fan cable



BHX and BPX Connectors, Cables and Cable Assemblies

BHX / BPX	Connectors		Cable		Cable Assemblies ¹	
	Power	Sensor	Power	Sensor	Power	Sensor
0551V5... ²	AMOCON004D	AMOCON002D	PC015xy00	SC007SH00	PC015xy4zMnnnn	SC007SH2wMnnnn
0751V5...						
0752V5...						
0951V5...						
0952N5...						
0952V5...						
1261N5...						
1261V5...						
1262N5...						
1262V5...						
1263N5...						
1263R5...						
1552N5...						
1552R5...						
1554N5...						

¹ Note for the cable assemblies:

x: cable with or without brake wires
 x = B for cable with brake wires
 x = N for cable without brake wires

y: cable performance
 y = H for High performance cable
 y = L for Basic performance cable

z: power connector on drive side
 z = 0 without connector
 z = 1 with connector AEOCON018
 z = 2 with connector AEOCON013

w: sensor connector on drive side
 w = 0 without connector
 w = 4 with connector AEOCON012

n n n n = cable length in 0.1 m
 n n n n = 0105 = 10.5 m

² Available as BPX only



SHX and SPX Connectors, Cables and Cable Assemblies

SHX / SPX	Motor Connector	Cable	Cable Assemblies ¹
0751V5...	AMOCON006D	PX007BH00 or PX015BH00	PX007BH6yMnnnn or PX015BH6zMnnnn
0752V5...			
0951V5...			
0952N5...			
0952V5...			
1261N5...			
1261V5...		PX015BH00	PX015BH6zMnnnn
1262N5...			
1262V5...			
1263R5...		PX007BH00 or PX015BH00	PX007BH6yMnnnn or PX015BH6zMnnnn
1552N5...			
1552R5...			
1554N5...			

¹ Note for the cable assemblies:

y: power connector on drive side
y = 0 without connector
y = 1 with connector AEOCON018

z: power connector on drive side
z = 0 without connector
z = 1 with connector AEOCON018
z = 2 with connector AEOCON013

n timer = cable length in 0.1 m
n timer = 0105 = 10.5 m



BPH Connectors, Cables and Cable Assemblies

BPH	Connectors		Cable		Cable Assemblies ¹	
	Power	Sensor	Power	Sensor	Power	Sensor
0751N5...	AMOCON004D		PC015xy00		PC015xy4zMnnnn	
0751V5...						
0752N5...						
0752V5...						
0754N5...						
0952N5...						
0952V5...						
0953N5...						
0953V5...						
0955N5...						
1152N5...						
1152V5...						
1153K5...						
1153N5...						
1153V5...						
1154K5...						
1154N5...						
1154V5...						
1156N5...						
1422K5...			AMOCON002D			
1422N5...						
1422R5...	PC015xy00	PC015xy4zMnnnn				
1423K5...						
1423N5...	PC040xy00	PC040xy4zMnnnn				
1423R5...						
1424K5...	PC015xy00	PC015xy4zMnnnn				
1424N5...						
1424R5...	PC040xy00	PC040xy4zMnnnn				
1427N5...						
1902K5...	AMOCON005D		PC100xy00		PC100xy5zMnnnn	
1902N5...						
1902R5...			PC040xy00		PC040xy4zMnnnn	
1903K5...						
1903N5...			PC100xy00		PC100xy5zMnnnn	
1904K5...						
1904N5...			PC040xy00		PC040xy4zMnnnn	
1904N5...						
1904N5...			PC100xy00		PC100xy5zMnnnn	
1905H5...						
1905H5...	PC040xy00	PC040xy4zMnnnn				
1905L5...						
1907K5...	AMOCON005D		PC100xy00	PC100xy5zMnnnn		
1907N5...						
190AK5...						

¹ See page 291 for cable assembly notes



BPG Connectors, Cables and Cable Assemblies

BPG	Connectors		Cable		Cable Assemblies 1	
	Power	Sensor	Power	Sensor	Power	Sensor
0751N5...	AMOCON004D	AMOCON002D	PC015Ny00	SC007SH00	PC015Ny4zMnnnn	SC007SH2wMnnnn
0752N5...						
0952N5...						
0953N5...						
1152N5...						
1153K5...						
1153N5...						
1153V5...						
1422N5...						
1423N5...						
1424K5...						
1424R5...						
1427N5...						
1902K5...						
1902N5...						
1903K5...	AMOCON005D		PC100Ny00		PC100Ny5zMnnnn	
1903N5...						
1904N5...						
1905L5...						

¹ Note for the cable assemblies:

x: cable with or without brake wires
 x = B for cable with brake wires
 x = N for cable without brake wires

y: cable performance
 y = H for High performance cable
 y = L for Basic performance cable

z: power connector on drive side
 z = 0 without connector
 z = 1 with connector AEOCON018
 z = 2 with connector AEOCON013
 z = 5 with connector AEOCON015

w: sensor connector on drive side
 w = 0 without connector
 w = 4 with connector AEOCON012

n n n n = cable length in 0.1 m
 n n n n = 0105 = 10.5 m



BHL Connectors, Cables and Cable Assemblies

BHL	Connectors			Cables		
	Power	Sensor	Fan	Power	Sensor	Fan
2601N5...	AMOCON005D	AMOCON002D	CONN113D00	PC100xH00	SC007SH00	NC010NL00
2601N1...	None			PC215BH00		
2602K5...	AMOCON005D			PC100xH00		
2602K1...	None			PC215BH00		

BHL	Cable Assemblies ¹			High-Strength Cable Gland
	Power	Sensor	Fan	
2601N5...	PC100xH50Mnnnn	SC007SH2wMnnnn	NC010NL70Mnnnn	None
2601N1...	PC215BH00			BMHQPRE3
2602K5...	PC100xH50Mnnnn			None
2602K1...	PC215BH00			BMHQPRE3

¹ Note for the cable assemblies:

x: cable with or without brake wires
 x = B for cable with brake wires
 x = N for cable without brake wires

w : sensor connector on drive side
 w = 0 without connector
 w = 4 with connector AEOCON012

nnnn = cable length in 0.1 m
 nnnn = 0105 = 10.5 m



AMS and IM18 Connectors, Cables and Cable Assemblies

AMS	Connectors		High-Strength Cable Gland	Cable			Cable Assemblies ¹												
	Sensor	Fan		Power	Sensor	Fan	Sensor	Fan ²											
100SB1...	CONN125D00	CONN113D00	BMHQPRE2	PC060BH00	SC007SH00	NC010NL00	SC007S-H1wMnnnn	NC010N-L70Mnnnn											
100MB1...																			
100GB1...																			
100SD1...																			
100MD1...																			
100GD1...																			
132SA1...									BMHQPRE3	PC100BH00									
132SC1...											PC215BH00								
132SE1...												PC100BH00							
132MA1...													PC215BH00						
132MC1...														PC100BH00					
132ME1...															PC215BH00				
132LA1...																PC100BH00			
132LE1...			PC215BH00																
132SF1...				PC100BH00															
132SG1...																	PC215BH00		
132SH1...																		PC100BH00	
132MF1...																			PC215BH00
132MG1...																			
132MH1...									PC215BH00										
132LF1...										PC100BH00									
132LI1...											PC215BH00								
132LH1...												PC100BH00							
160MA1...													2 x BMHQPRE3	2 x PC215BH00					
160MB1...																			
160MC1...																			
160LA1...																			
160LB1...																			
160LC1...																			

10



IM	Connectors		High-Strength Cable Gland	Cable			Cable Assemblies ¹	
	Sensor	Fan		Power	Sensor	Fan	Sensor	Fan ²
18MK14...	AMO-CON002D	CONN114D00	2 x M50	2 x (4x25 mm ²)	SC007SH00	2x1 mm ²	SC007S-H2wMnnnn	-

¹ Note for the cable assemblies:
w: sensor connector on drive side
w = 0 without connector
w = 4 with connector AEOCON012
nnnn = cable length in 0.1 m
nnnn = 0105 = 10.5 m

² Only the motor connector is present and assembled



Motor Connectors Description

Accessories	Order Code	Description	
Motor Sensor Connector	AMOC0N002D	17 pole connector	
Motor Power Connector	AMOC0N004D	6 pole connector	
Motor Power Connector	AMOC0N005D	6 pole connector	
Motor Power / Encoder Connector	AMOC0N006D	9 pole connector	
Motor Fan Connector	CONN113D00	5 pole connector	
Motor Fan Connector	CONN114D00	2 pole connector	
Motor Sensor Connector	CONN125D00	23 pole connector	
Power Cable Gland	BMHQPRE2	High-Strength Cable gland Pg 21	
Power Cable Gland	BMHQPRE3	High-Strength Cable gland Pg 29	

Flexium+ Configurations

Standard Configuration Flexium+ 6 and Flexium+ 8 System

Flexium+ 6 and Flexium+ 8 System

Flexium+ 6 and Flexium+ 8 are the right choice for controlling machines with relatively few axes and spindles, but with a high demand for speed and precision.

Flexium+ 6 is designed for milling and turning machines, as well as for water jet and laser cutting machines.

Flexium+ 8 offers additional features for cylindrical and flat grinding, and for gear cutting. It can also be adapted to the requirements of special-machines.



CNC System

NUM EtherCAT Terminals
NUMSafe PLC & Safe Terminals

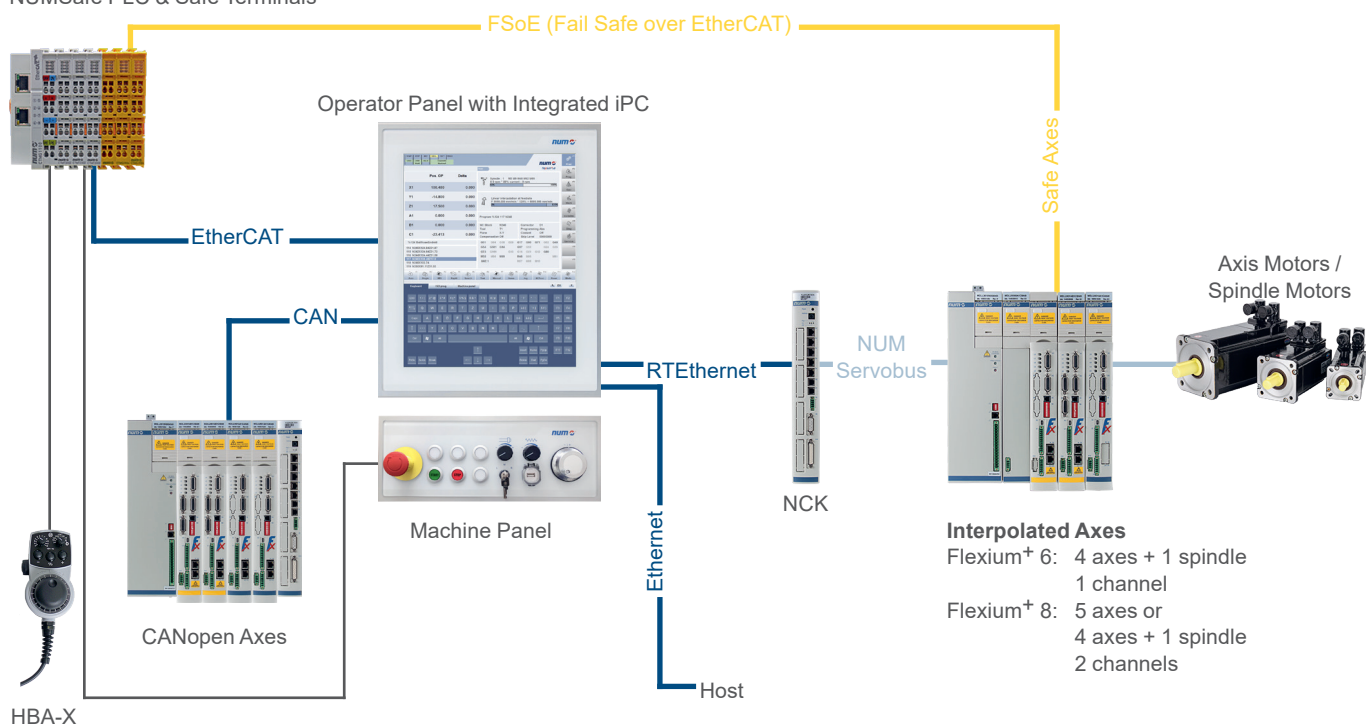

Flexium+ Configurations

Standard Configuration of Flexium+ 68 System

Flexium+ 68 System

The Flexium+ 68 system is fully scalable and can easily be adapted to customer requirements. It offers functions for the highest requirements in terms of accuracy and speed, together with application packages for the grinding, milling, cutting, etc., of work pieces, tools and gears.

flexium+

CNC System

NUM EtherCAT Terminals
NUMSafe PLC & Safe Terminals

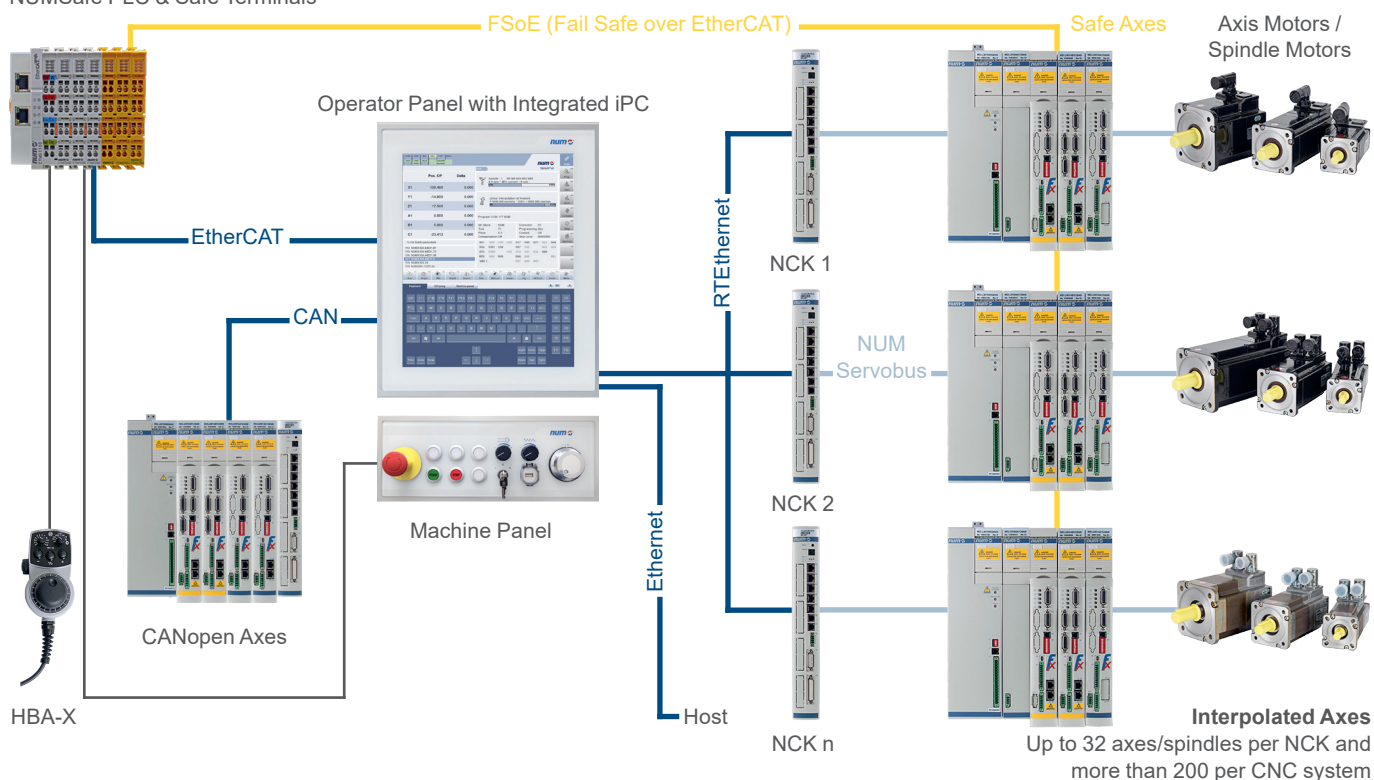

Flexium+ Multi-Panel

For operation of large machines, several HMI's are often connected modularly; a requirement Flexium+ easily meets.

With FS194i and MP05:

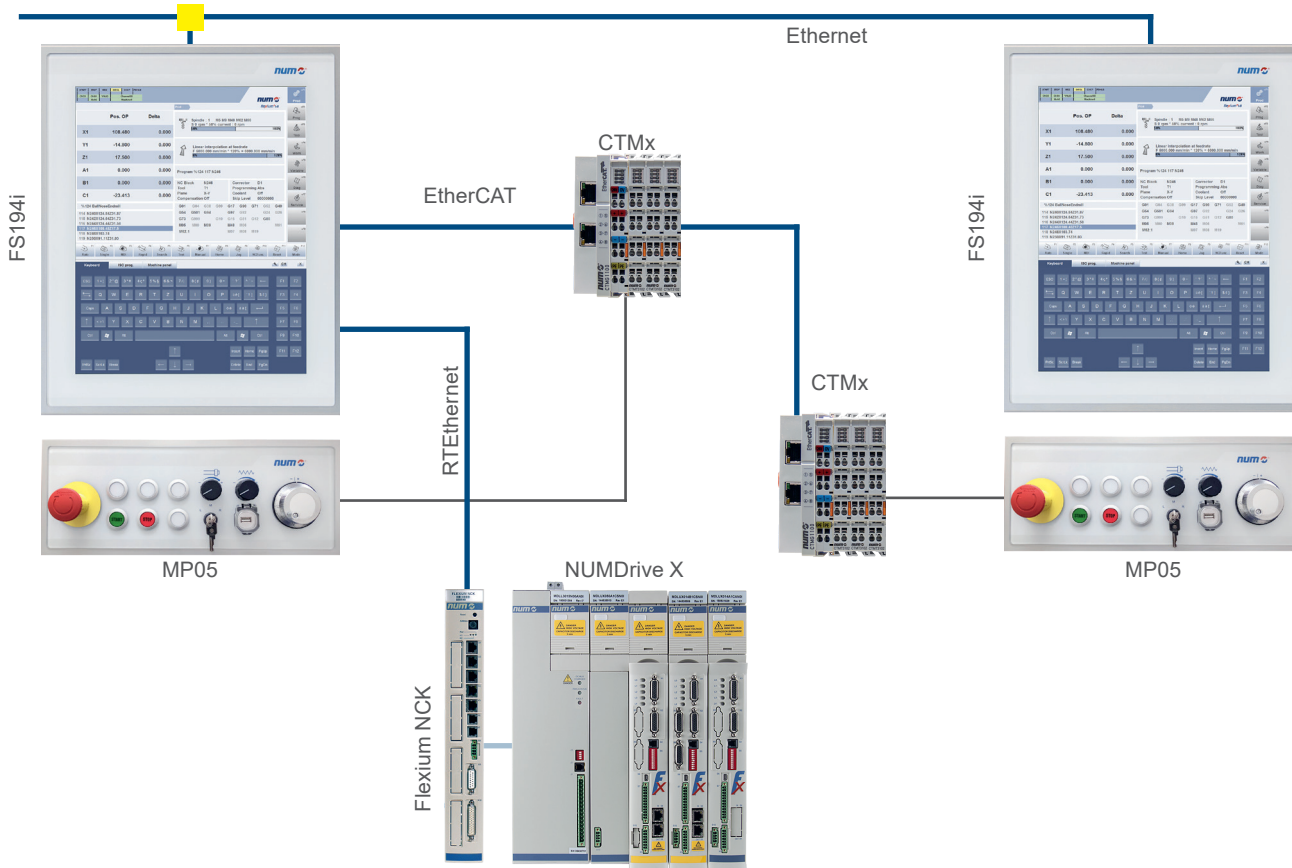

With FS154i and MP06:

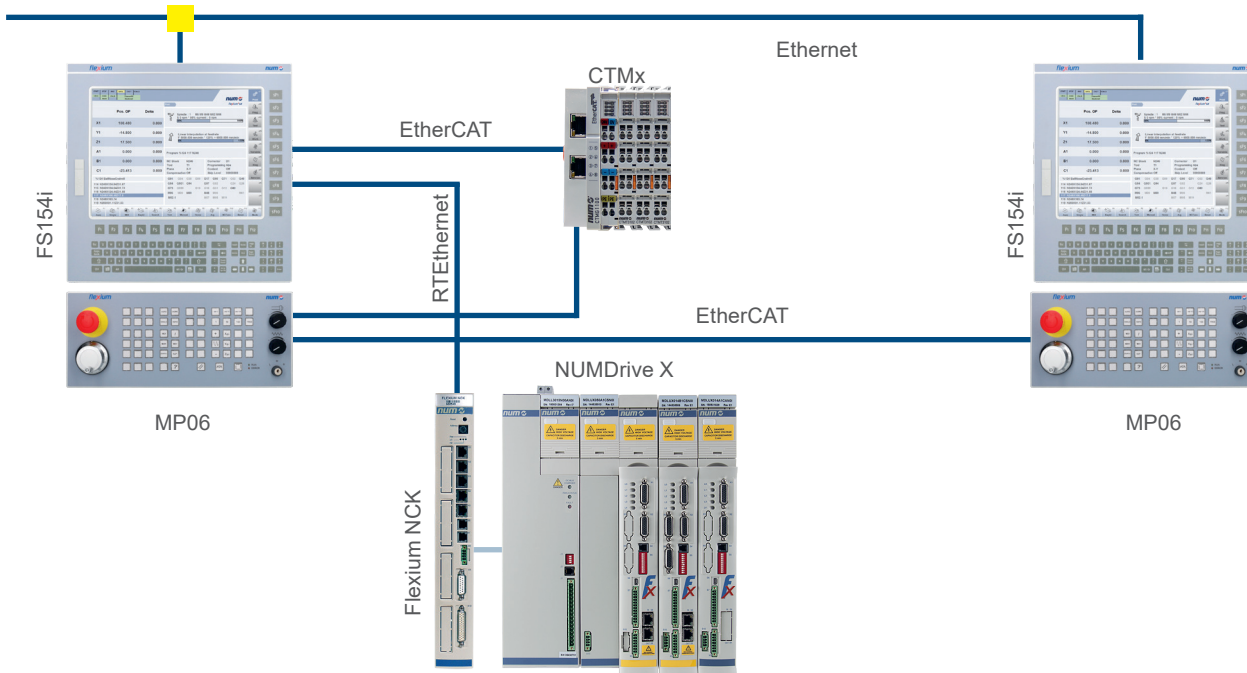

Flexium+ and Office PC

Custom applications such as CAD / CAM programs usually work best with a high performance PC and therefore it is not unusual for this computer to be replaced with a faster version a number of times during the lifespan of a machine.

This objective also applies to NUMROTOplus®.

We offer a configuration with an industrial PC (Box PC). This unit includes the real-time environment for the PLC.

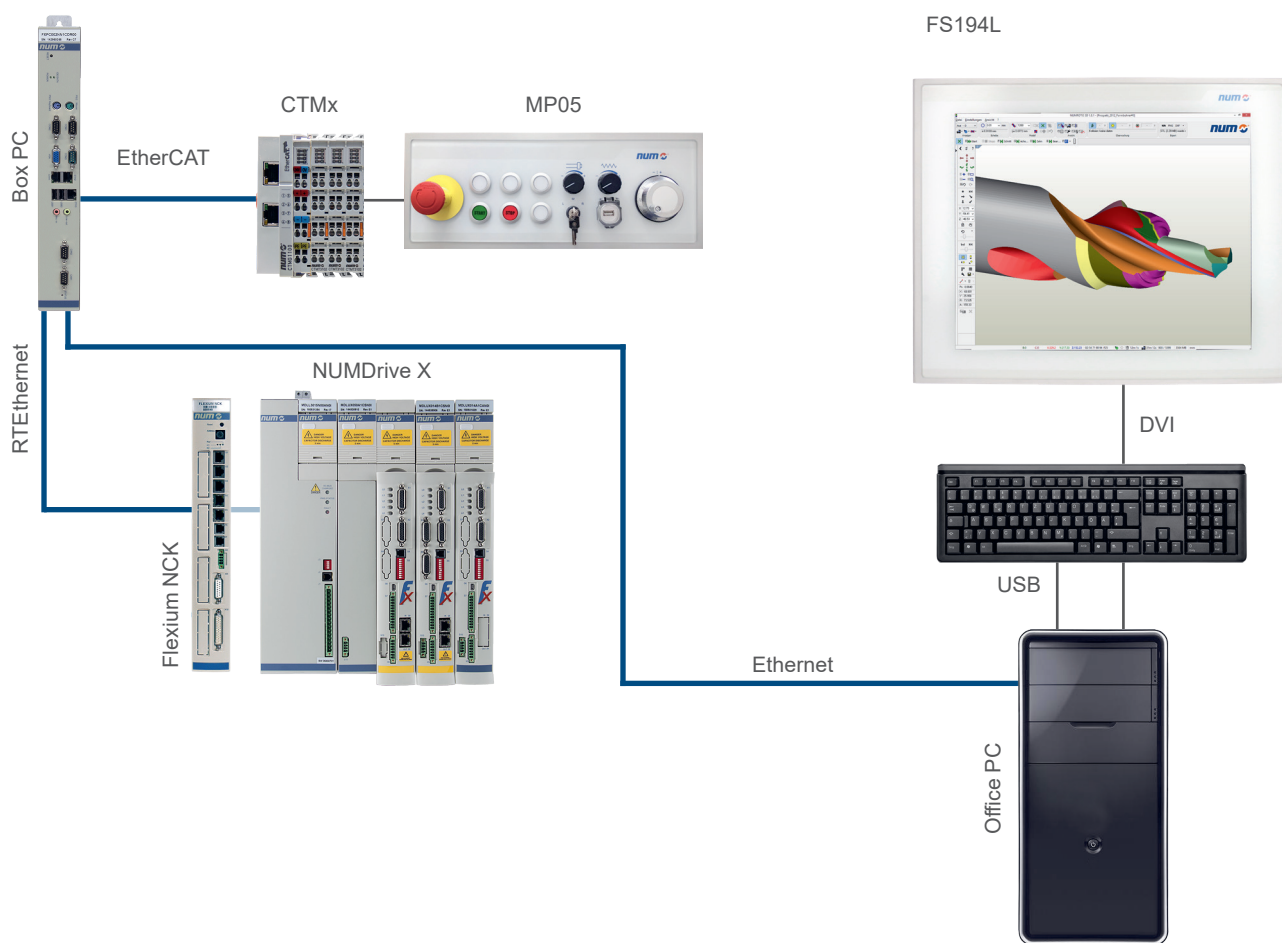

Flexium+ and Foreign Panel

Flexium+ also provides a solution for the use of customized user devices. These can be connected to the system via the industrial PC (Box PC).

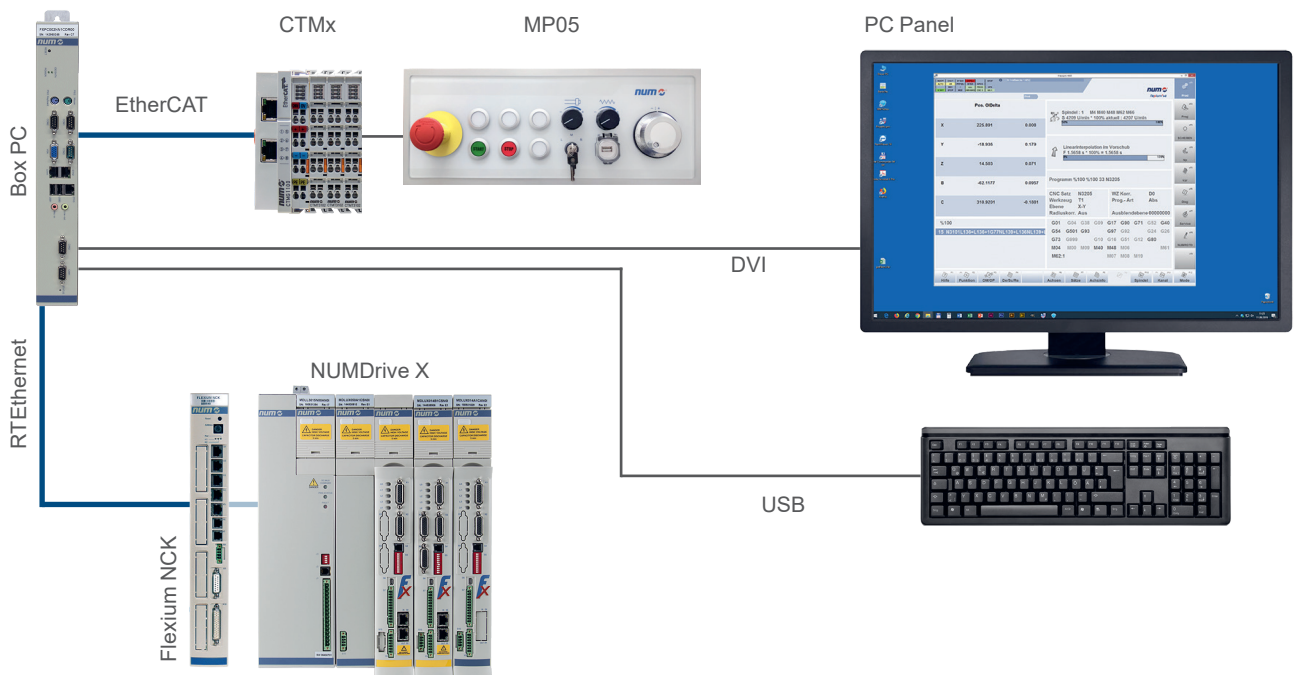

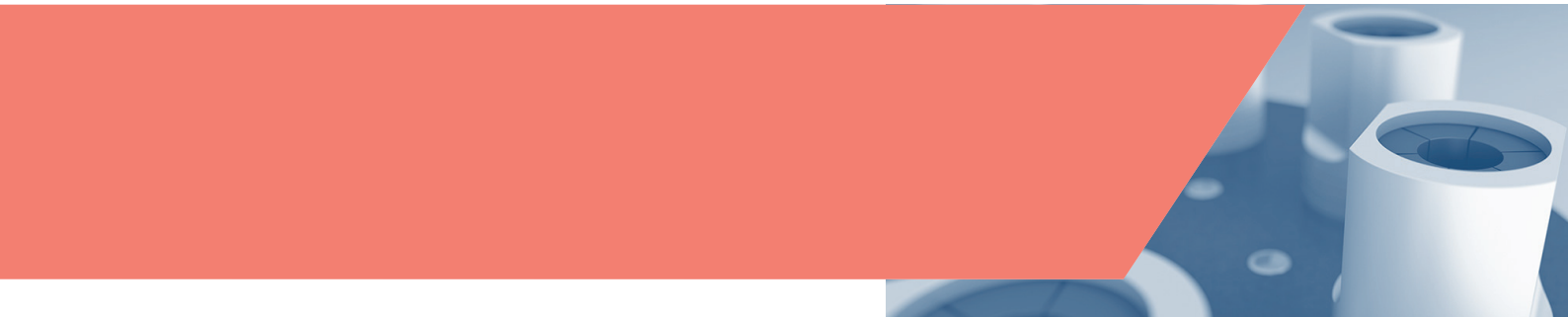

General Information

Addresses / Contacts of all NUM Subsidiaries

NUM Worldwide

Headquarters NUM Worldwide

Country	Address	Telephone	Fax, Email
Switzerland	NUM AG Battenhusstrasse 16 9053 Teufen	+41 71 335 04 11	+41 71 333 35 87 sales.ch@num.com service.ch@num.com

Subsidiaries, Distribution and Service Europe

Country	Address	Telephone	Fax, Email
Austria	NUM Verkaufsbüro Österreich Pummerinplatz 1 4490 St. Florian	+43 72 24 80 116	+41 713 33 35 87 sales.ch@num.com service.ch@num.com
Finland	NUCOS OY Keiserinviitta 16 33960 Pirkkala Tampere	+358 3 342 7100	+358 3 342 7130 oiva.viitanen@nucos.fi
France	NUM S.A.S. Immeuble le Naxos 56, rue des Hautes Pâtures 92737 Nanterre Cedex	Hotline: +33 156 47 58 06 Sales: +33 156 47 58 58	sales.fr@num.com service.fr@num.com
Germany	NUM GmbH Zeller Straße 18 73271 Holzmaden	+49 7023 74400	+49 7023 744010 sales.de@num.com service.de@num.com
Germany North	NUM GmbH Niederlassung Nord Grüner Talstraße 65 58644 Iserlohn	+49 7023 7440 22	+49 2374 9368466 sales.de@num.com service.de@num.com
Germany East	NUM GmbH Büro Ost 93142 Maxhütte-Haidhof	+49 7023 7440 21	sales.de@num.com service.de@num.com
Italy	NUM SpA Sede Legale Via F Somma 62 20012 Cuggiono (MI)	+39 02 97 969 350	+39 02 97 969 351 sales.it@num.com service.it@num.com
Spain	NUM CNC HighEnd Applications S. A. Errementari Plaza 8 Post Box 55 20560 Oñati	+34 943 78 02 65	sales.es@num.com service.es@num.com

Please see www.num.com for further contacts and most recent contact details

General Information

Addresses / Contacts of all NUM Subsidiaries

NUM Worldwide

Subsidiaries, Distribution and Service Europe

Country	Address	Telephone	Fax, Email
Sweden	ConRoCo AB Formvägen 1 777 93 Söderbärke	+46 240 65 01 16	+46 240 65 01 21 info@conroco.com
Switzerland	NUM SA Erlenstrasse 32 2555 Brügg	+41 32 346 50 50	+41 32 346 50 59 sales.ch@num.com service.ch@num.com
United Kingdom	NUM (UK) Ltd. Unit 3 Fairfield Court Seven Stars Industrial Estate Wheler Road Coventry, CV3 4LJ	+44 2476 301 259	+44 2476 305 837 sales.uk@num.com service.uk@num.com
Turkey	NUM Servis Türkiye Feyzullah Cad. Beyazköşk Apt. 17 / 12 34840 Maltepe-Istanbul	+90 216 371 40 20	+90 538 425 66 11 numserviceturkiye@yahoo.com.tr

Africa

Country	Address	Telephone	Fax, Email
Algeria (Maghreb)	NUM S.A.S. Immeuble le Naxos 56, rue des Hautes Pâtures 92737 Nanterre Cedex	Hotline: +33 156 47 58 06 Sales: +33 156 47 58 58	+33 1 56 47 58 90 sales.fr@num.com service.fr@num.com
South Africa	MACHINE TOOL PROMOTIONS (Pty) Fraser Street 12 Vanderbijlpark 1911	+27 16 9311564	+27 16 9338979 abraham@mtpsa.co.za

America

Country	Address	Telephone	Fax, Email
USA	NUM Corporation 603 East Diehl Road, Suite 115 Naperville, IL 60563	+1 630 505 77 22	+1 630 505 77 54 sales.us@num.com service.us@num.com
Brazil	LOSUNG Technical Assistance and Comerce Ltda. Av. Anápolis, 500 06404-250 Bethaville-BARUERI-SP	+55 11 419 13 714	+55 11 419 58 210 contato@losung.com.br
Mexico (Central America)	VISI Series México, S.A. de C.V. Sierra de Ahuacatlan, No. 136 Villas del Sol Santiago de Querétaro, Qro. CP 76046	+1 442 248 2125	+1 442 223 6803 service.mx@num.com

Please see www.num.com for further contacts and most recent contact details

NUM Worldwide

Subsidiaries, Distribution and Service Asia/Australia

Country	Address	Telephone	Fax, Email
China	NUM Numerical Control Technology (Shanghai) Co., LTD No. 604, Building A, Chamtime Plaza, No. 2889, Jinke Road, Pudong New District, Shanghai 201203	+86 21 6882 0958	+86 21 6882 0959 sales.cn@num.com service.cn@num.com
	NUM Numerical Control Technology (Shanghai) Co., Ltd Guangzhou Branch Rm. 1005, Building C3, Grand Tech Park, No. 28, Kaitai Avenue, Huangpu District, Guangzhou	+86 20 2232 5686	sales.cn@num.com service.cn@num.com
Taiwan	NUM Taiwan Ltd. 7F-2 No. 536, Sec. 2 Taiwan Boulevard Taichung City 40353	+886 4 2316 9600	+886 4 2316 9700 sales.tw@num.com service.tw@num.com
Thailand	Gsixty Co. Ltd. 508/51 Sukhontasawat Road Ladphrao, Bangkok 10230	+66 2 578 34 54 +66 896 51 59 50	+66 2 578 34 54 jameschaput@hotmail.com
Australia	Australian Industrial Machine Services Pty. Ltd. 28 Westside Drive Laverton North Victoria 3026	+61 3 9314 3321	+61 3 9314 3329 enquiries@aimservices.com.au
India	NUMIndia Automation Private Limited N9, 2 nd Floor, 24 th Main JP Nagar 1st Phase, Bangalore 560078 (IN)	+91 99451 56423	sales.in@num.com service.in@num.com

Please see www.num.com for further contacts and most recent contact details

Declaration of Conformity

The product described in this catalog, used in conformity with the relevant manuals, fulfills the basic requirements of Electromagnetic Compatibility and of Electrical Safety as prescribed by the Directives :

2014/35/EU "Low voltage (LVD)" dated 29/3/2014
2014/30/EU "Electromagnetic compatibility (EMC)" dated 29/3/2014

The products of this catalog are intended to be incorporated into machinery or assembled with other machinery to constitute products covered by the council directive. Commissioning is forbidden until the products have been integrated in a machine that conforms with the Directive 2006/42/EC.

Export terms for NUM products

1. Because of their technical characteristics or in some case their utilization, certain of NUM's products may be required to comply with the requirements of Swiss or European regulations and/or US regulations concerning control of the final destination.

Relevant information is given on our purchase order acknowledgments, invoices and delivery notes.

These provisions apply to NUM's products so identified on our purchase order acknowledgments, invoices and delivery notes.

2. Accordingly, the purchaser undertakes to fully comply in all respects with the regulations of his country and, as the case may be, with Swiss, European and / or US regulations relating to the control of final destination of dual use products.

The purchaser undertakes to introduce and to follow its own business control procedures in order to ensure that, in respect of the resale of Dual Use Products, such national legal obligations will be implemented.

3. In any case, the purchase orders received by NUM shall be accepted subject to NUM obtaining any required authorizations.

Imprint

© Copyright NUM AG

Publication date: January 2024

Editor and layout: Jacqueline Böni and Larissa Kühne

Publisher: NUM AG, Battenhusstrasse 16, 9053 Teufen, Switzerland
sales.ch@num.com, www.num.com

All rights reserved. No part of this document may be copied or reproduced in any form or by any means whatsoever, including photographic or magnetic processes. The transcription on an electronic machine of all or part of the contents is forbidden.

Subject to technical changes, errors and misprints excepted.

The software mentioned herein is the property of NUM AG. Each copy of the software confers on the holder a non-exclusive license strictly limited to use of the said copy. No copy or other forms of duplication of this product is authorized, with the exception of backup copies of the software.

The physical, technical and functional characteristics of the hardware and software products and the services described in this document are subject to modification and cannot under any circumstances be construed as contractually binding.

Windows is a registered trademark of Microsoft Corporation.

Complete CNC Solutions Worldwide



NUM systems and solutions are used worldwide.

Our global network of sales and service locations guarantees professional service from the beginning of a project to its execution and for the complete life cycle of the machine.

NUM has service centers around the world. Visit our website for the current list of locations.

www.num.com



Follow us on our social media channels for the latest information on NUM CNC Applications.

- [linkedin.com/company/num-ag](https://www.linkedin.com/company/num-ag)
- WeChat-ID: NUM_CNC_CN
- twitter.com/NUM_CNC
- facebook.com/NUM.CNC.Applications