



NUM information

JOURNAL FOR CNC-TOTAL SOLUTIONS

- 04 **Engineering Highlights**
- 16 **Revoc AG** – Revoc provides specialist retrofitting of Kellenberger cylindrical grinding machines
- 18 **SOS Elektronik** – Successful retrofit for a new life of a Walter Power with NUMROTOplus
- 20 **McQuade Industries, Inc.** – CNC upgrade program provides US cutting tool manufacturer with major productivity advantage
- 22 **Grupo Plasma Automation** – High speed laser cutting machine uses novel CNC techniques to accelerate throughput
- 24 **APTE/Mécanuméric** – Flexium⁺: Performance and durability
- 26 **Prototyp-Werke GmbH** – Own grinding software know-how combined with the NUMROTO infrastructure

Editorial Peter von Rüti, CEO NUM Group



Dear readers,

Psychologists say that “hardly anything is as difficult to bear as uncertainty”. Not knowing what will happen tomorrow frightens us, even though that is actually our everyday life. With routines we give ourselves the feeling of predictability and security. So what can we trust in uncertain times? Fundamentally, just good, solid values. Here at NUM, we rely on our long-standing values and principles. We advise and supply our customers comprehensively and offer extensive know-how in the automation of production machines. Your requirements and needs play a central role in our company. Our expertise – the functions and applications which are constantly being developed in line with customer needs – embodies rock-solid values on which you can implicitly rely.

More than ever, experience counts. Quite a few of our employees have been using their skills for many years in the development of our software, hardware and application projects. We are very proud of our employees’ long-standing know-how and commitment to NUM, and would like you to benefit from this in your economic development.

Development in the virtual world: with digital twins, we are using cutting edge technology to build a bridge between the real world and a virtual world. A digital twin is a virtual recreation of a real machine based on data and algorithms. This allows functions, machines and even entire machine parks to be tested in a virtual

environment, i.e. before the functions or the machines actually exist. This is an important technology trend which, in certain cases, can reduce the “time to market” and thus save development costs.

Our new NUMcut HMI for waterjet, laser or plasma cutting machines has an integrated CAM/postprocessor module. This HMI allows geometry data entered by customers on a website, for example, to be sent directly to the machine. This means that no additional CAD/CAM system with post processor is necessary. This application is very much in line with Industry 4.0, and the CNC control also has a number of supporting and efficiency-enhancing functions such as AFC (Adaptive Feed Control) and VOC (Variable Offset Control).

“According to psychologists, few things are as difficult to bear as uncertainty. With NUM as your reliable partner, you gain certainty.”

Peter von Rüti, CEO NUM Group

Targeted non-circular grinding: in the latest version of the NUMgrind HMI, non-circular grinding has been added. This update makes it possible to grind eccentric and non-circular workpieces with any shape in the simplest possible way thanks to dialog-guided input.

In this current issue of NUMinformation, our customer reports from around the globe lead you to companies in Germany, Switzerland, France, Mexico and the USA. With these partners we have implemented cost and time efficient machine automation projects. For example, a CNC laser cutting machine, a 5-axis portal deburring machine, a tool grinding machine and many more. Let us convince you of our successful projects and inspire you for future investments.

I hope that you enjoy reading this issue of NUMinformation and I look forward to meeting you personally at one of the next trade fairs.

Peter von Rüti
CEO NUM Group

Imprint

Publisher NUM AG
Battenhusstrasse 16
CH-9053 Teufen

Phone +41 71 335 04 11

sales.ch@num.com
www.num.com

Editor & Layout Jacqueline Böni
Andreas Hahne

© Copyright by NUM AG Reuse allowed with reference only, specimen copy welcomed.

NUMinformation is published once a year in English, German, French, Italian and Chinese.

NUM expands to India

NUM AG has opened a branch in Bangalore in November 2019. With this expansion in Asia, the international company with headquarters in Teufen, Switzerland, further reinforces its position as a technology leader in the field of CNC controls. With the expansion to India, NUM increases its local presence there as well as its customer-oriented sales and service offering.

“The location in Bangalore will enable us to respond much more quickly to customer inquiries and further expand our brand in the region. We have been well represented in China and Taiwan for many years and would now like to further strengthen our position in Asia”, says Rajesh Nath, Managing Director of NUM India. This latest expansion secures jobs worldwide, as well as creating new employment opportunities in India.



Traditional Indian light ceremony performed by the management on the opening day

Copyright of NUMROTO software in China

We are pleased to announce that we are now officially in possession of the copyright of NUMROTO software in China.

This will make it easier for us and our lawyers to take action against the use and sale of unlicensed versions of NUMROTO worldwide and to hold guilty users and providers accountable accordingly.

How do you recognize an illegal version of NUMROTO?

If you have a machine that does not have a NUM CNC control and still uses NUMROTO then it is for sure an unlicensed and therefore illegal version of NUMROTO.

If you want to have the authenticity of NUMROTO checked, just send us your license file (keyfile) with the extension .nky or .nk4, together with the name of your company. If you find that you are using an illegal version of NUMROTO, please contact us. We will try to find a solution to the problem together.



Events

NUM Event Calendar 2020/2021

GrindTec 2020
November 10–13, in Augsburg, Germany
Hall 7, Booth 7100

IMTEX 2021
January 23–28, in Bangalore, India

Grinding Technology 2021
March 2–4, in Tokyo, Japan

TIMTOS 2021
March 15–20, in Taipei, Taiwan

CIMT 2021
April 12–17, in Beijing, China



The NUMgear family grows

Software wizard for probing



The NUMgear family of technologies is growing

Flexium CAM, NUM's development environment for user-friendly interfaces, and the ultra-precise, flexible, and scalable MLEGB electronic gearbox, are the proud parents of the NUMgear family.

NUMgear Hobbing

The oldest child in the family is NUMgear Hobbing, the hobbing solution for new machines and retrofits. It has been tried and tested for many years and impresses everywhere with first-class quality results. Hobbing is still the fastest process for the production of involute external gears.



NUMgear Shaping

NUMgear Shaping is the brother of gear hobbing. Internal involute gearings, i.e. rings, are shaped. The more compact gears become, the more likely internally toothed rings are used.



NUMgear Threaded Wheel Grinding

NUMgear's Threaded Wheel Grinding produces the high-precision surfaces on involute external gears that make a transmission that lasts longer than the rest of the car and are virtually unnoticeable while driving. NUMgear threaded gear grinding with the help of the MLEGB can achieve a surface quality of DIN 1 and better. Fast centering of the gear to fix the tooth position and precise dressing of the grinding worm make the process fast and reliable.



NUMgear Profile Grinding

NUMgear Profile Grinding is the most versatile kid in the family. Each tooth gap is ground individually, whereby the grinding wheel is dressed exactly to the desired tooth and gap shape. In this way, a wide variety of tooth shapes can be produced, from the modified involute to the cycloid. NUM's profile grinding allows the calculation and correction of both involute and cycloid profiles. The module calculates the path of the dresser and controls the process from dressing to grinding. Profile grinding is suitable for external and internal gears.



NUMgear Skiving

NUMgear Skiving is the infant of the family. Although the technology is not new, it did not become really productive until a hundred years after the patent application. The most important factor here is the coupling between tool and workpiece. This is guaranteed by the MLEGB at speeds of 16 000 rpm and NUM's motors and drives with nanoprecision. Skiving is equally suitable for internal and external gears.

The NUMgear family will continue to grow and cover new technologies. In this segment, too, NUM solutions offer maximum flexibility and openness. Each of the modules can be adapted in its function and operation according to customer requirements.

Software wizard provides graphical guidance for workpiece probe measurement

CNC machine tool operators now have an easy means of performing probe measurements of parts and tools on the shop floor.

A new software option from CNC specialist NUM dramatically simplifies measurement cycles during CNC machining processes.

Designed specifically for ease-of-use, the software employs graphical guidance techniques to completely remove the need for CNC machine operators to have any G-code programming experience. It is likely to be of special interest to machine shops seeking to enhance their process verification or increase the throughput of precision parts.



NUM's new software wizard enables CNC machine tool operators to easily handle probe measurements of parts and tools

Supplied in the form of a software wizard for use with any of NUM's latest-generation Flexium+ CNC systems, the new option accommodates all standard probe measurement cycles for parts and tools. For maximum versatility, there are 17 different workpiece measurement routines and four probe calibration routines, plus two fixed probe calibration and cutter length pre-setting routines. The system also offers six measurement routines specifically for use on milling machines.

Each routine provides unambiguous guidance throughout its respective measurement cycle, effectively automating the process. The user is first prompted to specify the technological data for the measurement, such as the feed rate and probing speed, followed by preparatory data such as the approach and starting positions, and input and output data specific to the selected cycle.

Once a measurement cycle has been initiated by the operator, all probe positioning can be handled completely automatically by the CNC machine. The probe stylus is fully protected against collision with the part in the working environment, with any error being signalled to the CNC system and causing an immediate stop. The software includes full management of the RTCP (rotation tool center point) function, to handle inclined coordinates inside the measurement circle.

NUM's probe measurement guidance option brings a new level of flexibility to CNC machine tools. Its advanced capabilities include complex tasks such as measuring the width of a rib/web and the mid-point for a paraxial probing movement, measuring the diameter and center of a bore or a boss by means of four points, measuring the angle of an oblique surface by probing along the third axis, and vectorial measurement of a bore or boss by three points.

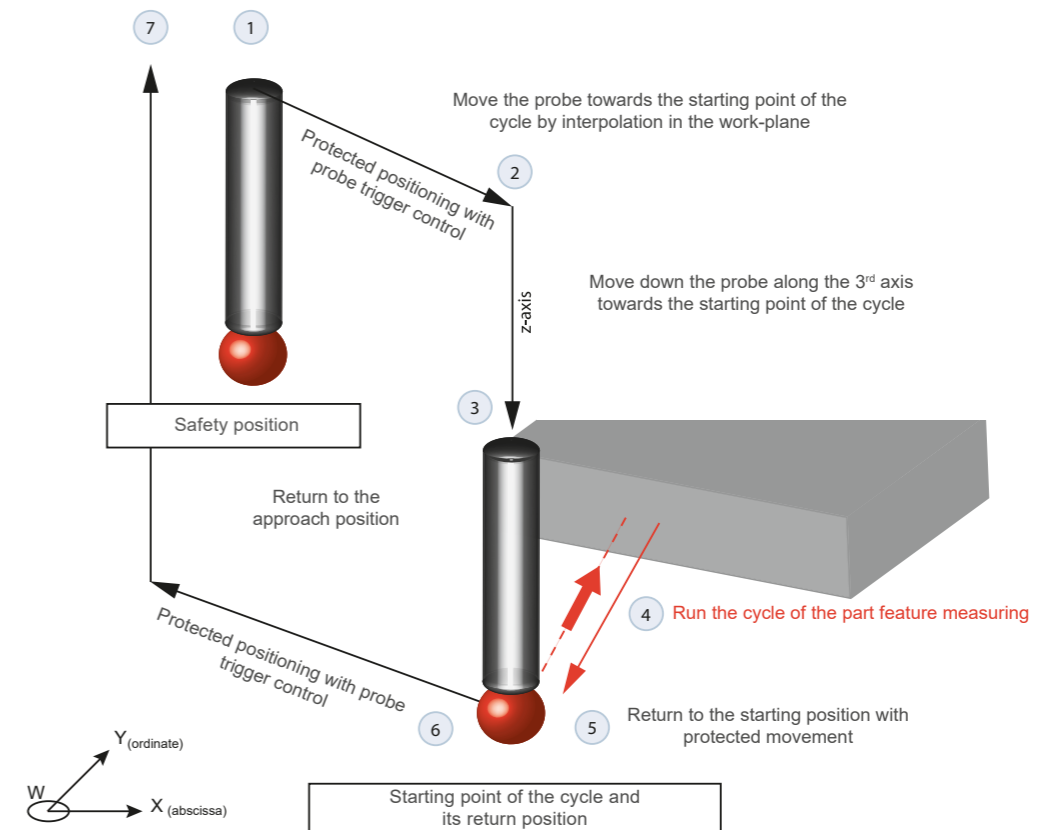

NUM's new probing software option extensively automates measurement cycles during CNC machining processes

New software for CNC cutting machines

New software for CNC cutting machines features integrated CAM/postprocessor module to simplify creation of part programs

Broad spectrum of functions that cover water jet, laser and plasma beam cutting applications.

CNC specialist NUM has launched a new HMI (human-machine interface) software package that features a fully integrated CAM/postprocessor module to further simplify and accelerate the creation of part programs for CNC cutting machines. The software also includes two new real-time analytical functions for water jet cutting applications, designed to improve cutting accuracy and quality.

Many of the world's leading manufacturers of water jet, laser and plasma beam cutting machines nowadays choose to base their products on NUM's CNC systems, in no small part due to the inherent functionality and control flexibility of the company's Flexium platform. Launched in 2012, Flexium has acquired an enviable reputation amongst machine manufacturers and end users for its control flexibility and ease of use – and NUM continuously enhances the platform to address users' changing needs and new cutting machine technology.

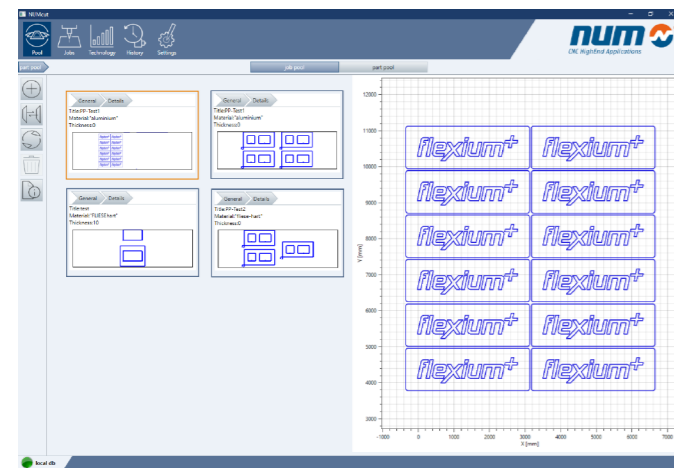

Figure 1: Pool of existing files

The latest version of NUM's software for CNC cutting machines is the result of significant development work. It embodies Industry 4.0 connectivity principles and features an entirely new HMI, known as NUMcut, which incorporates functionality that previously required separate CAD/CAM postprocessor computing resources.

Users generally prepare part programs for CNC cutting applications upstream of the machine in the production area, on some form of CAD/CAM system. A key element of this work involves post-processing the resulting ISO file to incorporate machine-specific cutting data. This is a highly iterative procedure, which can lead to interpretation errors and time-consuming resolution of machining issues.

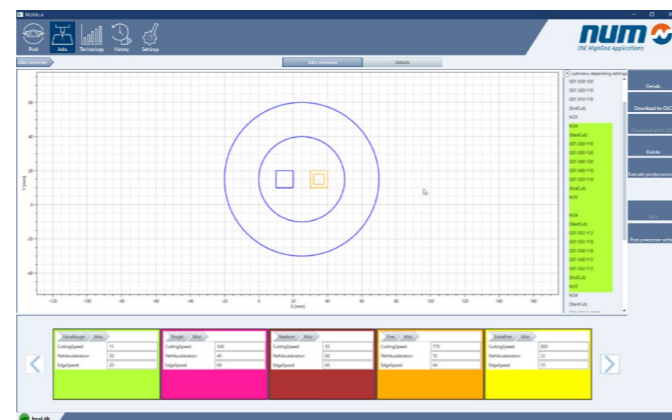

Figure 2: Assign cut quality

To shorten the path, NUMcut includes a powerful, machine-resident CAM/postprocessor module. The only data that needs to be transferred to the machine prior to commencing cutting operations concerns the geometry of the part and the desired quality of each cut. This data can be derived from virtually any type of CAD/CAM software, running, for example, on a standard PC.

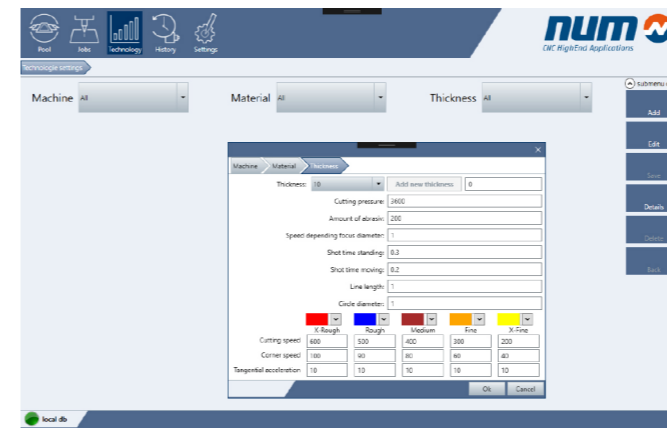

Figure 3: Input Mask Technology Database

All other necessary data, such as cutting speeds, abrasive quantity as a function of the material to be cut, etc., are calculated by the control system itself. The CAM/postprocessor module utilizes a technology database containing all the relevant information needed by the control system in order to automatically generate an executable part program. The values in the database are preloaded by the machine manufacturer, and can be modified or added to by users if necessary – for example, to accommodate new materials.

The database itself – which effectively contains the expertise of the production company – can either be located on individual cutting machines, or stored on a network drive so that it can be accessed by several machines.

The NUMcut HMI displays all files that are available to the machine operator in a clear, unambiguous style. Using the CNC system's touch-sensitive screen, the operator can determine each successive machine action simply by clicking and dragging icons from the pool of files into a 'job list'. Both the job that is currently being processed by the machine, and the current position of the cutting tool within the job, are marked graphically. If required, the operator can change the job list while it is being processed to accommodate different production needs, such as express deliveries.

NUMcut also offers two real-time analytical functions for water jet cutting applications. During water jet cutting, the processing speed needs to be decreased before corners in order to reduce the wake of the cutting jet and thus maintain the cutting quality. Using data from the technology database, NUMcut's adaptive feed control (AFC) function analyses the path geometry and automatically optimises the cutting speed to best suit the curve radius or corner angle.

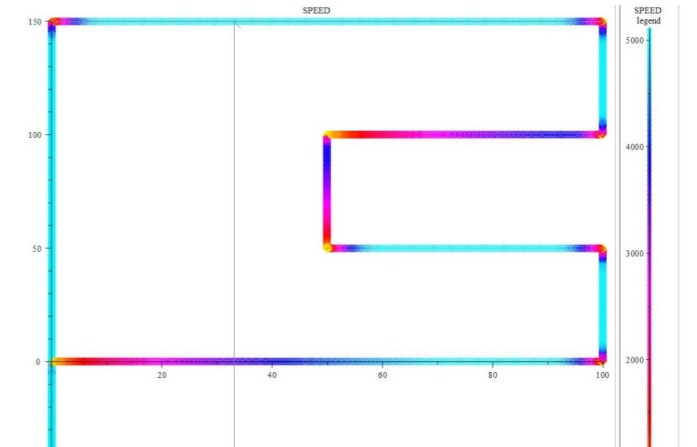

Figure 4: Adaptive cutting speed

Another inherent characteristic of water jet cutting is that the shape of the kerf changes with the cutting conditions, which means that a significant change of gap width can develop, depending on the speed. If this inaccuracy needs to be compensated for, NUMcut offers a variable offset control (VOC) function. This allows the cutting path to be changed automatically, so that the final contour of the part remains true to size despite the changing radius of the cutting jet, thereby maintaining the dimensional accuracy of each cut part.

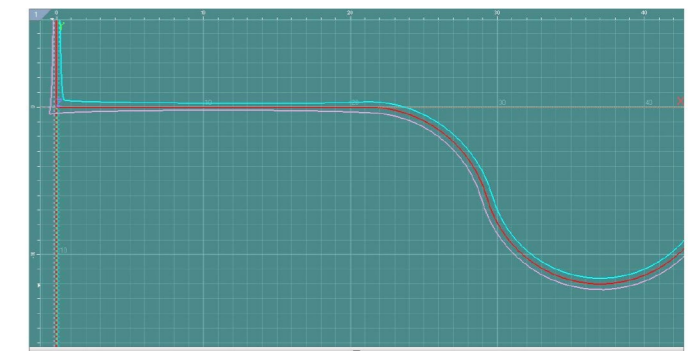

Figure 5: Speed-dependent kerf width

Using artificial intelligence for fault prevention

Non-circular grinding made easy



NUM Diagnostics and fault prevention using artificial intelligence (AI)

During a machine's lifetime, different failures can cause interruptions lasting from a few hours to several days. A machine stop means a delay in deliveries, which can have a high impact on service quality and costs (and in some cases, result in penalties).

To reduce the impact of machine downtime, the prediction of failures is very important; it allows spare parts to be sourced in advance and an intervention to be planned in the most suitable period before the fault happens. NUM offers two different diagnostic and fault prevention solutions, based on two different concepts: a software application called NUMmonitor and a diagnostics and prevention solution that uses AI (artificial intelligence).

Both these solutions aim to predict a machine's mechanical problems such as: an increase of friction, backlash, vibration, instability... and electrical problems such as: a reduction in motor efficiency (caused by magnets derating for example), the wrong encoder offset, a missing phase, major drive problems...

The two solutions employ different approaches:

- NUMmonitor creates a machine "fingerprint"; by periodically checking the machine against the fingerprint, it's possible to predict derating and potential failures
- Diagnostics and prevention using AI allows "on-line" machine behavior to be monitored, and warnings to be generated in the event of deviant phenomena (failures, aging, lubrication issues etc.).

Let's see how NUMmonitor works in more detail; by running the machine with a test part program it is possible to automatically create an averaged curve of a certain axis variable (axis current or load, for example). Once the averaged curve is generated, minimum and maximum envelope curves (the user can define the rules) are created. These envelopes define the maximum deviation of a certain variable.

Periodically checking the machine, by means of the same test part program, enables deviations and derating to be identified. NUMmonitor, used in conjunction with a NUM Flexium+ system, does not require any additional device/sensor and the complete checking process can be automated. As well as for the fingerprinting function, NUMmonitor can also be used for process (machining) monitoring.

A different approach uses artificial intelligence (AI) to implement diagnostics and fault prevention functionalities; once a machine has been completely commissioned and is ready to start production, a machine learning process starts.

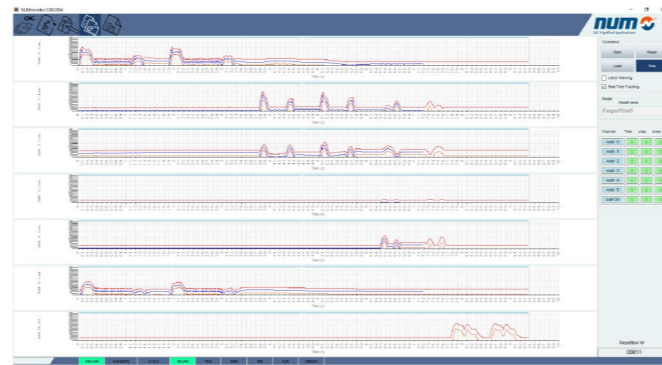

Example of a machine where 7 axes are monitored. Blue: averaged axis current value measured when machine is new and tested, Red: minimum and maximum envelope curves

By using the machine in automatic mode (for example during standard machining situations), various variables are collected and by means of such data, a neural network is designed and tuned. The NUMai software application implements the designed and tuned neural network; it runs on the machine's industrial PC (the same PC used for the machine's HMI) and continuously emulates the machine's normal behavior in on-line mode.

If after a certain time, the machine behavior is changing due to aging, failures, lubrication issues, etc., the NUMai software will identify the deviation and set a warning! To summarize the principle: a neural network learns how the machine works in normal conditions, if deviations (for example a mechanical problem) occur then the phenomena is identified! Also, in this case, the solution is completely integrated and no additional sensors are needed.

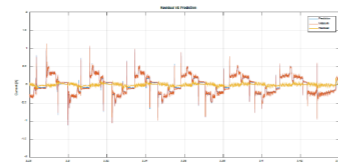

This example shows the comparison between the prediction of a variable (blue) made by a neural network and the measured value of the variable (red). The residual error is shown in yellow

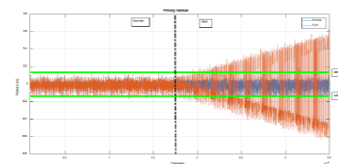

This example shows the residual error of an estimated variable, then a fault occurs (right side), the residual error increases and a warning is set

Non-circular Grinding

If we look at a cam disc, for example, we see that even non-circular workpieces have to be ground. With cylindrical grinding, a perfectly round shape should be achieved, whereas with non-circular grinding we want to obtain the defined non-circular shape with the corresponding surface quality.

NUM has extensive experience in grinding applications. In addition to tool grinding, NUM also offers external and internal cylindrical grinding, surface grinding and centerless cylindrical grinding with CNC systems specially tailored to the respective application.

Non-circular grinding is a specialty of cylindrical grinding with the NUM CNC systems. The C-axis is interpolated or synchronized with the X- and Z-axes in such a way that shapes can be ground that cannot be produced with a conventional cylindrical grinding machine.

The following pictures show some possible shapes or workpieces that can be ground. There are no limits to the variety of shapes for convex (outwardly curved) surfaces. With concave (inwardly curved) surfaces there are of course process-related geometric limitations.



Cam Shaft

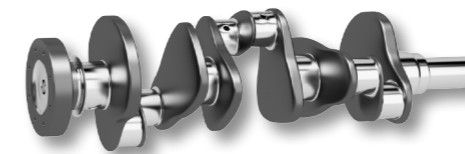

Crankshaft

Functions

Non-circular grinding is an extremely complex grinding application, since the non-circular contour leads to constantly changing engagement and movement conditions on the workpiece to be ground. Special software is therefore required to ensure that out-of-round grinding is successful. With NUMgrind, the closed shape of the "workpiece" is defined in the XY plane. However, grinding is performed by interpolating or synchronizing the X axis with the C axis (spindle). An axial movement in Z can be added to this. This is carried out by means of oscillation or multiple grooving. The contour is transformed in the Flexium+ NCK from the XY plane into an XC plane and the corresponding compensation and in-feed movements are calculated taking the grinding wheel diameter into account. The contour can be given a speed profile, which is of course also transformed, whereby the control automatically takes the defined maximum speeds and acceleration into account. These non-circular grinding cycles are included in the NUMgrind non-circular grinding package of Flexium+, ready for use.



Punch

In the associated HMI, a large number of predefined shapes are available, making part programming much easier. However, profiles can also be imported and adapted. After filling out the dialog pages and determining the machining sequence, the NUMgrind HMI creates the necessary part program, which can then be run on the machine.



Section of the input page for the egg shape

With Flexium 3D, grinding movements and material removal can be simulated. Example:

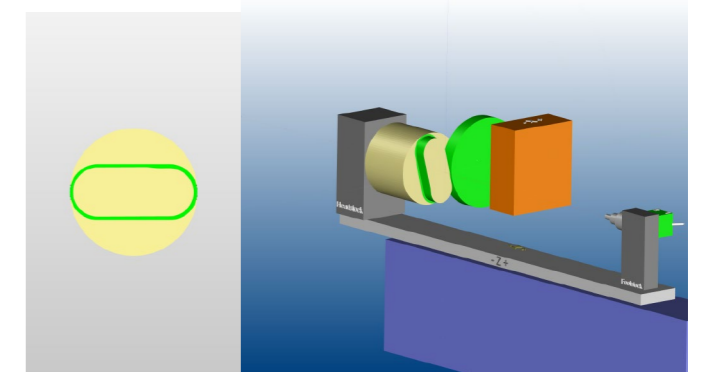

3D simulation non-circular grinding

The NUMgrind package contains comprehensive grinding cycles for external/internal cylindrical grinding and optional non-circular grinding. It is supplied as a complete turnkey package, but can be individually expanded with additional cycles and functions.

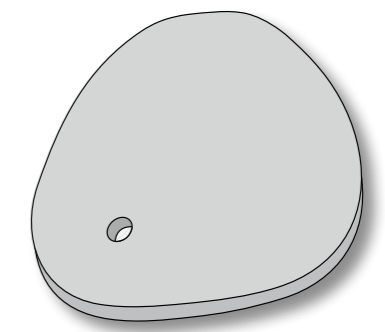

Cam plates

Digital Twin – real objects in the digital world

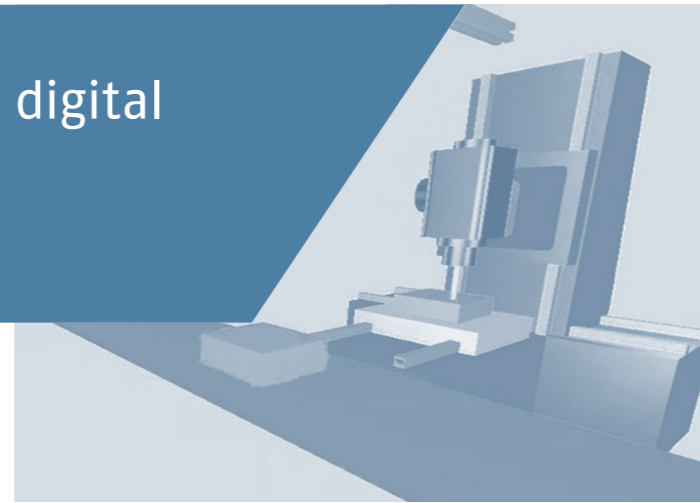

Digital Twin

The development of digital twins is one of the current top technology trends and is one of the pillars of Industry 4.0, which aims to reproduce a real object in the digital world as closely to 1:1 as possible.

A Digital Twin contains data and algorithms and sensors connecting it to the real world. A digital twin is a virtual model e.g.

- of a product
- of a process (machinery, plant, production)
- a service (compliance with delivery times, quality control)

These objects, processes or services need not yet exist in the real world. They can just as well be in the development phase.

What are the benefits of coupling the real and virtual worlds? Coupling enables parallel development of mechatronics, monitoring of systems (understanding and processing problems before they even occur; avoiding downtime) and analysis of data. When used correctly, costs and time to market can be reduced.

Product Twins

As a control system manufacturer we want to support our customers in the production and maintenance of their machines. Therefore the focus of this article is on the creation of a digital twin of their product, the product twin. It is created at the beginning of the development phase and is extended step by step until the real product exists. It consists of the product structure as well as other information such as the geometry in an M-CAD file, the electrical schematic in an E-CAD file, the software etc. This enables teams to carry out development in parallel, and very efficiently.

Without digital twins, the mechanical machine components are not brought together with the controller until commissioning. This makes it lengthy, risky and costly, as problems are not detected until late in the day. The basis for real commissioning is the real machine, which does not exist during the development phase, but only at a later point in time. The digital twin, on the other hand, is already available at an early stage and can be used for virtual commissioning during the development phase, before the first mechanical parts are manufactured and exist in reality. The digital twin 'represents' the mechanics, actuators and sensors of the later real machine and offers a realistic representation based on 3D machine simulation. This opens up new possibilities for the development of the control software, as it can be tested and optimized against the digital twin at an early stage.

Structure

A system with a digital twin consists of three elements:

- Real object
- Digital twin in (partially) virtual space
- Information that links the two objects together

There are basically two types of digital twins:

- Hardware in the Loop (HiL)
- Software in the Loop (SiL)

In the case of 'Hardware in the Loop', the digital twin includes a real controller. This means that the PC with the software of the digital twin is connected to the controller via cabling. On the controller, the current software version is executed in interaction with the simulation model in the digital twin. Signals are exchanged between the two systems, and the 3D visualization in the digital twin displays the program sequence realistically.

In the case of 'Software in the Loop' the digital twin communicates with a virtual controller. The entire functionality is located on a PC. This is a possibility which can be advantageous in an early development phase, when the real control is not yet available.

Virtual commissioning

By means of virtual commissioning, efficiency can be increased and development times can be reduced. Also, a significantly higher level of development of the software is achieved before the start of commissioning on the real machine. As a result, machine commissioning can be carried out in a shorter time, more cost-effectively and with less risk potential.

A further application of virtual commissioning concerns modifications to machines, e.g. other loading systems. If the digital twin reflects reality well, including timing parameters, different versions of the mechanics can be weighed against each other without the need to manufacture them.

The digital twin can also be used for training purposes, which is an additional benefit. This means that operating personnel can be trained on a virtual basis on the real control system in conjunction with the simulation.

In a machine showroom, machines or variants could be presented which, for whatever reason, are not currently available for display.

Digital twins with NUM controls

We offer two versions of digital twins for control purposes. On the one hand a mixture of software and hardware in the loop, on the other hand a classic Hardware in the Loop solution.

The first version includes a machine model in the integrated PLC of the Flexium+ control. This model is a stand-alone PLC program and uses predefined components that simulate individual machine elements, such as sensors, spindles, pneumatic cylinders, etc. The Flexium NCK executes the NC programs and simulates the position values of the machine axes. In order to understand the overall behavior well, it is helpful to visualize the process. The CODESYS Depictor is used for this purpose. This is used to model and animate the machine. The information for the model animation comes from the simulation program of the PLC and Flexium NCK.

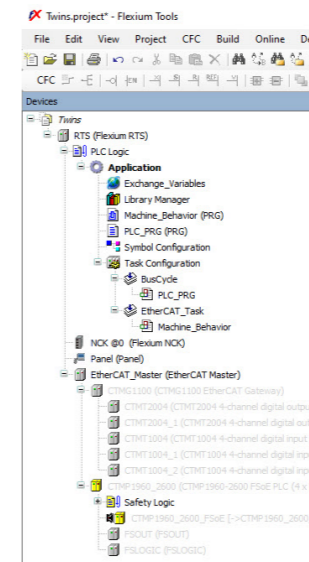

This form of digital twin requires:

- NUM iPC (e.g. FS154i)
- Flexium NCK
- Flexium Tools
- CODESYS Depictor

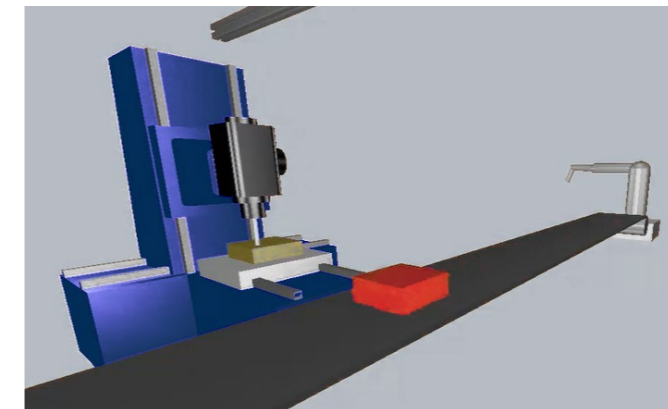

We also have a solution for a classic Hardware in the Loop twin. For this we use ISG-virtuos, which incorporates software that is specialized for real-time applications. This tool enables the testing, commissioning and optimization of automation systems with real controllers. ISG-virtuos replaces the machine with a PC and communicates via EtherCAT with the Flexium+ controller in real-time. The virtual machine is built from virtual components, which behave like the real components in terms of interfaces, parameters and operating modes. Thus, it corresponds in detail to the structure of the real system. The movements of the machine are displayed in a 3D simulation. The necessary information is exchanged between the twin and the Flexium+ controller via EtherCAT.



This form of digital twin requires:

- NUM iPC (for example, FS154i)
- Flexium NCK
- Flexium Tools
- PC
- ISG-virtuos
- Interface module in Flexium+ for connection with ISG-virtuos



Digital Twin Connection Flexium+

This virtual machine is used to simulate realistic test and commissioning situations including all control functions in the sequence (PLC) and motion control (CNC). These system tests can also be performed automatically. The functions developed and tested in this way are then simply transferred to the real systems.

Which of the two solutions to choose depends on various factors and is not always easy to resolve. Our engineers will be happy to assist you with their know-how in working out the decision criteria or even in the realization of the virtual machine.

Accelerometer solves vibration problems

More effective machining with new CNC functions

NUM Accelerometer

There are many companies supplying different types of very good and robust sensors, including accelerometers, to the market today. So why are NUM now proposing their own solution?

Most of the accelerometers currently available on the market are incapable of sampling at a high frequency rate; they typically need additional conditioning electronics before they can then be connected to a CNC/PLC system through a field bus that, in the best case, provides data every few milliseconds.

Can typical machine vibration be damped if the acceleration value is only available every few milliseconds?

The answer is typically no, it cannot. NUM has therefore decided to develop its own accelerometer, which can be directly connected to NUM's servo drives. Sampled at 100 microseconds, it can be used in closed loop control configurations with bandwidths up to some hundreds of hertz.

One of the most interesting applications is the following: the Tool Centre Point (TCP) of a machine tool is vibrating due to vibration modes of the machine's mechanical structure; even if the machine is equipped with a high-resolution encoder (integrated in the servo motor), it is not possible to damp the TCP vibration, as it is not measured. Complex system modeling and state space control could give some effective results, but the complexity is very high and the robustness of the compensation is quite weak (for example, in the case of a small parameter change, like inertia, the effectiveness of the compensation would be lost).

By measuring the TCP acceleration (for example, in each of the main X, Y and Z axis directions), with NUM accelerometers connected to NUM servo drives and using advanced functions like DEM-X (Drive Embedded Macro) and NUM's Active damping function, the TCP vibration can be accurately and robustly damped! An example is shown in the attached pictures.

In some cases precise linear scales are used. These allow NUM's active damping to be used to damp the kinematic chain vibrations, but they do not automatically mean that the TCP vibrations are also damped.

The above is just one of the many possible problems that can be addressed with NUM's accelerometer. The acceleration information can also be digitally and cyclically transmitted to the Flexium+ NCK and stored in the NCK ring buffer.

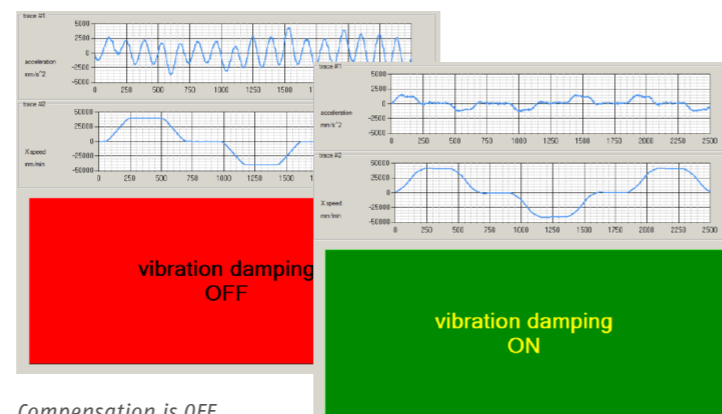

Compensation is OFF
Trace # 2: X axis speed
Trace #1: End point is vibrating at its natural frequency (about 3 Hz)

Compensation is ON, Trace # 2: X axis speed, Trace #1: End point is moving and the acceleration is just the programmed one (natural frequency completely compensated)

This information can then be cyclically uploaded to the Windows domain for further evaluation or for use with NUMmonitor.

The acceleration information can also be used for the following: to optimize the machining process (for example, to avoid chattering), to detect spindle vibration (bearing problems), to detect mechanical de-rating (friction / backlash), to detect and log machine crashes, to estimate tool life, to detect tool breakage etc.

NUM's accelerometer connected to a NUM Flexium+ CNC system can be used to address and solve many problems. Please get in contact with us, so we can support you in solving your issues.



New CNC Functions: Trochoidal Milling Cycle (G725) and Engraving Cycle (G730)

As part of its most recent software revision, NUM launched a set of different Flexium+ NCK cycles. They are related to more effective and faster part processing in milling applications, and include an essential extension for industrial engraving applications using letters, numbers and special characters.

FXS0000700 Trochoidal Milling Cycle (G725)

A Trochoidal/cycloidal motion is the curve that describes a point on the circumference of a circle when the circle moves along a straight line. Trochoidal milling is a specific strategy for milling that uses new CAM programming systems and control cycles to achieve consistent tool engagement, higher material removal, and a consistent average chip thickness. As a result, optimum and effective machining processes are guaranteed.

The most important customer advantages are:

- Decreased cutting forces
- Reduced heat
- Greater machining accuracy
- Improved tool life
- Faster cycle times
- One tool for multiple slot sizes

The Trochoidal Milling Cycle can be started with G725 in NUM ISO programming with different cycle parameters, including feed definition.

The syntax is very simple:
G725 EL.. [EF.] [EG..] [ES..] [EE..] ER.. EH.. H..N.. N.. Q..

Cycle parameter description:

EL..	Width of the Trochoidal machining
EF..	Machining feed
ES..	Feed ratio for the recovery path
ER..	Retraction plane in the tool axis
EH..	Height at which the machining starts
EG..	Clockwise (-1) or counterclockwise (1) motion
H..	File where the profile is programmed
N..N..	First and last block of the profile
Q..	Advancement path
EE..	If programmed 0, the finishing machining is performed

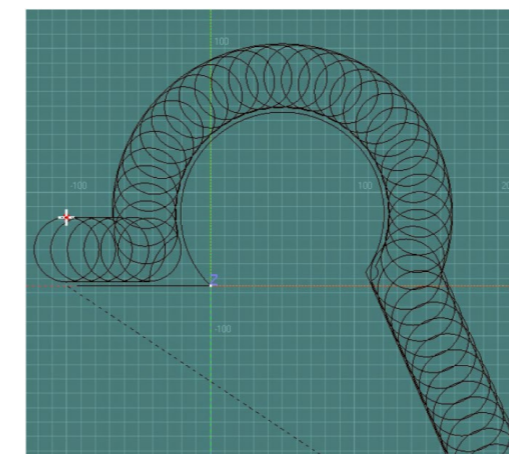

FXS0000700 Trochoidal Milling Cycle (G725)

FXS0000701 Engraving Cycle (G730)

The G730 cycle is used to engrave characters from a string of text by interpolating the axes in the machine. The symbols that are available are the uppercase and lowercase letters (A-Z and a-z), numbers from 0-9 and some special characters. It is possible to write text in a straight line, with an inclination, or along the circumference of a circle with a certain radius R. Each letter can also be rotated by an additional angle (inclined character). This engraving cycle allows the end user to write some text (such as an ID, serial numbers, piece coding or date and time) on the workpiece without using a CAD/CAM system or any other software tool.

The syntax is:
G730 X.. Y.. Z.. R.. EL.. EA.. EI.. ER.. EH.. EX.. F..

The G730 engraving cycle has a full set of parameters to determine the position, layout and pattern of the text.

X..	X position of the SE (southeast, lower left) corner of the rectangle including the first letter
Y..	Y position of the SE (southeast, lower left) corner of the rectangle including the first letter
Z..	Z position of the engraving end (depth)
EL..	Height of the letters
F..	Machining feed
ER..	Retraction plane in the tool axis
EH..	Height at which the machining starts and all movements made between letters
R..	Radius of the circle on top of which the text is engraved
EA..	Angle of inclination of the text if straight line or angle of start in a circle
EI..	Space between characters (interspace)
EX..	Additional rotation of each character
EP..	Axial path

The most remarkable aspect of these new functions is that they both take the form of user-defined G cycle commands. This not only provides more flexibility, but also shows the performance of G functions for these types of applications. Of course, Flexium+ CNC has the necessary computing power for an integrated function, but a user-defined G function is just as efficient as an integrated one and offers in addition more customization options. Further information on G725 and G730 or other user-defined G functions can be found in the Flexium+ documentation or it can be obtained from your NUM NTC contact person, who will be happy to provide you with suggestions and solution support.

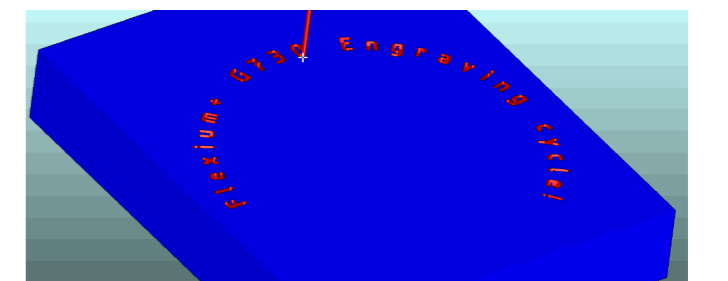

FXS0000701 Engraving Cycle (G730)

Protecting your know-how

Compensating for geometric errors

Protect your know-how

Good machines are characterized by one or more unique selling propositions (USPs), which differentiate them from the competition and help support marketing. These USPs can be of a very different nature, although today they are very often realized by software functions or a combination of different disciplines. A USP and the know-how needed for this USP should be protected as much as possible. It can certainly pay to be a little paranoid at this point. It is important that competing machines cannot incorporate the USP simply by copying it. Since many of today's USPs involve software, appropriate protection mechanisms are increasingly needed on the various systems. There are of course also other reasons to protect software, such as guarding against unintentional changes or for safety reasons, as for example with the Safety PLC.

The Flexium+ system offers various options for know-how protection. The system can be roughly divided into three areas: PLC, CNC/drives and HMI or software running on the PC. In each area, functions can be protected against unauthorized access and unauthorized copying.

SPS

Let's start with the PLC and protection against accidental changes. Flexium Tools offers the opportunity to open a project in read-only mode, or in the project itself you can define that it can only be opened in read-only mode.

The actual copy protection or know-how protection is achieved by encrypting the project file. This is done either with a project password, with the help of the CODESYS security key (dongle), or with the help of a certificate. If only a certain module of the PLC is to be protected, which has servicing advantages, it is possible to work with protected libraries. The library file on the PLC no longer contains source code, but only an encrypted precompiled code.

To keep future service operations simple, the source code of the PLC project should always be available on the PLC, whether unencrypted, with encrypted libraries or fully encrypted.

CNC/Drives

At the CNC/drive level, Flexium+ offers the option of storing and executing CNC programs (M and G functions, subroutines, macro programs and real-time programs) in a protected manner. For this purpose, the programs are loaded into special memory zones of the control and, if desired, encrypted with a password. When protecting the programs, it is possible to determine whether or not the program code is displayed during program execution. If a backup is made by the controller, these programs are only loaded from the controller in encrypted form. To prevent these special programs from running unauthorized on other NUM controllers, the program

code can be linked to the serial number of the controller. This allows the program to be executed exclusively on this controller. If, on the other hand, a program is to be released for a certain machine type or optionally for several machines, this can be done by querying option bits. The option bits are contained in a license file which is encrypted together with the license hard lock of the CNC.

HMI/Software

As in the rest of the system, the standard user interface running on the PC is for the most part not protected. If specially developed parts of the user interface or other software modules running on the PC are to be protected, various methods are used, depending on the actual aim of the protection. Technology HMIs developed using Flexium CAM can be password protected and encrypted. If other HMI parts or software are to be protected, the machine manufacturer can use protection mechanisms that they already have in place for such cases. If the machine manufacturer has no preference, our engineers will of course be happy to analyze the protection mechanisms for the respective application and make a concrete proposal. Due to the scalable, open CNC system, software parts running on the PC can also be linked and encoded with option bits used in the actual CNC.



The protection of know-how and thus the encryption of software is becoming increasingly important. It is certainly not wrong to have a few thoughts on this topic. Our engineers are happy to assist you with their broad knowledge.

Compensation of squareness and misalignment errors between axes

A critical aspect of machine tool geometry is the squareness between the axes. Two orthogonal axes (moving tables, slides) are not mounted exactly at 90° to each other. The directions of movement along the axes of a machine-tool can be skewed by geometrical deviations inherent in the manufacture and assembly of components.

Squareness errors are often caused by mechanical bending or by misalignment during assembly of the parts or by machined surfaces of fixed parts that are not perfectly square, or by the relative positioning of several parts, which is not rigorous. The ISO-230 standard has defined location errors (i.e. positioning and orientation errors), described by constant and signed values, from which squareness and misalignment errors between axes can be easily modelled.

Location errors: Geometrical errors associated with a straight reference line

A sliding element allows a body to move in a spatial direction. In ISO 230-1, the direction of movement in a three-dimensional space is defined by two orientation parameters and a zero point parameter.

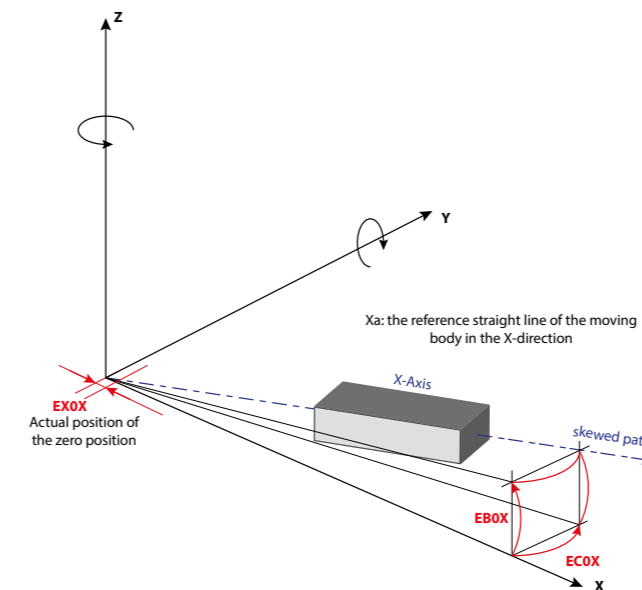

Fig.1 Location errors for a linear axis (X-axis)

- The figure 1 shows the location errors for a X-axis where
- EBoX is the orientation error of the X-axis around the Y direction; Measuring the perpendicularity of X with respect to the Z-axis;
 - ECoX is the orientation error of the X-axis around the Z-direction; measuring the perpendicularity of X with respect to the Y-axis;
 - EXoX: zero position error of the X-axis.

Location errors applied to a 3-axis machine wXYZt

By successive assembly of the kinematic elements of the machine structure, we insert, in the modeling, the reference line of each axis, represented by their direction with two orientations, built one with respect to the other.

Figure 2 illustrates the set of position errors of a 3-axis machine where the reference line of the first axis coincides with the X axis, and where

- EAoY and ECoY represent respectively the orientation error of the Y-axis around the X-axis direction and Z-axis direction
- EAoZ and EBoZ is the orientation error of the Z-axis around the X-axis direction and Y-axis direction.

The zero positioning errors of the axes have been overlooked.

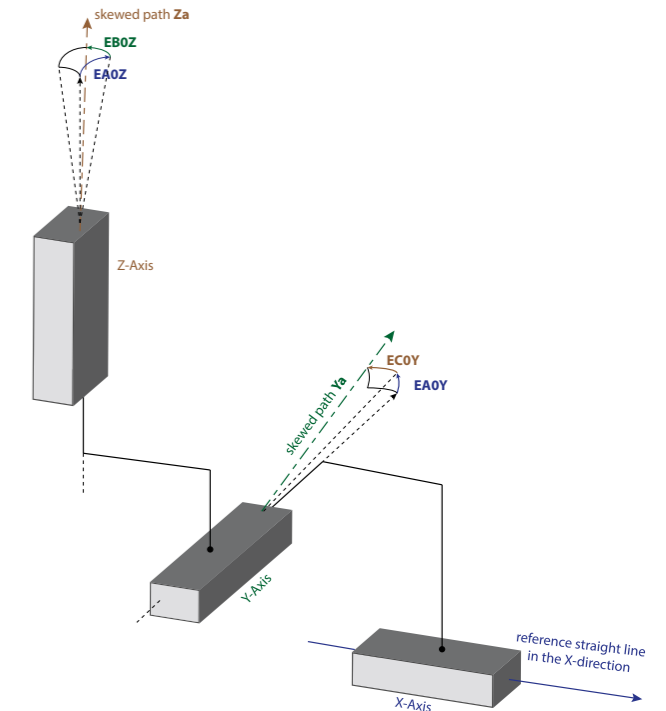

Fig.2 A set of orientation errors linked to an 3-axis machine wXYZt and used for a compensation of squareness

How to correct such squareness errors?

To compensate such errors there are two possible solutions: correct the machine's mechanics with expensive and time-consuming reworking, or measure such errors and correct them, in real time, inside the Flexium+ CNC system.

Till now Flexium+ CNC system provided the possibility to compensate some squareness errors, and much more, by the VECOMP (Volumetric Error Compensation) option. Starting from the next major software release an easy to use standard function for the compensation of squareness errors will be available! This new function will support up to 5 axes machines including machines with a gantry. This means that, for example on a gantry machine, an even not exact mounted rotary table can be compensated in a simple way. In case the compensation of squareness errors is not sufficient, but the full volumetric compensation is needed (to compensate for deviations such as vertical and horizontal straightness or angular errors such as rolling, pitching and yawing), the VECOMP option offers the solution. Roll-pitch-yaw angles are special Euler angles (orientation angles) which are used to describe the orientation in three-dimensional space.

Revoc provides specialist retrofitting of Kellenberger cylindrical grinding machines



Revoc AG in Romanshorn on Lake Constance (Switzerland) is a proven specialist for general overhauls, repairs, and service work on Kellenberger cylindrical grinding machines. Founded in 1996, the company is now well established in the market. The managing directors Roland Brüllmann and Thomas Zeller know Kellenberger cylindrical grinding machines down to the last detail. Both previously worked for several decades directly for the machine manufacturer, in the areas of customer service, sales and training.

Revoc AG replaces the complete electrical installation, including the entire CNC control system, when retrofitting a Kellenberger machine. In close cooperation with NUM AG, the work entails fitting a new electrical cabinet with matching paint, new CNC control, new AC servo axis drives and new positioning systems. The machine is functionally – geometrically as well as optically – as good as new after a complete retrofit. Each machine is geometrically accepted in accordance with the original Kellenberger inspection reports. For the complete overhaul of a Kellenberger CNC cylindrical grinding machine, a rough estimate is 12 weeks. Revoc is currently able to carry out 10–12 such retrofits per year. The capacity can of course be adjusted upwards as demand increases.

Fast infeed of the grinding wheel thanks to GAP sensor
The control system used is a NUM Flexium+ 8 with the NUMgrind software package for cylindrical grinding. The axes are moved by two NUM BPX126 motors and one BPG142 motor. A GAP (Grinding Analysis Process) sensor from Elaso AG is connected to the NUM controller, which bridges the 'air grinding'. The sensor's output is completely integrated into the HMI of the control unit and is graphically displayed on the screen, so that the user can also use this signal for other activities such as starting the dressing diamond or calibrating the wheel during set-up.

True to the motto: times change, but quality does not
Kellenberger machines enjoy a good reputation and it is not surprising that retrofitting has met with lively customer interest as an attractive and sustainable solution for maintaining these machines and extending their operating life. The retrofit presented here refers to a Kellenberger type UR 175X1000 CNC universal cylindrical grinding machine (featuring 175 mm center height at 1,000 mm maximum workpiece length). This modernization also marks the foundation stone for the first cooperation between Revoc and NUM.

Effective cooperation Revoc and NUM
Our sample machine was delivered to the customer in 1992 and since then has only undergone regular servicing. After 28 years the first overhaul is now due. The basic functions as well as the mechanics will be retained in this case. The retrofit starts with dismantling by Revoc's specialists. The machine stand and other machine parts are sandblasted and repainted according to customer requirements. Depending on their condition, between 300 and 500 individual parts must be overhauled or reworked. Even in the case of a retrofit, the currently valid regulations for machine tools, such as CE conformity, must be fulfilled. This includes a CE-compliant electrical cabinet, a safety solution and a monitored splash guard. CEO Roland Brüllmann comments: "Together with the renowned control company NUM, we have worked out a concept to replace the complete CNC control as well as the electrical installation. The machine was commissioned together with NUM and the process went absolutely perfectly." Thomas Zeller adds, "I appreciated the collegial basis of the cooperation, as well as always receiving quick and competent answers from NUM. The mutual communication went very well."

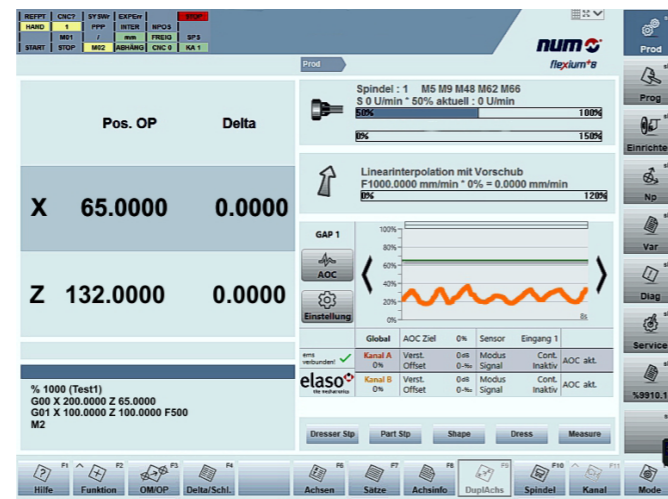

NUM Flexium+ 8 control with GAP sensor integration

Grinding cycles

The NUMgrind software package offers specific grinding and dressing cycles for cylindrical grinding for internal and external machining. No DIN-ISO knowledge is required for programming the control. The operator is guided through the programming process by the graphical user interface. A wheel data management function with various wheel shapes for eight stored configurations facilitates the fast creation of grinding programs. Additional grinding functions such as an interactive intermediate dressing in the automatic process, an emergency retraction or the correction of a concity error are available to the operator. Longitudinal measuring devices as well as in-process measuring systems for diameter monitoring are optionally available.



Revised Kellenberger UR 175X1000 machine from 2020



Kellenberger UR 175X1000 machine from 1992

All-round carefree package

In addition to machine modernization, Revoc naturally also offers all other necessary services. For example, the entire delivery and transport process, machine commissioning, training of machine operators, and many more. Once the modernized machine is back in operation, it also needs servicing or, if necessary, extensions. Revoc offers these services both nationally and internationally, according to customer requirements. Revoc serves all companies across all industries in which Kellenberger cylindrical grinding machines are used. Revoc supports one-man operations as well as larger companies in the mold- and tool-making industry with the same range of services.

A total package that is worthwhile!



From right to left: Mr. Thomas Zeller, Deputy Managing Director Revoc, with Mr. Roland Brüllmann, Managing Director Revoc and Mr. Kurt Plüss, Area Sales Manager of NUM

Successful retrofit for a new life of a Walter Power with NUMROTOplus



The managing director and owner, Mr. Swen Hagelstein, runs his steadily growing company, SOS Elektronik, in Wasserburg at Lake Constance (Germany). The company specializes in bringing old machine tools up to date and making them safe to operate. On the one hand this is to save resources and on the other hand to enable further, long lasting use of the machine. Hagelstein's experienced and international team overhauls old machines, replaces the CNC controls and brings the power electronics up to the state of the art. The team brings the machines back to life. The retrofit can be performed either at SOS Elektronik's facility in Wasserburg or directly on-site at customers' premises.

The retrofit solutions provided by SOS Elektronik are proving a great success. The company offers general overhauls of various machine models, including the Walter Power, the Hawemat 2000 and 3000, and the Schmitt Tempo ETC 502. From the original business idea of worldwide field service for Walter CNC grinding machines, the range of products was quickly expanded thanks to increased demand. It should be emphasized that SOS Elektronik works completely independently and autonomously.

Ready for use again in one-third of the time

In order to conserve resources and save energy and time, SOS Elektronik generally prefers to perform on-site conversion. The preparation of the retrofit takes place at SOS Elektronik, including a preliminary test of the parts to be replaced, after which everything is done at the customer's site at the machine location. Due to the duration of use of the machines, the machines to be overhauled are often located at the back of production halls, in difficult to access areas. Dismantling and transport usually entails longer downtimes, loss of sales and high transport and customs costs. On-site conversion also avoids customs problems, reduces waiting times and usually no replacement or rental machine is required. With on-site conversion, the machine is ready for use again three times faster than would be the case with dismantling and transport.

Managing Director Mr. Swen Hagelstein talks about the core of the retrofit philosophy: "The machine must be able to do again what it was able to do before, and hopefully a little bit more over the years." Mr. Hagelstein adds: "I always like to compare it to an old car: the customer has an old 55 hp Golf 2, and wants to keep it. But the engine and transmission are on their last legs. SOS Elektronik installs an engine of this size for him again. That means he has 55 hp again, and still drives a Golf 2. But the car now has some important additional advantages: the new engine is more economical, safer, more environmentally friendly and runs more quietly, even though it remains a Golf 2."

Convinced by the cooperation

Hagelstein's professional background is CNC control engineering. Exactly for this reason it was of central importance to him to integrate tool grinding software which is widely established in the market and regarded as standard application software by the industry. After identifying the first projects and interested parties, SOS Elektronik collaborated with NUM to ascertain the best way of breathing new life into the machines. Besides the well-known NUM

Flexium+ CNC system, the established NUMROTOplus® application software is used in the 'old' machines. NUMROTO is a comprehensive software package for the production and sharpening of various tools that has been available for over 30 years. Nowadays, the software is regarded as a trendsetter and is also the market leader in tool grinding – worldwide. Innovative high-tech solutions, flexible and versatile application possibilities, continuous development and comprehensive user know-how have always guaranteed quality and economy for all standard and special tools.



Managing Director SOS Elektronik, Mr. Swen Hagelstein, with Area Sales Manager NUM Switzerland, Mr. Ralph Jacobs

As Area Sales Manager of NUM Switzerland, Ralph Jacobs, comments: "Two parallel worlds have found each other here and complement each other perfectly. The physical proximity of SOS and NUM means that many things can be implemented quickly, but the mutual gain in know-how is also remarkable." A good and solid basis for cooperation was thus quickly established. The first retrofit of a used power regrinder to a NUM CNC control system was implemented and successfully put into operation within a short time. According to Jacobs, the first grinding tests on this reconditioned Power Machine have already shown remarkable results. The complete rebuild to the new NUM CNC control package uses the latest NUM safety architecture and therefore the machine complies with today's safety regulations. In addition to the installation of the NUM CNC and NUMROTO software, the Power Machine has been considerably expanded in its range of functions and performance by the additional installation of tool and disk probes, and optimized for future applications.

With the future in mind

In times when sustainability is of great importance and trendsetting for the coming generations, SOS Elektronik focuses on the appropriate business field. The machines are given a second life and the production at the end customer's premises can continue as usual or even be increased. Initially, the widely used Walter Power Regrinder series was revised. In the future, however, retrofits for the Walter Classic and Mini series, as well as an optional loader or robot system, are also planned. Extending the service life for additional years by retrofitting an existing machine makes economic sense, especially in today's competitive markets, where production costs are becoming increasingly important.



Extended NUMROTO function: Disc probe



Finish ground special tool



Keys of important tool sizes

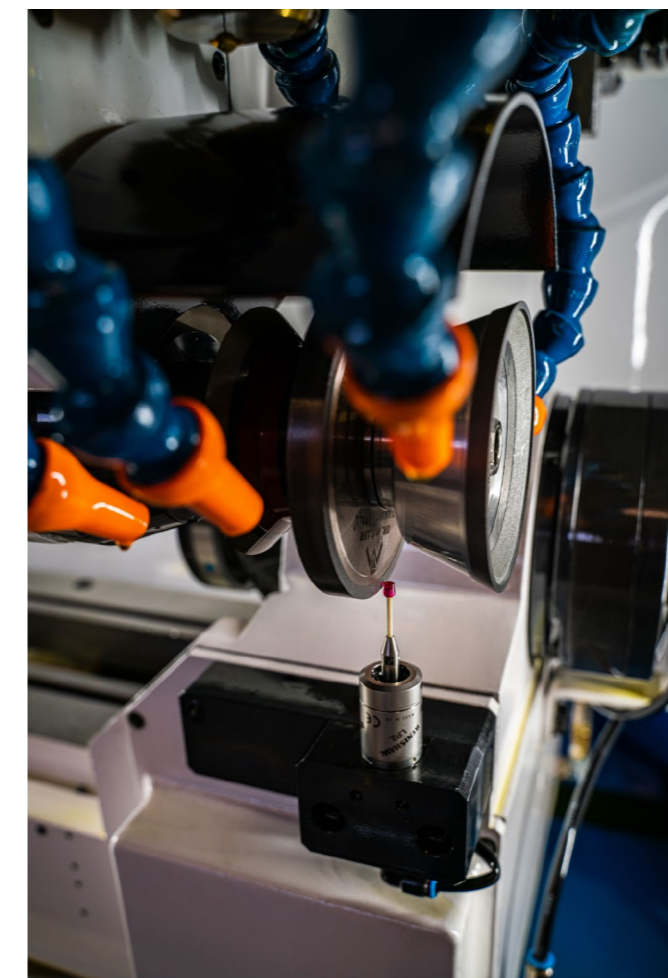

Extended NUMROTO function: Disc probe

CNC upgrade program provides US cutting tool manufacturer with major productivity advantage



32-year-old insert grinders given new lease of life – and production times now reduced by 10 minutes per part. US cutting tool manufacturer McQuade Industries, Inc., has gained a highly cost-effective productivity advantage by implementing a CNC upgrade program for a line of 5-axis insert grinders. The upgraded machines are much easier to set up and operate, which has enabled the company to shave more than ten minutes per part off the production time of complex geometric cutting tools.

Founded in 1978, McQuade Industries has built an enviable reputation in the metal cutting industry for the very high quality of its precision indexable cutting tools. Based in Clinton Township, Michigan, the company produces a diverse range of cutting tools, including boring bars, milling cutters, generating heads, draw bar style tooling and cartridges, as well as complete turnkey tooling packages. It also provides customers with fast turnaround tool regrinding and repair services, backed by extensive expertise in special carbide and precision form inserts.

The machines that are being upgraded are RS-12 insert grinders, originally manufactured by Ewag AG in Switzerland. McQuade installed a number of these highly regarded precision grinders back in 1988, and over the years they have provided stalwart performance. However, as McQuade's Production Manager, Donald Ostgen, explains, "After 30-plus years, even the best machines can begin to show signs of their age! Although still in good mechanical order, the grinders' control systems were beginning to lack the flexibility we needed for some of today's more complex tool geometries, leading to lengthy set-up and machining times."

Aside from the fact that the insert grinders still represent a valuable asset, McQuade had developed a large number of part programs over the years, which ideally would need to run on any replacement machines without requiring modification. The company therefore decided to preserve its investment by implementing a program to upgrade the machines' CNC systems, and subsequently engaged the services of Advanced Machine Technologies, LLC., a specialist CNC retrofit company based in Owosso, Michigan.



Before Retrofit

The original RS-12 insert grinders were fitted with NUM 760 CNC systems, NUM Güttinger NGS 610 servo drives and NUM/SEM brushed servomotors.

Having partnered with NUM on numerous automation upgrade projects over the past 22 years, Advanced Machine Technologies has considerable experience in replacing legacy systems such as these. In this instance, the company recommended upgrading to NUM's latest-generation Flexium+ 68 CNC system, and replacing the drives and motors on all five axes with NUMDrive X digital servo drives and new NUM brushless servomotors.

By transitioning to NUM's Flexium+ CNC platform, McQuade would secure full grind cycle flexibility while continuing to use a familiar HMI (human-machine interface) and machine setup operations. This upgrade path also provides full backwards compatibility with part programs that the company had made over the last thirty years.

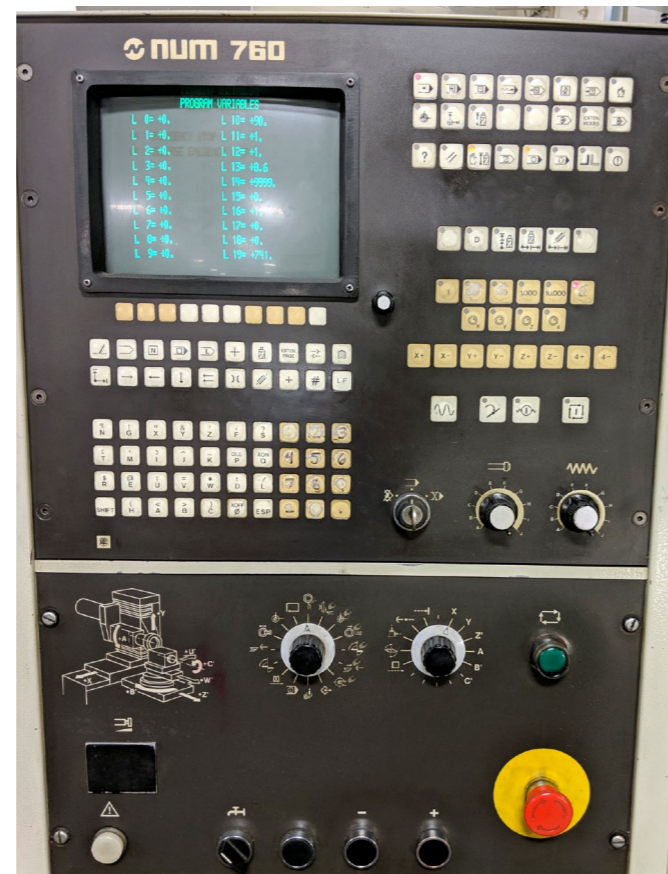

Furthermore, the embedded PC in Flexium+ represents a flexible IIoT platform that is Industry 4.0 ready, offering McQuade powerful connectivity advantages for future productivity enhancements and enabling NUM or Advanced Machine Technologies to provide remote support services if required.

McQuade sanctioned the work, requesting that Advanced Machine Technologies initially upgraded a single machine so that its performance could be evaluated before progressing further. As part of the upgrade, in addition to the CNC system, drives and motors, the insert grinder was fitted with a new NUM F5122 touch-sensi-



After Retrofit

tive operator's panel, an MP08 machine panel, and an HBA series portable hand-wheel. The variable frequency drive for the existing grinding spindle motor was also replaced, using a smaller footprint NUMDrive X servo drive to fulfill the role. This approach has the advantage that all command, feedback and status information is now exchanged over a fast digital bus, which simplifies wiring and improves diagnostic capabilities.

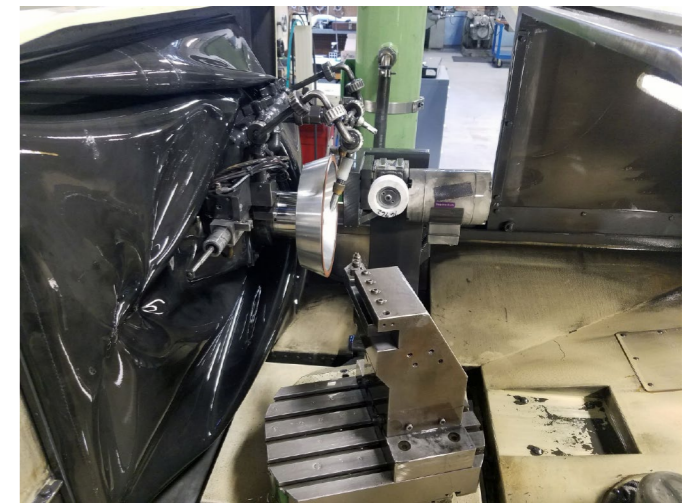

The upgrade has proved a resounding success. The move to all-digital drives and motors has significantly increased the overall speed and performance of the machine, resulting in faster grind feed rates and improved surface finishing. Donald Ostgen is extremely pleased with the level of service provided by Advanced Machine Technologies, and with the insert grinder's rejuvenated capabilities. "If anyone doubts the benefits of a CNC upgrade, they should take a look at our installation. The quality of workmanship is superb, the grinder is now much easier to program and the handheld pendant really helps simplify the operation. We are able to run parts on this machine that we could previously only run on our wire EDM (electrical discharge machining) machines, and its increased flexibility means that we are now saving over 10 minutes per part compared to the pre-retrofit model."

The first upgraded RS-12 insert grinder is now in full operation on McQuade's production line, and the company has already commenced upgrading the next machine on the line.



High speed laser cutting machine uses novel CNC techniques to accelerate throughput



CNC specialist NUM is helping Grupo Plasma Automation – one of Latin America’s top fabrication equipment manufacturers – to develop an innovative high speed laser cutting machine that uses real-time adaptive height control to accelerate throughput.

Grupo Plasma Automation comprises eight companies that specialize in the design and manufacture of fabrication automation. The group produces a broad range of plasma, laser and water jet cutting machines. Founded in 1991, GPA has grown steadily over the years and has built up a large and prestigious customer base; it has more than 700 cutting systems installed at companies in Mexico alone, and nowadays serves both the domestic and international markets.

GPA’s latest CNC laser cutting machine is designed to provide sheet metal fabricators with an ultra-flexible precision cutting solution. Branded SPEED CUT, the machine is capable of cutting a wide variety of metals with different densities, including galvanized iron, aluminum, brass, stainless and carbon steel. It has a work area of 1.5 x 3 meters and a maximum cutting speed of 120 meters per minute, with 40 microns positioning accuracy. The system delivers extremely smooth operation even at high speeds.

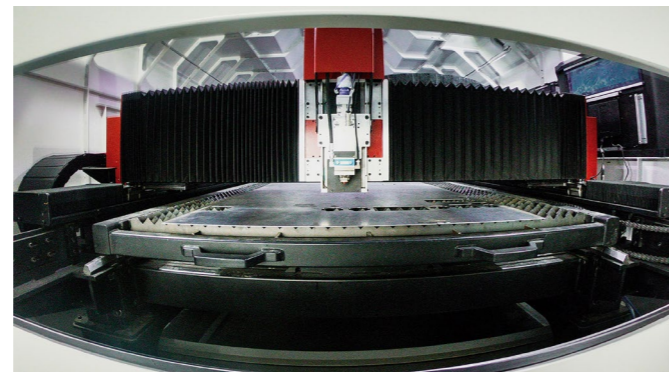

All cutting head positioning functions on the machine are controlled by a NUM Flexium+ 8 CNC system. According to Omar Sandoval, Owner and CEO of GPA, “We chose to partner with NUM mainly because of its open architecture CNC platform and NUM’s willingness to actively participate in joint development projects such as this.”

All four machine axes are driven by NUM high torque BPX servo-motors controlled by NUMDrive X digital servo drives; the Y1 and Y2 gantry axes are equipped with powerful 9.8 Nm motors, while the X and Z axes have smaller 2.7 Nm and 1.4 Nm motors, respectively. NUM’s Flexium Tool commissioning software allows the Y1/Y2 axes to

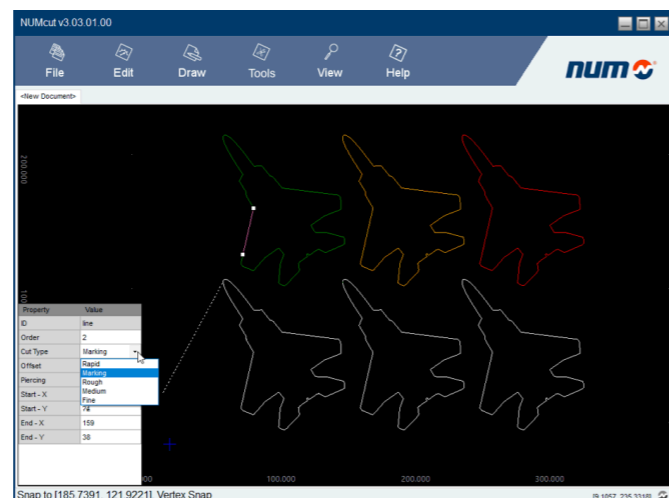

To help maximize performance and reliability, GPA’s new cutting machine is based entirely on industry-leading laser and control technology. The laser source is a 2 kW IPG Photonics’ solid state ytterbium fiber system, with a wavelength of 1.07 micrometers, while the cutting head is a Precitec LightCutter 2.0 unit. This particular cutting head is renowned for its dynamic performance – it features automated motor-driven adjustment of the axial focus position, can handle acceleration rates as high as 3 g, and covers a large focus position range of 23 mm.

be tuned while the synchronization is active, which provides a very powerful means of maximizing performance and precision.

The Z axis controls the vertical height of the laser cutting head above the sheet of metal that is being cut. By capitalizing on the unique ‘Dynamic Operator’ (DO) function in NUM’s Flexium software – which enables event-driven machine cycles to be integrated into the real-time CNC kernel – the user of the speed cut machine benefits from an automated dynamic height control system that accommodates extremely fast cutting speeds. The system interprets data from the machine’s cutting head height sensor and uses it to very quickly adjust proportional-integral-derivative (PID) loop parameters in the Z axis servo. The height sensor is also employed to facilitate an automatic sheet detection routine: this determines the workpiece’s dimensions, zero, and angular offset, further simplifying the machine’s operation.

Steven Schilling, Managing Director of NUM Corporation in Naperville, Illinois, points out, “We are delighted to be collaborating with GPA in the development of this new machine. In addition to the real-time adaptive height control and sheet detection systems, the customized version of NUMcut software that we are providing features a user library of material cutting conditions. It is preloaded by GPA with the optimal laser power levels, cutting speeds, etc., as a function of material type and thickness. The provision of this library will further add to the machine’s productivity and cutting accuracy.”

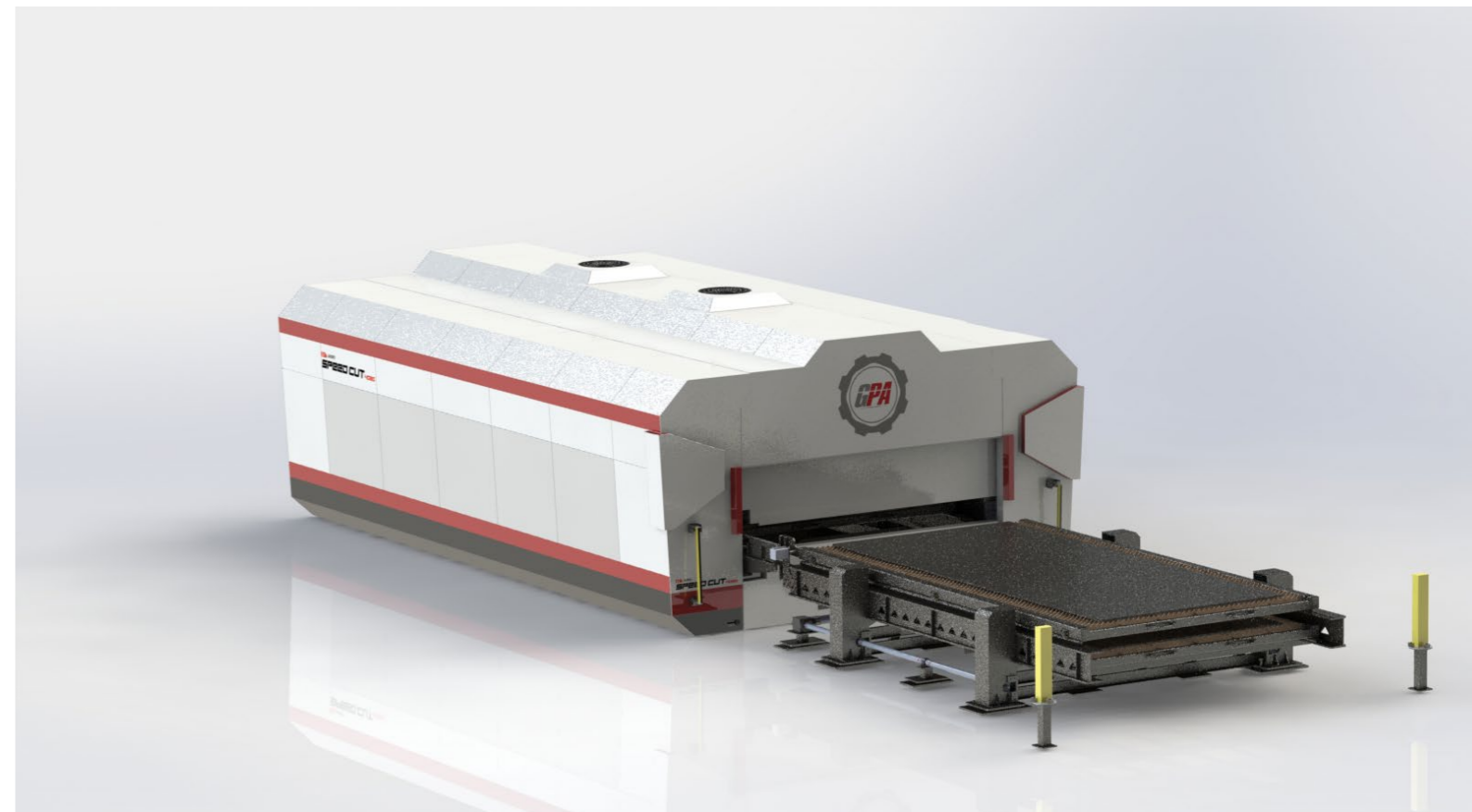
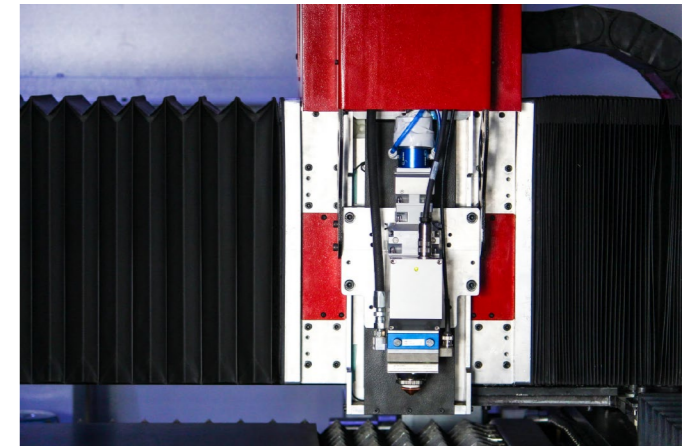

Flexium+: Performance and durability



Overview of the machine with its two working areas

NUM's desire to offer high-performance, long-lasting and compatible products over time is a win-win solution for users and manufacturers alike. The situation described below is a perfect illustration of this.

Located in La Bussière in the Loiret, France, APTE designs and manufactures thermoplastic parts for the automotive, medical, aeronautical and other industries.

These parts, which can reach dimensions of more than two meters, are made of different materials, from classic ABS to the latest complex soft touch materials intended, for example, for car interiors. Whatever the material, forming is only part of the process. After this operation, the parts have to be machined for deburring, drilling and various cutouts. During these operations, the stresses associated with hot forming will be released and the parts can undergo deformation, which, although minimal and reproducible, is difficult to estimate beforehand. For this reason, it is essential to be able to adapt the machining programs quickly and as simply as possible.

When Mr. Zedda, APTE's CEO, decided to increase his machine park to keep pace with the company's growth, it was clear that the control system would have to be supplied by NUM for the reasons mentioned above as well as for the sake of consistency with the existing park, which was giving full satisfaction. For the machine, Mécanuméric was called upon, whose Normaprofil T series model met the desired requirements and was already part of the APTE fleet.

Mécanuméric, located in Albi, in the South-West of France, specializes in cutting equipment for milling as well as water jet, laser, ultrasonic and other innovative techniques. With several tens of thousands of machines installed throughout the world, its clientele is spread over the industrial, dental and educational fields. Although his company does not have recent experience of NUM equipment and in particular, of the proposed Flexium+ system, Mr. Païs, its director, accepted the challenge, having full confidence in the ability of his services to conclude this project. The technical teams from Mécanuméric and NUM therefore immediately got together to create the optimum solution. After providing initial training, NUM provided technical support to answer questions as they arose, with on-site assistance for very specific operations such as adapting drive parameters to particular motors, including the machine's 24000 rpm electro-spindle. The cooperation proved to be very efficient and Mécanuméric was able to develop the whole application – including the entire safety part, which is fundamental on this machine as it has two working areas. The support of NUM has always been present as confirmed by Mr. Païs, who indicated his satisfaction with the excellent involvement of the two teams.

As far as the machine is concerned, it is a 5-axis deflashing machine with gantry and RTCP. It has two work areas that are secured so that it can work in pendulum mode in complete safety. Each zone has its own tool changer located on the right and left sides of

the frame, which can be shared if necessary and if safety permits. The positional axes are based on NUM's SPX series motors, which are characterized by a single cable that transfers both power and measurement signals, thus simplifying connections and minimizing moving mass. The NUMDrive X single or dual-axis drives are of course equipped with the SAMX safety function to ensure safe operation. The EtherCAT bus I/O package includes an MP06 machine control panel as well as around 30 standard or safety terminal modules, including the safety PLC itself and an I/O-Link terminal for the direct connection of sensors and actuators.

An important element for the success of an automation project is the tool or set of tools that will be used. In this respect, Flexium+ requires only one software workshop: Flexium Tools. This software suite runs under the Windows operating system and allows complete development of a machine – from the initial description of its structure through to maintenance of the completed control programs. Parameter setting of the numerical control and drives is achieved using graphic editors, which can be supported by text editors to deal with the very specific cases of certain special machines. The PLC program can be written in one of the five languages of the 61131-3 standard, while the safety PLC is configured using approved function blocks. These programs can be debugged and tuned using the same interfaces, with different priority levels that can be assigned to different user groups to prevent unwanted changes. In addition, Flexium Tools allows the definition and control of graphical visualization pages that can be integrated into the standard HMI for diagnosis or machine control.

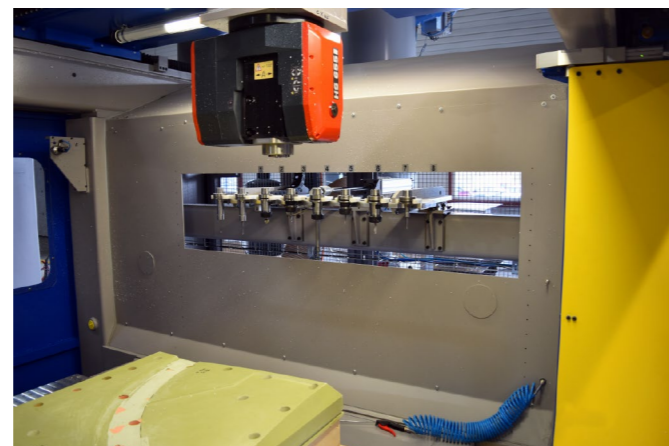

Details of the RTCP head and the right changer

This powerful and easy to implement functionality has been widely used in this project, as can be seen in the screenshot example. Finally, Flexium Tools features integrated software 'instruments' such as time or frequency oscilloscopes, ball bar functions, etc., which simplify drive adjustment and facilitate checking the stability of settings.

This partnership once again highlights NUM's strengths and the benefits you can get from working with the company. Flexium+ solutions cover the entire range of CNC requirements with modern, powerful CPUs, powerful and highly adaptable software, a wide range of I/O peripherals and user-friendly user interfaces. As Mr. Barsanti, Managing Director of NUM France, explains, "NUM's objective is to offer a modern, high-performance, flexible solution that will remain operational, at a reasonable cost, for many years to come, as is the case for the different generations of APTE's fleet." He adds, "APTE's choice allows NUM to reap the rewards of the quality of our work over the long term." Nevertheless, pure technology is not the only component of a successful project and we would like to highlight the quality of the partnership. Our commercial and technical teams are at your disposal to promote all of your competitive advantages and allow you to develop them. Mr. Zedda, APTE's Chairman and CEO, confirms this: "We are very happy to have asked Mécanuméric to provide us with a machine equipped with NUM's CNC and are particularly satisfied with the cooperation between these two companies."

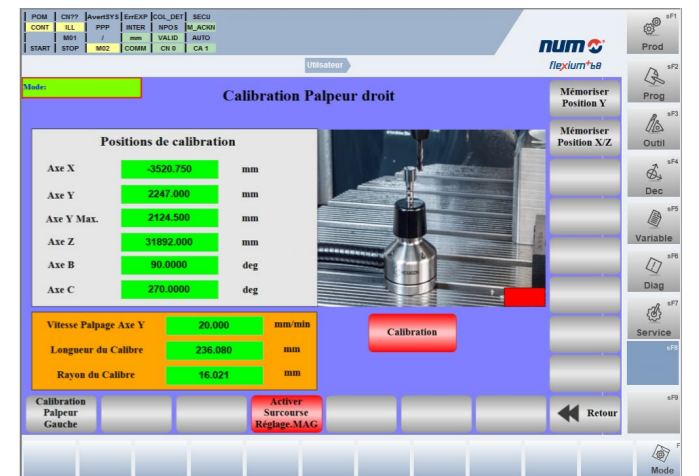

An example of a custom HMI page: Probe Calibration



From right to left M. Gassot FAO Production Manager of APTE and M. Barsanti Director of NUM France

Own grinding software know-how combined with the NUMROTO infrastructure



In Zell am Harmersbach (Germany), in the beautiful Black Forest, you will find Prototyp-Werke GmbH, a production site of Walter AG. Since 2007, Prototyp-Werke has been integrated into Walter as the competence brand "Walter Prototyp" in the field of threading and milling tools. Walter celebrated its 100th anniversary in 2019. The company was originally founded by Richard Walter in Düsseldorf, where sintered carbide alloys and new metallurgical processes were researched. Nowadays, the threading and milling tools are manufactured in a plant with a production area of some 8,000 m² that employs approximately 450 people, working shifts.

Other significant brands of the Walter Group are "Walter Titec" (drilling tools), "Walter Multiply" (digital solutions, tool management, training and production process planning) and "Walter" (carbide inserts, tool systems for milling, insert drilling, turning and grooving). References to these can be found as vertical elements in the Walter logo, "Yellow" stands for the Walter Prototyp competence brand. Walter employs about 3,500 people worldwide. The company is headquartered in Tübingen, south of Stuttgart. Customers in over 80 countries are served and supported by numerous subsidiaries and sales partners. The focus is on the automotive industries, rail industries, aerospace, the energy sector and general mechanical engineering.

The production department in Zell am Harmersbach and NUM have collaborated successfully for almost three decades. Proof of this is, among other things, the customer report from 1993 on NUMROTO with the significant title "Farewell to black art", attached below.

Mr. Martin Marx, software developer TEWL, has been in the service of Prototyp-Werke since 1982. He was present at the 1993 report, as was Mr. Jörg Federer from NUM. The two men have therefore enjoyed a long and fruitful business relationship.

The Walter production site in the Black Forest has acquired comprehensive know-how in tool grinding over the last decades. For many years, a proprietary software development has been used on tool grinding machines equipped with NUM controls, in parallel with NUMROTO, enabling many complex tool shapes to be realized for customers. With a hundred years of company history, it is therefore not surprising that the internal transfer of knowledge is

of central importance and must be ensured. This is where NUMROTO comes into its own. Thanks to the "External Calculation" function, the company's own algorithms and path calculations, and thus their know-how, can be integrated and merged with the comprehensive NUMROTO software solution.

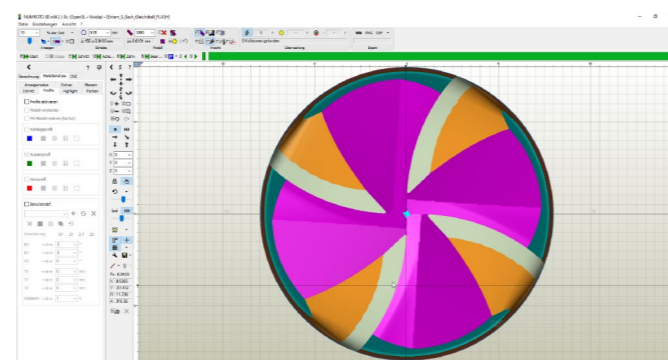
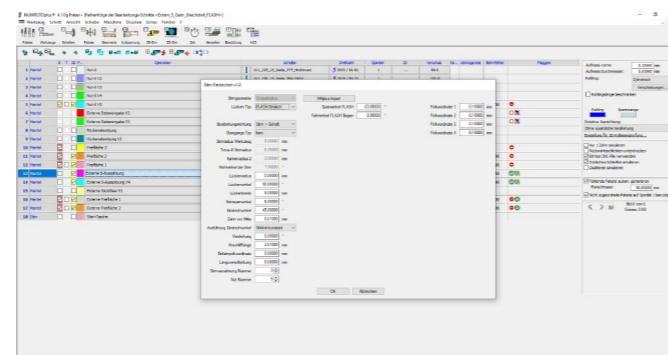

Screenshots External calculation within the NUMROTOplus® user interface

Prototyp uses a large part of the NUMROTO infrastructure, including the high-precision and comprehensive 3D simulation, post-processor (machine-specific calculation of the 5-axis path), database, wheel management, multi-language support and also the X-machining. Prototyp's path calculations are integrated into NUMROTO as "external calculations." Since the company only uses its own path calculations internally, they are not accessible to other customers – and thus the know-how of the tool manufacturer is protected! This flexible concept allows the knowledge built up by the internal development team to be passed on and also further developed across generations, while the remaining infrastructure of the programming system is maintained and transferred into the future by NUMROTO. "The external computation feature allows us to produce tools that NUMROTO does not offer as standard", reports Martin Marx, and adds: "the proven NUMROTO platform is very good; it is very valuable for us from the development side when in-house developments are quickly and easily geometrically tested with the 3D simulation and then automatically ground on the machine with collision checks."



High feed milling cutter MD025 Supreme "Flash"

An example of this fusion of knowledge is the "Flash" high-feed milling cutter. The specific face sharpening and the double radius flutes are designed as external calculations, while the rest is according to the NUMROTO standard.

Technologically top-class is the new MD133 Supreme solid carbide milling cutter. As it follows a machining path on the milling machine with circular movements at high speed, a tooth geometry tailored to this is required. This can be achieved thanks to the optimum interaction of the programming systems.

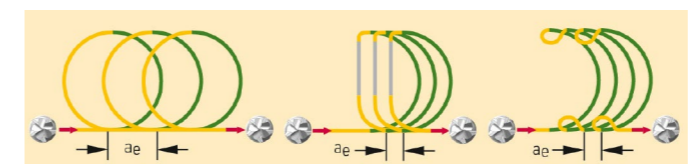

Differently coated solid carbide milling cutters of type MD133 Supreme for use in a wide range of applications. The tool family, which has been specially designed for the requirements of dynamic milling, is characterized by high chip volumes and at the same time enables large cutting depths

Fabian Lehmann, Team Leader Technology Development at Walter in Zell, Germany, says: "NUMROTO offers a cross-platform advantage through 'external calculation', which as far as we are aware is not available from any other provider." Martin Marx sees further advantages of NUMROTO in the quality of the implemented work: "Even if the development time sometimes takes a little longer than hoped for, there have never been problems with updates – they are always tested. In addition, existing functions are always upward compatible, even after many years."



Solid carbide milling cutter MD133 Supreme from Walter Prototyp in use



Examples of milling cutters with ConeFit replaceable head; they have been supplementing the product diversity at Walter Prototyp since 2009

Other services include the coating, marking, cleaning and surface treatment of tools. Walter's production site in Zell is certified according to DIN EN ISO 9001, 14001, 45001 and 50001. With its in-house Walter Academy, Walter AG also focuses on continuous professional qualification and further development of the personal skills of its employees.



From left to right: Mr. Fabian Lehmann (Teamleader Technology Development, Walter), Mr. Martin Marx (Software Developer TEWL, Walter), Mr. Jörg Federer (Manager Application Technology NUMROTO, NUM AG)

Complete CNC Solutions Worldwide



NUM systems and solutions are used worldwide.





Our global network of sales and service locations guarantees professional service from the beginning of a project to its execution and for the complete life cycle of the machine.

NUM has service centers around the world. Visit our website for the current list of locations.

www.num.com



Follow us on our social media channels for the latest information and news on NUM CNC applications.

-  [linkedin.com/company/num-ag](https://www.linkedin.com/company/num-ag)
-  WeChat-ID: NUM_CNC_CN
-  twitter.com/NUM_CNC
-  facebook.com/NUM.CNC.Applications